



Uniclass L7315 + L2123	EPIC J3413
Cl/SfB (52.5)	If9



Surface drainage for heavy duty traffic applications

ACO RoadDrain®

ACO RoadDrain®

CHANNEL DRAINS



Load Class (BS EN 1433:2002)

Optimum solution

ACO RoadDrain® is a one piece resin concrete drainage system which has been designed as the optimum solution for a wide range of surface drainage applications requiring Load Class D400 to F900 installations.

Lower costs

ACO RoadDrain® has been specifically designed to reduce installation time and provide inexpensive maintenance over its whole life.

It offers cost advantages to specifiers and contractors.

Open-minded innovation

ACO RoadDrain® is the result of the experience of innovative surface drainage solutions for highways, local authority, retail, commercial and domestic users.

Free technical support

To support the specifier and contractor in designing and installing ACO RoadDrain® schemes, ACO's Design Services Department offers computer-aided scheme design, hydraulic performance calculations and installation advice services.

Telephone Hotline:

01462 816666

Fax Hotline:

01462 851081

e-mail:

draintechnical@aco.co.uk

website:

www.aco.co.uk

Standards compliance

ACO RoadDrain® has been certificated to Load Class F900 (BS EN 1433:2002) and to BS EN 124:1994 for gully and access units.

ACO RoadDrain® complies with Specification for Highway Works Clause 517.

Contact ACO Technical Department for copies of standards details and Load Test certificates.

Benefits for specifiers

- ▶ **One piece design means no separate grating specifications**
- ▶ **Integral inlet grating in resin concrete cannot be lost or stolen**
- ▶ **Unique ACO registered inlet pattern mimics traditional cast iron gratings**
- ▶ **Resin concrete construction maintains colour and offers excellent chemical resistance**
- ▶ **Black as standard. Other colours available to order on request**
- ▶ **Quick scheme design using level invert units (see page 4)**
- ▶ **Sump and gully outlet connections to underground drainage**

Benefits for contractors

- ▶ **Strong, rigid one piece unit**
- ▶ **One piece unit means no components can be lost or stolen**
- ▶ **Rapid unit installation (see page 13-14 for installation details)**
- ▶ **No interlocking end joints for simple laying**
- ▶ **Easy to achieve excellent watertightness with sealing groove**
- ▶ **Light weight for easy handling**

Benefits for clients

- ▶ **One piece resin concrete construction is strong and rigid for lifetime integrity**
- ▶ **Integral unit eliminates lost or damaged gratings**
- ▶ **Flared inlet slot design minimises trapping of debris**
- ▶ **Access units and gullies for system maintenance**
- ▶ **Excellent frost resistance**





ACO RoadDrain®

CHANNEL DRAINS

Hydraulic choices with ACO

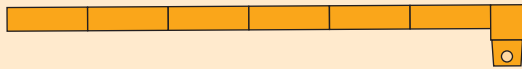

1. Constant Invert, Level Ground

- effective drainage but may need more regular maintenance due to greater chance of silting.

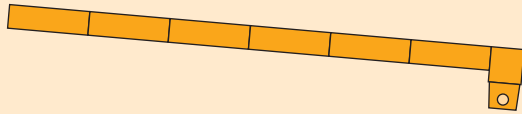

2. Constant Invert, Sloped Ground

- improved hydraulic capacity over system 1.

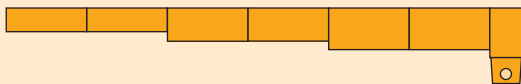

3. Stepped Invert, Level Ground

- will give a similar hydraulic capacity to system 2.

Note: For illustration only. See full parts listing on pages 6-12.

Resin concrete

- ▶ Minimal lifetime maintenance
- ▶ 3-4 times compressive strength of OPC (Ordinary Portland Cement), so products can be made lighter
- ▶ Water absorption <0.01% by weight*

Compressive Strength

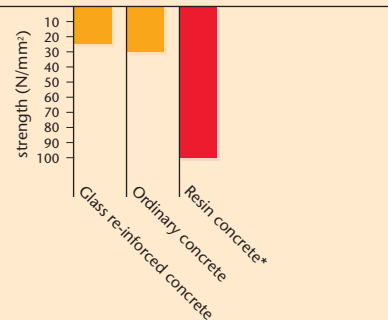

Water Absorption

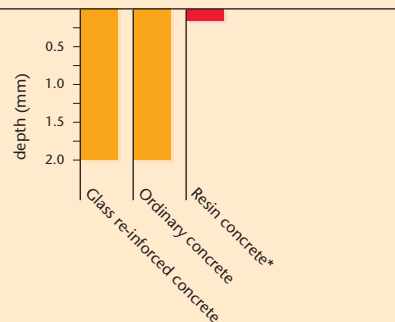

* BBA report No. 1580

ACO RoadDrain®

PD100 F CHANNEL RANGE LAYOUT

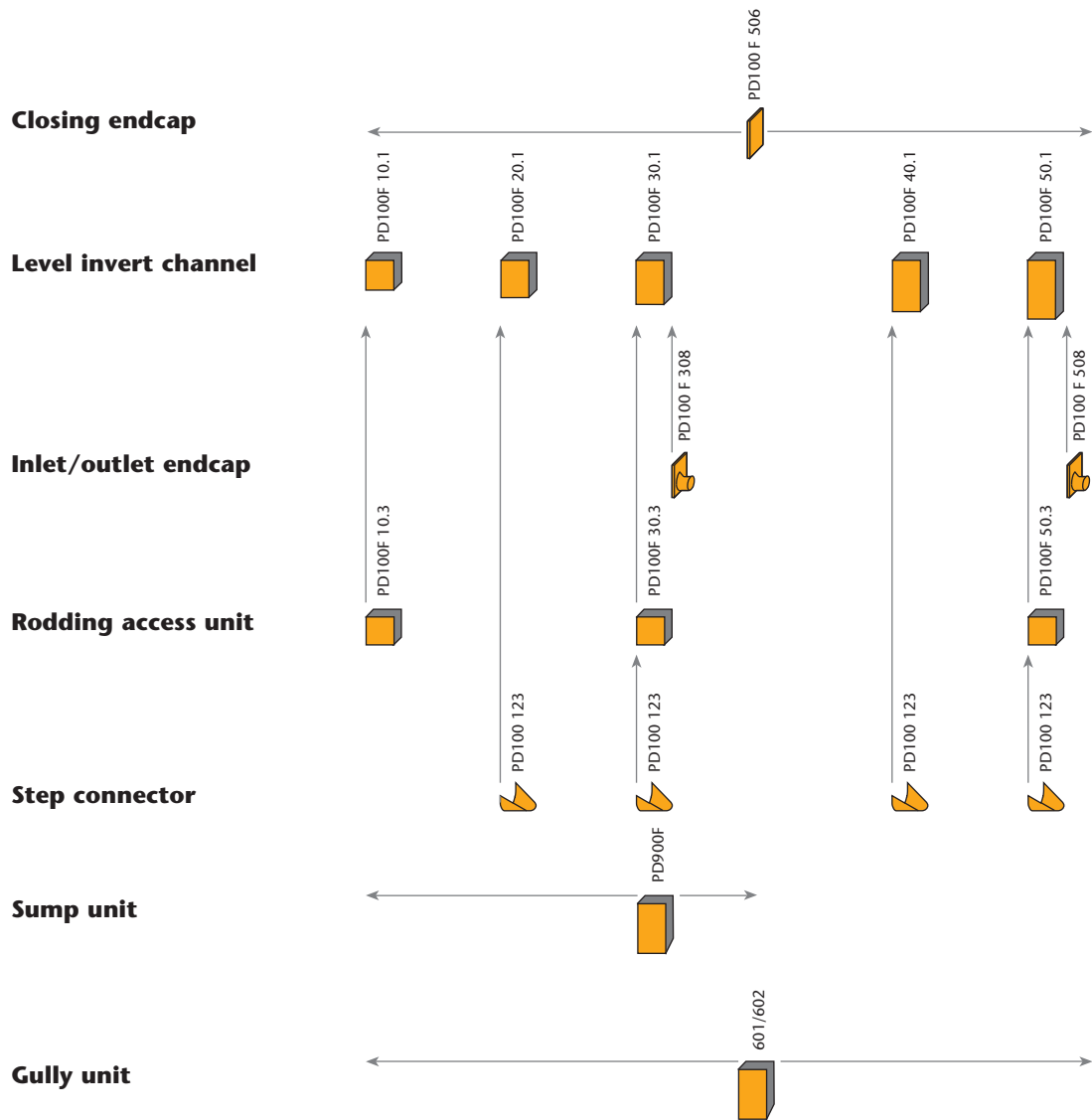



ACO RoadDrain®

PD200 F CHANNEL RANGE LAYOUT

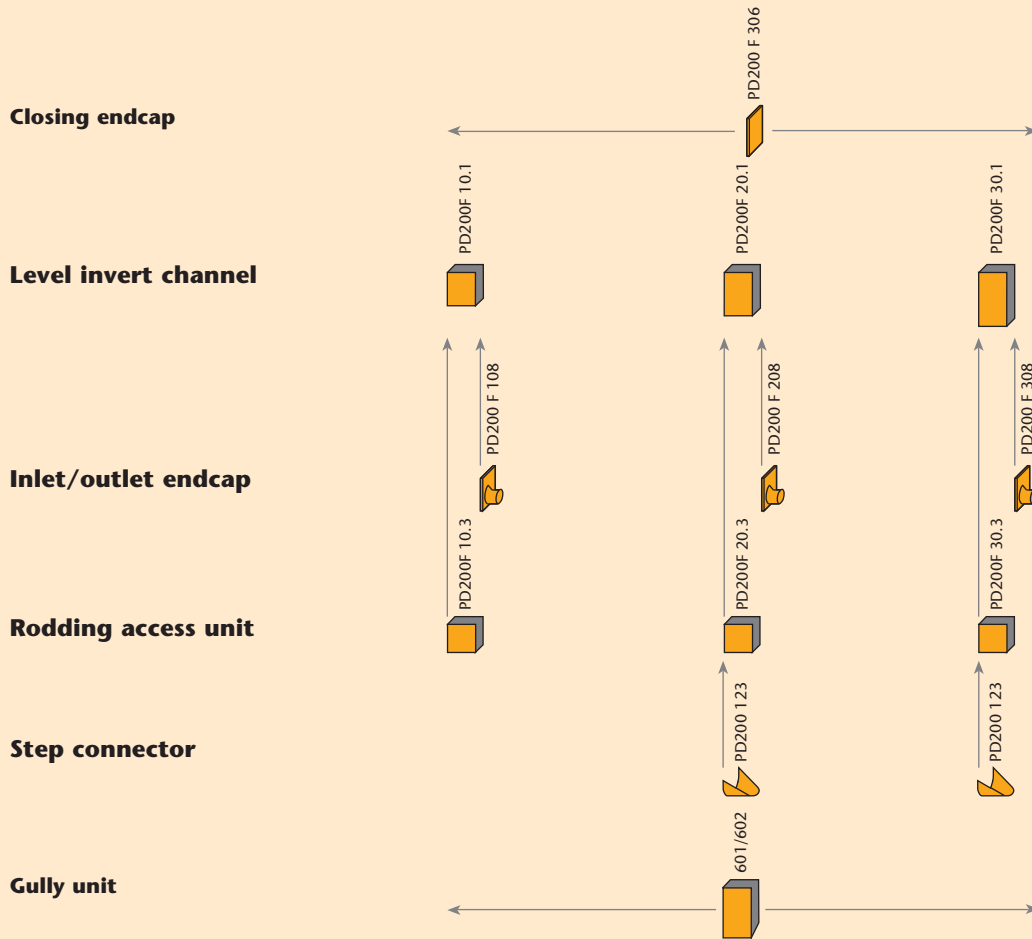

ACO RoadDrain®

HYDRAULIC PERFORMANCE TABLES

RoadDrain® 100 Hydraulics

PD100 F 10.1 Overall Depth = 250mm				
Length to outlet (m)	TOTAL Flow (l/s) Ground slope			
	0.0%	0.5%	1.0%	1.5%
5	5.8	7.0	8.0	8.9
10	5.5	7.5	9.0	10.1
15	5.2	7.7	9.5	10.7
20	5.0	7.9	9.8	11.2
25	4.8	8.1	10.1	11.6
30	4.6	8.2	10.3	12.0
40	4.3	8.4	10.7	12.6
60	3.9	8.6	11.0	13.6
80	3.5	8.6	11.3	14.2

PD100 F 20.1 Overall Depth = 300mm				
Length to outlet (m)	TOTAL Flow (l/s) Ground slope			
	0.0%	0.5%	1.0%	1.5%
5	9.8	11.4	12.7	14.0
10	9.2	11.7	13.8	15.4
15	8.7	12.0	14.4	16.5
20	8.3	12.1	14.9	17.2
25	8.0	12.2	15.2	17.6
30	7.6	12.3	15.5	18.1
40	7.3	12.6	15.9	18.6
60	6.7	12.8	16.5	19.4
80	6.1	13.1	16.7	19.8

PD100 F 30.1 Overall Depth = 350mm				
Length to outlet (m)	TOTAL Flow (l/s) Ground slope			
	0.0%	0.5%	1.0%	1.5%
5	14.5	16.5	18.4	19.9
10	13.9	16.9	19.3	21.4
15	13.2	17.3	20.0	22.5
20	12.6	17.5	20.6	23.3
25	12.1	17.7	21.1	23.7
30	11.6	17.8	21.3	24.1
40	10.9	17.8	21.8	24.7
60	9.9	17.8	22.5	25.6
80	9.2	17.9	22.9	26.4

PD100 F 40.1 Overall Depth = 400mm				
Length to outlet (m)	TOTAL Flow (l/s) Ground slope			
	0.0%	0.5%	1.0%	1.5%
5	20.1	22.7	24.5	26.3
10	18.8	22.8	25.2	28.0
15	18.0	22.9	25.9	29.4
20	17.1	23.0	26.5	30.3
25	16.3	23.1	27.1	30.9
30	15.5	23.1	27.6	31.5
40	14.7	23.1	28.1	32.0
60	13.4	23.1	28.5	32.6
80	12.5	23.2	28.8	33.3

PD100 F 50.1 Overall Depth = 450mm				
Length to outlet (m)	TOTAL Flow (l/s) Ground slope			
	0.0%	0.5%	1.0%	1.5%
5	26.1	28.4	31.4	33.2
10	24.4	28.4	32.1	34.9
15	23.3	28.4	32.7	35.8
20	22.2	28.4	33.3	36.7
25	21.4	28.4	33.8	37.3
30	20.6	28.4	34.3	37.8
40	19.3	28.4	34.9	38.6
60	17.4	28.3	35.4	39.7
80	16.2	28.2	35.7	40.5



RoadDrain® 200 Hydraulics

PD200 F 10.1 Overall Depth = 400mm				
Length to outlet (m)	TOTAL Flow (l/s) Ground slope			
	0.0%	0.5%	1.0%	1.5%
5	26.6	30.4	33.5	36.0
10	25.6	31.7	36.0	40.5
15	24.7	33.5	39.0	44.5
20	23.9	34.9	41.5	48.6
30	23.0	36.4	44.1	52.4
40	21.8	37.8	46.8	56.0
60	20.7	39.2	49.2	58.7
80	19.5	40.3	51.4	61.1
100	18.4	41.3	53.4	63.1
120	17.5	41.4	55.4	64.7
140	16.5	41.6	57.1	66.2
160	16.0	41.6	58.7	67.7
180	15.4	41.7	60.0	69.1
200	14.8	41.7	61.0	70.4

PD200 F 20.1 Overall Depth = 450mm				
Length to outlet (m)	TOTAL Flow (l/s) Ground slope			
	0.0%	0.5%	1.0%	1.5%
5	37.1	41.4	45.2	48.5
10	35.0	42.8	48.4	53.7
15	33.4	44.1	51.3	58.2
20	32.2	45.7	54.1	62.3
30	30.6	47.3	57.2	66.7
40	29.4	49.1	60.2	71.3
60	28.5	50.9	63.1	75.9
80	27.3	52.1	65.8	79.3
100	26.0	53.4	68.4	82.5
120	24.8	54.2	69.7	84.4
140	23.7	54.3	70.6	85.7
160	22.5	54.4	71.0	86.7
180	21.5	54.5	71.3	87.4
200	21.1	54.7	71.5	87.8

PD200 F 30.1 Overall Depth = 500mm				
Length to outlet (m)	TOTAL Flow (l/s) Ground slope			
	0.0%	0.5%	1.0%	1.5%
5	48.9	53.9	58.1	61.9
10	46.3	55.4	61.4	66.8
15	44.5	56.6	64.5	71.7
20	42.9	58.1	67.6	76.3
30	41.2	59.7	71.3	81.6
40	39.7	61.5	75.1	86.6
60	37.7	63.3	78.6	91.5
80	35.8	64.9	81.7	95.8
100	34.3	66.4	84.4	100.2
120	32.6	67.9	85.6	104.0
140	31.2	68.8	86.4	108.0
160	29.9	69.9	87.0	111.7
180	28.8	70.3	87.6	115.0
200	28.0	70.6	88.3	117.5



ACO RoadDrain® 100

PARTS TABLE

Channels

Description	Order no.	Dimensions (mm)					Weight (kg)	Connection Availability					
		Depth		Width		Length		Knockout		Gully Unit	Closing Endcap	Inlet/outlet Endcap	Step Connector
		Overall	Invert	Bore	Overall			Union	Sump				
PD100 F 10.1	32101	250	225	100	160	500	21.0	-	PD900 F	601/602/607	PD100 F 506	-	-
PD100 F 20.1	32201	300	275	100	160	500	23.5	-	PD900 F	601/602/607	PD100 F 506	-	PD100 F 123
PD100 F 30.1	32301	350	325	100	160	500	25.4	-	PD900 F	601/602/607	PD100 F 506	PD100 F 308	PD100 F 123
PD100 F 40.1	32401	400	375	100	160	500	27.5	-	-	601/602/607	PD100 F 506	-	PD100 F 123
PD100 F 50.1	32501	450	425	100	160	500	29.8	-	-	601/602/607	PD100 F 506	PD100 F 508	PD100 F 123

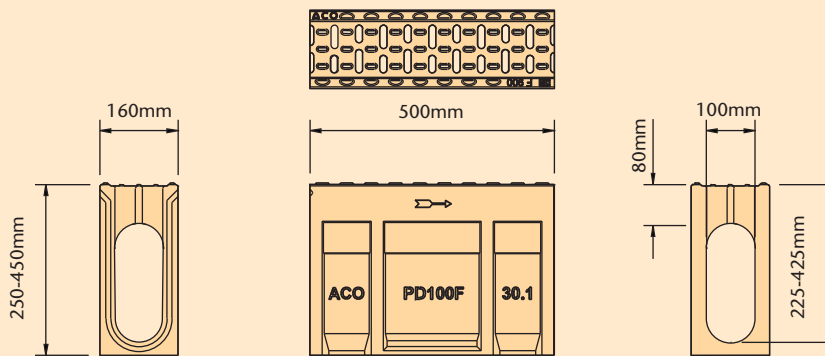

Rodding access

Description	Order no.	Dimensions (mm)					Weight (kg)	Connection Availability					
		Depth		Width		Length		Knockout		Gully Unit	Closing Endcap	Inlet/outlet Endcap	Step Connector
		Overall	Invert	Bore	Overall			Union	Sump				
PD100 F 10.3*	32103	250	225	100	160	500	26.4	820	PD900 F	601/602/607	PD100 F 506	-	-
PD100 F 30.3*	32303	350	325	100	160	500	31.0	820	PD900 F	601/602/607	PD100 F 506	PD100 F 308	PD100 F 123
PD100 F 50.3*	32503	450	425	100	160	500	34.6	820	-	601/602/607	PD100 F 506	PD100 F 508	PD100 F 123

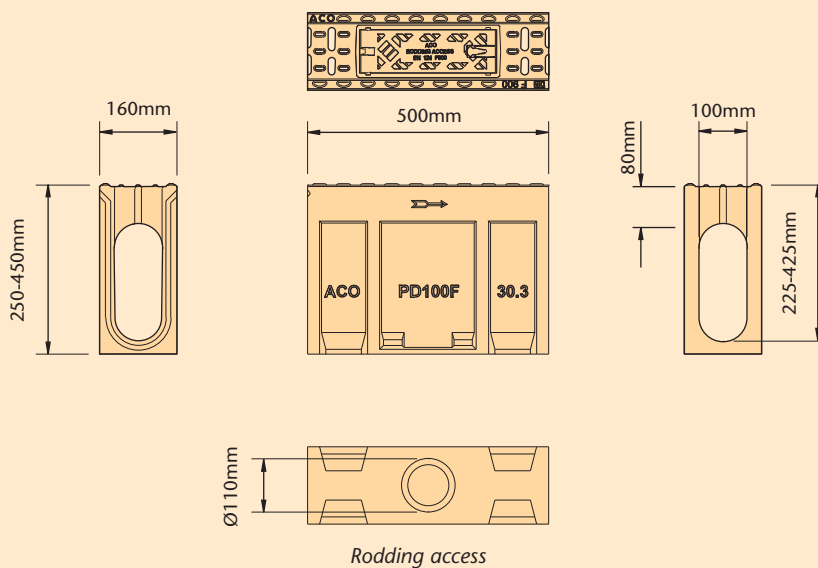

* These level invert channels have a preformed Ø110mm round knockout for vertical outlet.

Note: As with all pre-cast products, polymer concrete units are subject to dimensional and weight tolerances.

ACO RoadDrain® 100

PARTS TABLE

Endcaps closing and inlet/outlet

Description	Order no.	Dimensions (mm)					Weight (kg)
		Depth		Width			
		Overall	Invert	Bore	Overall	Length	
PD100 F 506 Closing endcap	32506	450	-	-	160	25	2.8
PD100 F 308 Inlet/outlet endcap	32308	350	325	150	160	25	2.2
PD100 F 508 Inlet/outlet endcap	32508	450	425	150	160	25	3.0

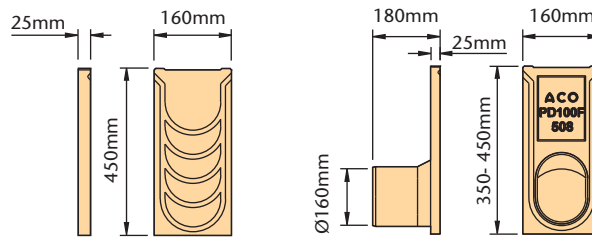

Discharge (l/s)
350mm 26.7
450mm 31.0

No PD100 F 506
Closing endcap

No PD100 F 308/508
Outlet endcap

Step connector

Description	Order no.	Dimensions (mm)					Weight (kg)
		Depth		Width			
		Overall	Invert	Bore	Overall	Length	
PD100 F 123 Step connector	30123	-	50	94	150	123	0.9

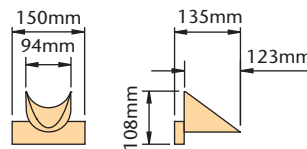

Step connector

Sump unit includes sediment bucket

Description	Order no.	Dimensions (mm)					Weight (kg)
		Depth		Width			
		Overall	Invert	Bore	Overall	Length	
PD900 F Sump includes sediment bucket	32900	665	640	100	160	500	43.6

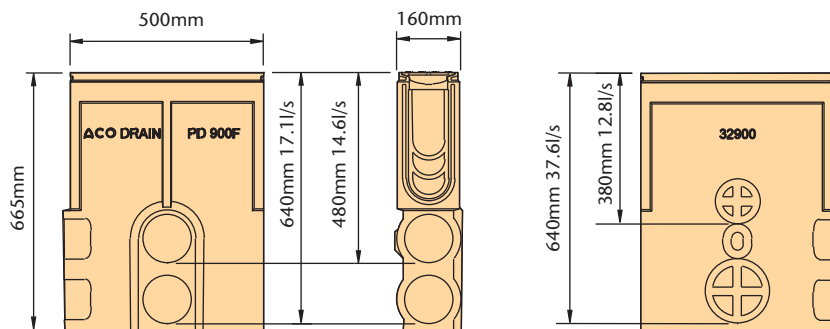

Sump unit



ACO RoadDrain® 100

PARTS TABLE

Foul air trap

Description	Order no.	Dimensions (mm)					Weight (kg)
		Depth		Width			
		Overall	Invert	Bore	Overall	Length	
920 Foul air trap PVC-U Ø110mm	2640	-	390	100	110	-	0.5
922 Foul air trap PVC-U Ø160mm	2638	-	375	150	160	-	1.9
940 Roddable foul air trap MDPE Ø110mm	7931	-	480	100	110	-	0.6
950 Roddable foul air trap MDPE Ø160mm	7932	-	435	150	160	-	0.8

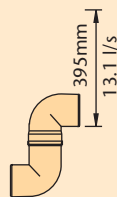

No 920
Foul air trap
PVC-U Ø110mm

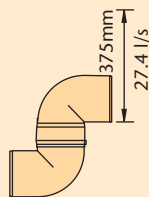

No 922
Foul air trap
PVC-U Ø160mm

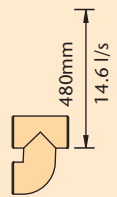

No 940
Roddable
foul air trap
MDPE Ø110mm

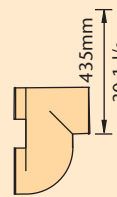

No 950
Roddable
foul air trap
MDPE Ø160mm

Drain unions

Description	Order no.	Dimensions (mm)					Weight (kg)
		Depth		Width			
		Overall	Invert	Bore	Overall	Length	
820 Drain union PVC-U Ø110mm	0056	-	-	100	110	100	0.1
822 Drain union PVC-U Ø160mm	0058	-	-	150	160	150	0.5



No 820
Drain union
PVC-U Ø110mm



No 822
Drain union
PVC-U Ø160mm

ACO RoadDrain® 200

PARTS TABLE

Channels

Description	Order no.	Dimensions						Weight (kg)	Connection Availability				
		Depth		Width			Knockout Union		Gully Unit	Closing Endcap	Inlet/outlet Endcap	Step Connector	
		Overall	Invert	Bore	Overall	Length							
PD200 F 10.1	33101	400	370	200	260	500	52.0	-	601/602/607	PD200 F 306	PD200 F 108	PD200 F 123	
PD200 F 20.1	33201	450	420	200	260	500	54.5	-	601/602/607	PD200 F 306	PD200 F 208	PD200 F 123	
PD200 F 30.1	33301	500	470	200	260	500	58.3	-	601/602/607	PD200 F 306	PD200 F 308	PD200 F 123	

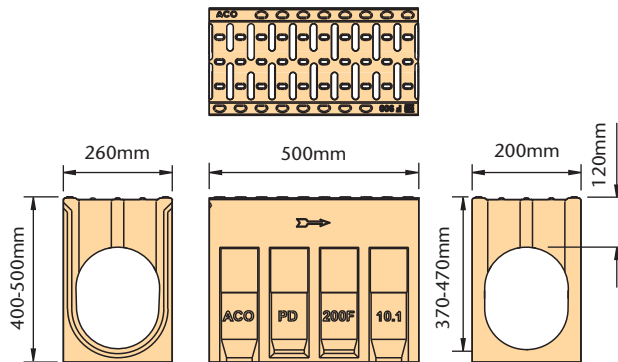

Rodding access

Description	Order no.	Dimensions						Weight (kg)	Connection Availability				
		Depth		Width			Knockout Union		Gully Unit	Closing Endcap	Inlet/outlet Endcap	Step Connector	
		Overall	Invert	Bore	Overall	Length							
PD200 F 10.3	33103	400	370	200	260	500	60.5	822	601/602/607	PD200 F 306	PD200 F 108	PD200 F 123	
PD200 F 20.3	33203	450	420	200	260	500	53.5	822	601/602/607	PD200 F 306	PD200 F 208	PD200 F 123	
PD200 F 30.3	33303	500	470	200	260	500	56.0	822	601/602/607	PD200 F 306	PD200 F 308	PD200 F 123	

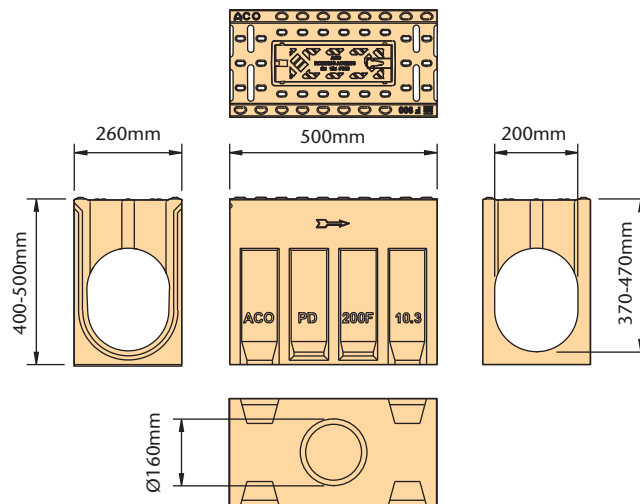

Rodding access





ACO RoadDrain® 200

PARTS TABLE

Endcaps closing and inlet/outlet

Description	Order no.	Dimensions (mm)					Weight (kg)
		Depth		Width			
		Overall	Invert	Bore	Overall	Length	
PD200 F 306 Closing endcap	33306	500	-	-	260	25	4.6
PD200 F 108 Inlet/outlet endcap	33108	400	375	150	260	25	4.3
PD200 F 208 Inlet/outlet endcap	33208	450	425	150	260	25	4.7
PD200 F 308 Inlet/outlet endcap	33308	500	475	150	260	25	5.2

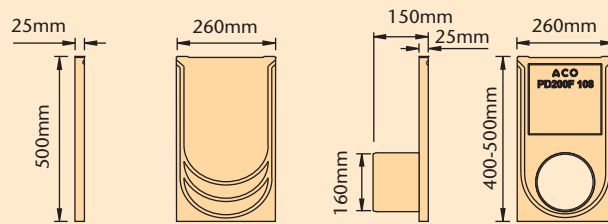

Discharge (l/s)
400mm 29.0
450mm 31.0
500mm 33.0

No 306
Closing endcap

No 108/208/308
Inlet/outlet endcap

Step connector

Description	Order no.	Dimensions (mm)					Weight (kg)
		Depth		Width			
		Overall	Invert	Bore	Overall	Length	
PD200 F 123 Step connector	33123	-	50	194	260	110	1.4

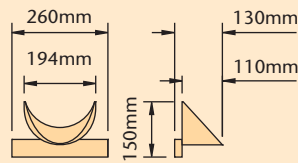

Step connector

Drain unions

Description	Order no.	Dimensions (mm)					Weight (kg)
		Depth		Width			
		Overall	Invert	Bore	Overall	Length	
822 Drain union PVC-U Ø160mm	0058	-	-	150	160	150	0.5



No 822
Drain union
PVC-U Ø160mm

Note: Standard Ø160mm knockout. As with all pre-cast products, the units are subject to dimensional tolerances. All weights are nominal. See installation recommendations pages 13 and 14.

ACO RoadDrain®

GULLY UNITS

Universal gully units

Description	Order no.	Dimensions (mm)			Weight (kg)
		Depth Overall***	Invert***	Width Clear opening	
601*	33601	1315	870	400 x 400	78.8
602**	33602	1315	870	400 x 400	77.4
607**	33607	650	-	400 x 400	73.1
615 connector	7060	40	-	Ø360	7.0

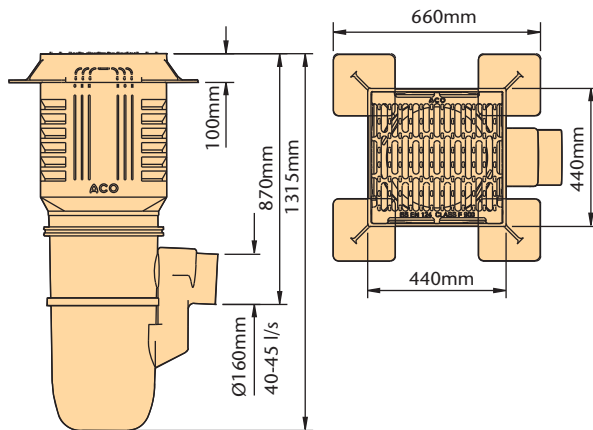

No 601 and No 602 Gully Assembly

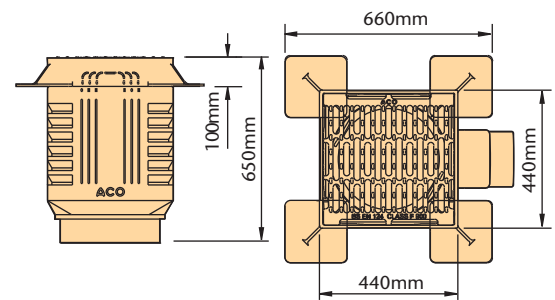

Top Unit Assembly No 607
Gully Pot supplied by others

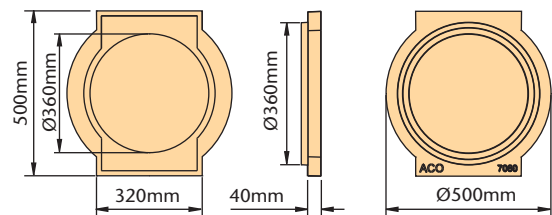

615 Connector



* with sediment bucket ** without sediment bucket *** minimum with no allowance for bedding.

Note: Plain PVC-U Ø150 - 160mm SuperSleeve adaptor supplied with assembly.

ACO RoadDrain®

SITWORK AND INSTALLATION

1.0 Ground Conditions

The customer should ensure that the minimum dimensions shown are suitable for the existing ground conditions. Engineering advice may be necessary.

2.0 Block Pavements

The channel must be supported laterally and therefore blocks must be restrained from movement by bedding securely e.g. by using a Polymer Modified Mortar for bed and perpendicular joints (for example RONAFIX Mortar Mix C from Ronacrete: Tel 01279 638700). Engineering advice may be required.

3.0 Surface Cracks

Alternate crack control and movement joints transversely within bed and haunch may reduce unsightly surface cracking.

4.0 Joint Sealant

Where ACO Drain channel joints and fittings are to be sealed (where used in foul water applications or where impermeability is required) contact a sealant specialist for guidance on the most appropriate sealing compound to use.

5.0 Surface Protection

In asphalt pavements avoid contact between compaction equipment and channel/grating. This may be achieved by ensuring that the finished surface level lies above the grating level (by at least 3mm). Stones should be removed from the grating prior to laying/rolling wearing course.

Asphalt Pavement

Note: Top of haunch 25mm maximum below wearing course

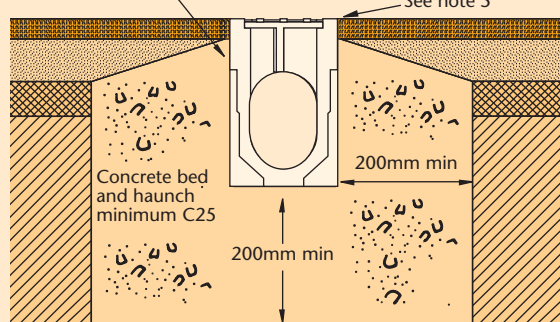

Concrete Pavement

Note: Expansion joint to engineers detail

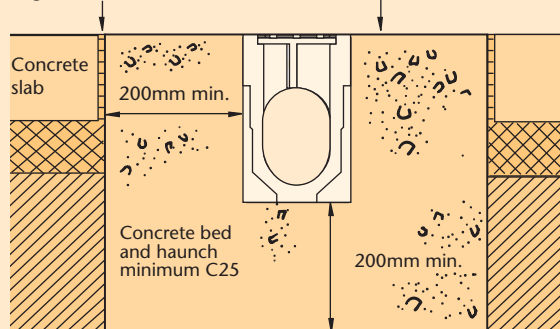

Block Pavement

Option 1 see note 3.0

See note 2.0

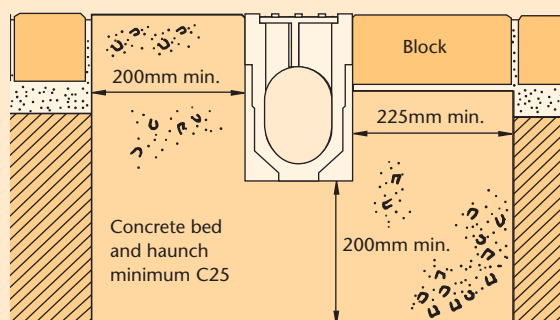

Dowel bar installation

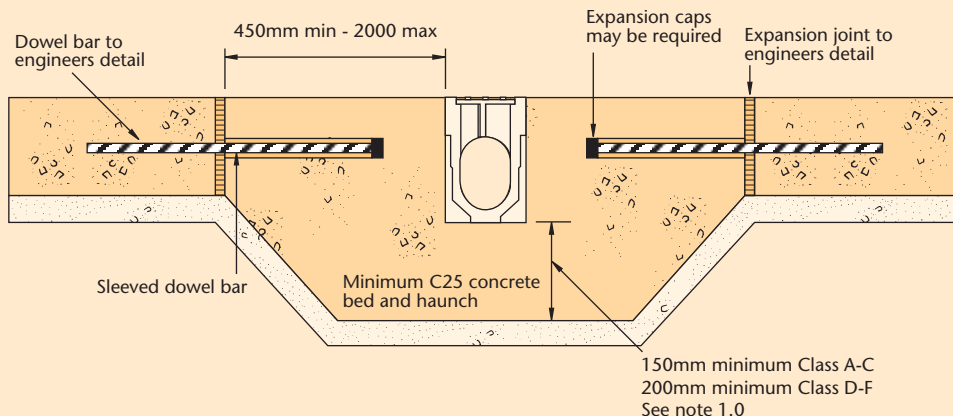

ACO Universal Gully

INSTALLATION DETAILS

Designed for ACO channel drainage systems up to 200mm internal width, the ACO Universal Gully comprises of a 3-piece modular system. Lightweight design for ease of handling and installation. The universal gully can accommodate channels on all four sides and is compatible with standard subsurface drainage systems to BS 4660. ACO Universal Gully has been certificated to BS EN 124:1994 Load Class F900.

Excavate a 150mm bed and surround (minimum 150mm Class A to C or minimum 300mm Class D to F), blind where necessary. Form concrete* bed for base unit 1 and set on mortar (or similar) levelling bed. Make pipe connections (PVC-U or SuperSleve) as appropriate.

Concrete* surround base unit 1 and pipes if required. Position gully intermediate unit 2 to level.

Concrete* bed for channels allowing levelling mortar bed if required. Extend concrete bed around unit 2. Install channels (see separate channel installation recommendations) with taped external joints at junction of unit 2 and end of channels.

Complete concrete* surround to unit 2 allowing for frame levelling bed. Cut out knockouts on gully frame 3 and cut profile of the channel from inside of unit 2. Install gully and haunch concrete* to the sides of channels as recommended in separate channel installation recommendations.

Descriptions

- 1 - Gully Base Unit. Polyethylene supplied by ACO or base by others
- 2 - Gully Intermediate Unit. Polyethylene
- 3 - Gully Top. Comprising of cast iron frame and grating.

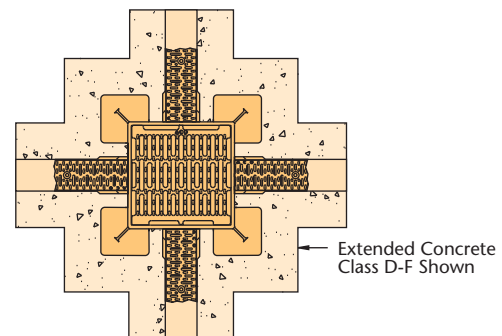
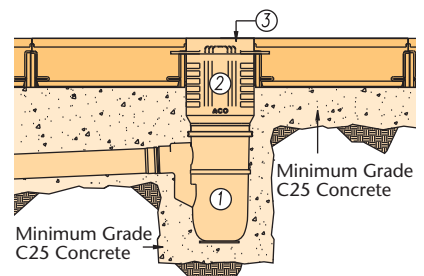
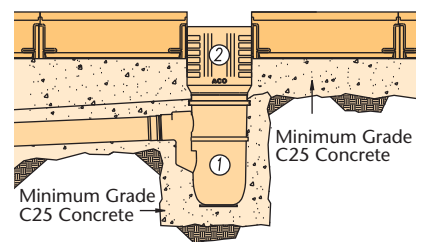
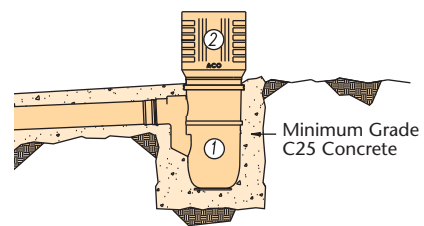



ACO RoadDrain®

SPECIFICATION CLAUSE

The surface drainage system shall be ACO RoadDrain® channels as supplied by ACO Technologies plc; all materials and components within the scope of this system shall be obtained from this manufacturer. The system shall be certified to BS EN 1433:2002 and BS EN 124 for the access and gully unit covers; load test certificates shall be supplied to the Supervising Officer. The system shall be of units 500mm long, 100 or 200mm nominal internal width, one piece manufacture in polyester resin concrete, with integral resin concrete grating featuring 15mm downward flared inlet slots to ACO registered pattern providing a minimum inlet area of 23260mm² per metre for ACO RoadDrain® 100 and 44260mm² per metre for ACO RoadDrain® 200.

The units shall be installed with all necessary, rodding access, gully and accessories as required for the scheme. The system shall be installed in accordance with the manufacturer's printed recommendations, and the work carried out as specified on the Supervising Officer's drawing no.* and in accordance with recognised good practice. Standards of workmanship shall generally be as specified in BS EN 752 and BS 8000:Part 14:1989.

* Please insert relevant drawing number(s)

Note: Also available on our website for downloading

Technical Support Services

To support architects, engineers and contractors in designing and installing ACO RoadDrain® schemes, ACO's Design Services Department offers computer-aided scheme design, hydraulic performance calculations and installation advice services.

Our Telephone Hotline 01462 816666, Fax Hotline 01462 851081, e-mail draintech@aco.co.uk and website www.aco.co.uk enable us to give you the response you need.



ACO Technologies plc

ACO Business Park,
Hitchin Road,
Shefford,
Bedfordshire
SG17 5TE

Tel: 01462 816666
Fax: 01462 815895

e-mail Sales: customersupport@aco.co.uk
e-mail Technical: draintechnical@aco.co.uk

website: www.aco.co.uk



© May 2008 ACO Technologies plc. All reasonable care has been taken in compiling the information in this document. All recommendations and suggestions on the use of ACO products are made without guarantee since the conditions of use are beyond the control of the Company. It is the customer's responsibility to ensure that each product is fit for its intended purpose, and that the actual conditions of use are suitable. This brochure and any advice is provided by ACO Technologies plc (the Company) free of charge and accordingly on terms that no liability including liability for negligence will attach to the Company or its servants or agents arising out of or in connection with or in relation to this brochure or any such advice. Any goods supplied by the Company will be supplied solely upon its standard conditions of sale, copies of which are available on request. The Company's policy of continuous product development and improvement renders specifications liable to modification. Information provided in this brochure is therefore subject to change without prior notification.

ACO CARES ABOUT THE ENVIRONMENT

Printed on material approved by the Pan European Forest Certification (PEFC) who provide a means of assuring that products come from sustainably managed forests.