



# Hospitals



are you in the **know?**

For more information on Knauf Drywall visit [www.barbourproductsearch.info](http://www.barbourproductsearch.info)

**KNAUF DRYWALL**

# HOSPITALS

## **Knauf Drywall systems – delivering solutions to meet customer needs**

Knauf is a family owned company with approximately 18,000 employees worldwide.

Founded originally in Germany in 1932, Knauf entered the UK market in 1988 and was rebranded Knauf Drywall in 2003.

With two major manufacturing sites in the UK, Knauf Drywall is one of the leading suppliers of gypsum based materials in the UK. The UK manufacturing facilities are set up to adapt quickly to changing requirements and to offer maximum flexibility to suit specific needs. All production has the assurance of quality to BS EN ISO 9001: 2000.



<b>Introduction and services</b>	<b>3</b>
<b>System application selection</b>	<b>4-5</b>
<b>Design considerations</b>	
Acoustic	6-8
Protection	9
Fire	10-11
Finishes	12-13
Fixings	14-15
Robustness	16
<b>Specification tips</b>	<b>17</b>
<b>Design solutions</b>	
Partitions	18-19
Shaftwall	20
Bespoke hospital solutions	21
Ceilings	22
<b>Best practice detailing</b>	<b>23-27</b>
<b>Project profiles</b>	<b>28-31</b>

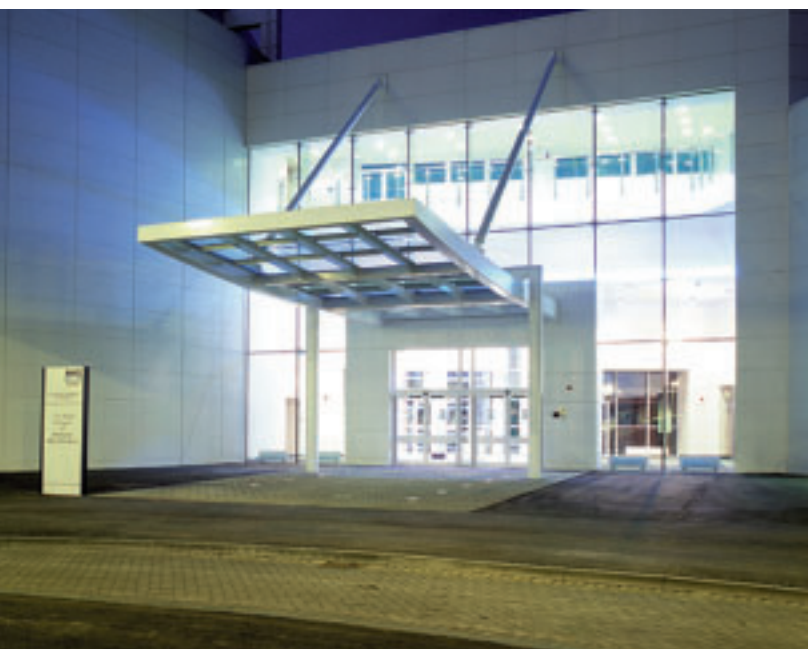

## Hospital expertise

From initial concepts of hospital specifications through to creating bespoke installation solutions on-site, Knauf Drywall has the expertise and experience you can rely on, with over 30 major hospital projects completed in the past 3 years.

On large developments, our Project and Specification Managers are on hand to guide and assist, visiting site as necessary throughout the duration of the project. With additional support from our dedicated technical helpline, you are guaranteed a rapid response to help solve any problems you may encounter.

This guide offers advice on the various design considerations and technical requirements specific to hospitals, and offers a number of optimised proposals for drywall design solutions. It is, however, merely a taste of the whole service which Knauf Drywall can offer.\*

## Service

At Knauf Drywall we understand and deliver the high level of service that our customers need and expect. Our flexible approach means that we do whatever we can to help, working within the framework of our customer's business.

Whatever the size or nature of the project, a professional member of the Knauf Drywall team can always help.

## Technical excellence

We are committed to continually providing superior, innovative technical solutions, not only with our products but with revolutionary support tools for our customers.

## Quality

We take pride in the products and service we provide and recognise that the measure of quality will always be judged through the eyes of our customers. To this end, Knauf Drywall is committed to continually improving not only its products but also the performance of the business.

\* The Complete Drywall Manual provides comprehensive information on all our products and systems, including non-sector specific details not included in this brochure. It can also be accessed online at our award winning website:

[www.knaufdrywall.co.uk/themanual](http://www.knaufdrywall.co.uk/themanual)



# HOSPITALS

## SYSTEM APPLICATION SELECTION

Knauf Drywall recognises that each part of a new hospital holds unique challenges, such as mixtures of high acoustic and impact performance, the use of special finishes and lead lining, and a diverse range of fixing requirements.

To help you navigate this guide, the individual construction elements of a typical hospital and the appropriate page references for information relevant to them are detailed below and opposite.

### Canteens

Design solutions: Partitions  
pages 18-19

### X-ray suites

Bespoke hospital solutions  
page 21

### Services penetrations

Best practice detailing  
page 26

### Accident and emergency

Design solutions: Ceilings  
page 22

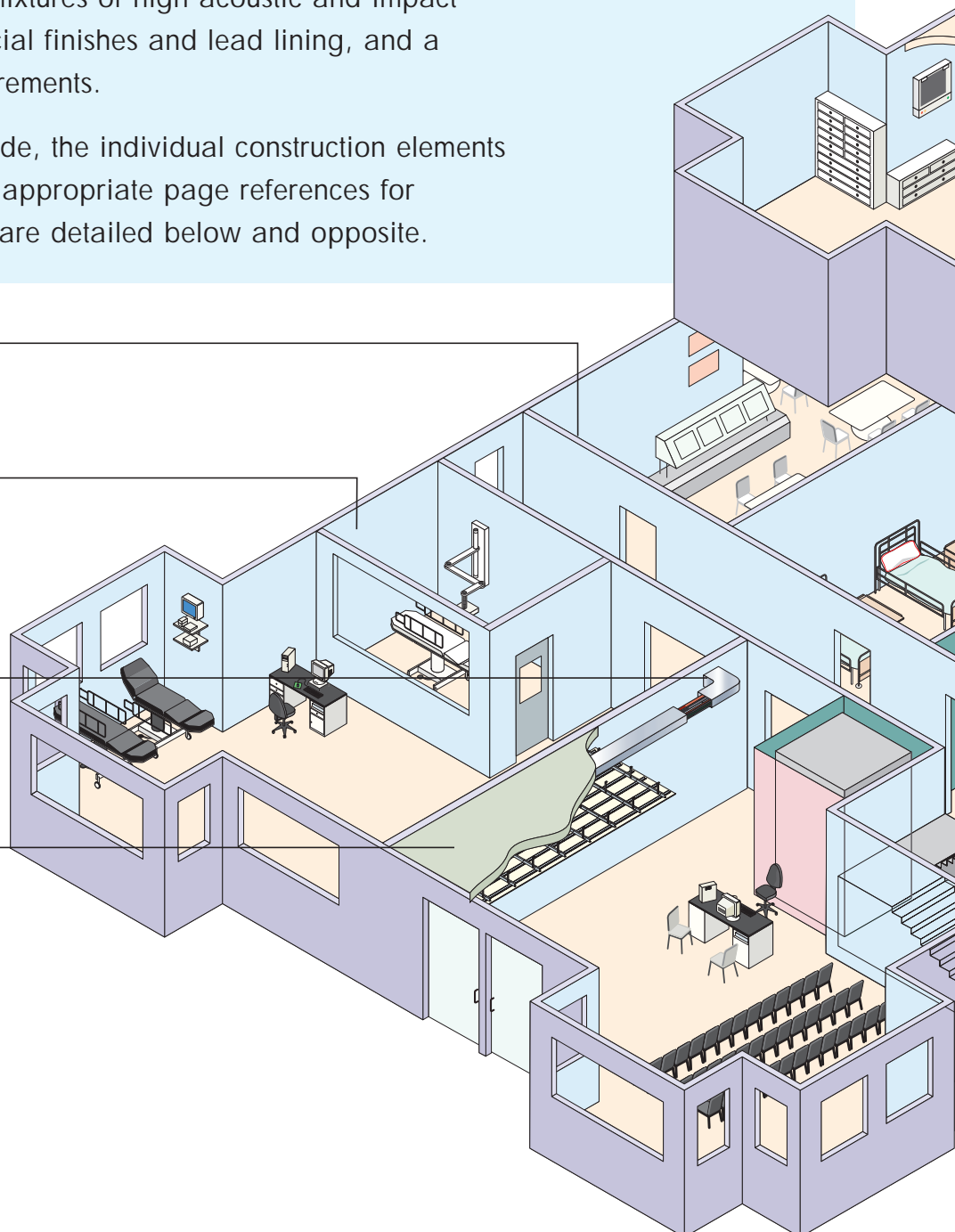

**Doors (jamb and lintels)**

Best practice detailing  
pages 23-24

**Examination rooms**

Design solutions: Partitions  
pages 18-19

**Doors (jamb and lintels)**

Best practice detailing  
pages 23-24

**Services penetrations**

Best practice detailing  
page 26

**Structure and fixings**

Best practice detailing  
page 25

**Structure and fixings**

Best practice detailing  
page 25

**Lift shafts**

Design solutions: Shaftwall  
page 20

**Multi-bed wards**

Design solutions: Partitions  
pages 18-19

**A & E treatment rooms**

Design solutions: Ceilings  
page 22

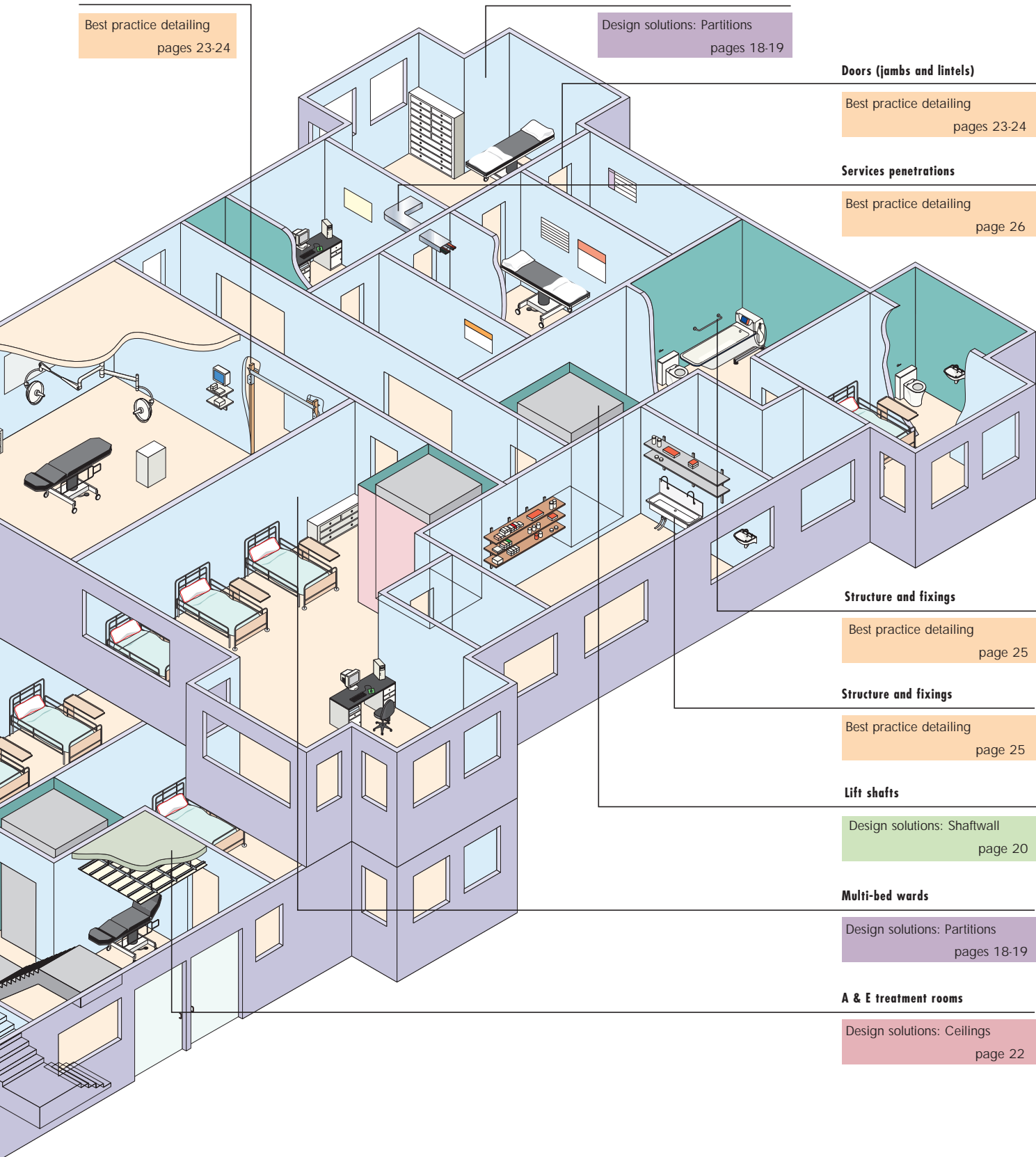

# HOSPITALS

## DESIGN CONSIDERATIONS

The following pages set out some of the construction and design issues that must be addressed when using Knauf Drywall products and systems for hospital projects.

We have referred extensively to the appropriate Building Regulations and Health Technical Memorandums but, due to limitations of space, have condensed their content to try to show information relevant to the specifiers and designers using this document.

In practice, the Building Regulations and Health Technical Memorandums should be referred to as definitive guidance.



## ACOUSTIC CONSIDERATIONS

### Relevant documents

Health Technical Memorandum (HTM) 56: Partitions (especially Section 2.4: Sound reduction).

HTM 2045 Acoustics: This Memorandum is split into four parts: 'Design Considerations' and 'Audiology' are covered in this document.

Note: HTM 2045 will eventually supersede the acoustic requirements of HTM 56, but at present either document may be used. This brochure refers to both documents.

HTM 57: Internal glazing (Section 2.10 Sound insulation).

HTM 58: Internal doorsets (Section 2.10 Sound insulation).

HTM 60: Ceilings (Section 3.9 Sound absorption).

BS 2750: 1980 (1993) Measurement of sound insulation in buildings and of building elements.

BS 5363: 1976 (1993) Method for measurement of reverberation time in auditoria.

BS 5821: 1984 (1993) Methods for rating the sound insulation in buildings and of building elements.

ISO 8233 Acoustics: Audiometric test methods.

### Objectives of regulations

HTM 2045 'Design considerations' sets out the overall requirements and considerations that should be given to noise control in healthcare premises.

HTM 2045 'Audiology' is concerned solely with audiology facilities.

In order to ensure that hearing tests can be carried out properly, the acoustics of audiological departments require careful consideration. Background noise levels must always be carefully controlled.

HTM 56 sets out minimum levels of acoustic separation for different groups of hospital spaces (see overleaf).

HTM 56 also quotes typical background noise levels, and provides a table of the typical sound reduction performance of hollow plasterboard partitions.

HTM 57 gives advice on balancing the need for internal glazing against the reduction in sound insulation.

HTM 58 gives advice on the sound insulation achieved by doorsets.

HTM 60 gives guidance on the sound absorption qualities of typical ceilings.

### HTM 56 'Partitions'

HTM 56 offers guidance on the design and specification of partitions which will meet the general requirements of users and conditions of use in health buildings.

Table 1, right, covers most of the common activity spaces within a typical hospital. The table grades non-loadbearing partitions according to their ability to provide minimum levels of airborne sound insulation for certain areas of activity. For these, and other areas, a number of possible solutions are available subject to project requirements.

The higher the level of background noise in a room, the lower the sound reduction value must be to maintain speech privacy (approx. 40dB).

Some of the key considerations to maintain sound insulation performance are:

- the adequate sealing of perimeter junctions at interfaces with other elements and around penetrations.
- the performance characteristics of doors/internal glazing in comparison to that of the partition (section 2.10 HTM 57). A well-fitting door of solid core construction for instance, will achieve a sound insulation of 15-20 dB (section 2.10 HTM 58).
- the fitting of sound attenuators within ducts at the point where the partition is penetrated.

- for suspended ceilings, the average sound co-efficient of the four middle frequencies (the Noise Reduction Co-efficient, or NRC) is the critical factor. A value of not less than 0.5 is recognised as having significance (section 3.9 HTM 60).

The Knauf Drywall Project Specification Team can help calculate  $R_w$  for a wide variety of applications. Knauf Drywall recommended construction solutions (with  $R_w$  ratings) to suit the applications covered in Table 1, can be found on page 19.

**Table 1 – Airborne sound insulation requirements (HTM 56)**

Location	Consulting rooms	Examination rooms	Treatment rooms	Speech therapy rooms	Offices	Seminar rooms	Single-bed wards	Multi-bed wards	Day rooms	Nurseries	Toilets and bathrooms	Utility rooms	Ward pantries	Plant motor rooms
Consulting rooms	43	43	*	48	43	48	43	53	53	*	48	*	48	*
Examination rooms	43	43	53	48	43	43	43	53	53	*	48	*	48	*
Treatment rooms	*	53	43	*	53	48	*	48	43	43	48	43	48	*
Speech therapy rooms	48	48	*	48	48	53	48	*	*	*	53	*	53	*
Offices	43	43	53	48	48	43	43	48	48	53	43	53	43	*
Seminar rooms	48	43	48	53	43	38	48	43	43	48	43	48	38	*
Single-bed wards	43	43	*	48	43	48	43	53	53	*	48	*	48	*
Multi-bed wards	53	53	48	*	48	43	53	43	43	48	48	48	43	*
Day rooms	53	53	43	*	48	43	53	43	48	43	48	43	48	*
Nurseries	*	*	43	*	53	48	*	48	43	43	48	43	48	*
Toilets and bathrooms	48	48	48	53	43	43	48	48	48	48	43	48	43	*
Utility rooms	*	*	43	*	53	48	*	48	43	43	48	43	48	*
Ward pantries	48	48	48	53	43	38	48	43	43	48	43	48	38	*
Plant motor rooms	*	*	*	*	*	*	*	*	*	*	*	*	*	*

**Notes to Table 1:**

Partitions between adjacent spaces marked \* in this table should, if possible, be designed out, because the satisfactory sound insulation of partitions between them may require special construction.

In the case of Plant Rooms, there is no specified requirement, and each situation needs separate consideration by the designer.

The minimum airborne weighted sound reduction index requirements are taken from BS 5821: Parts 2 & 3.

**HTM 2045 ‘Design considerations’**

HTM 2045 ‘Design considerations’ is concerned with the control, reduction and absorption of noise (and vibration) in hospitals, excepting audiology facilities (see HTM 2045 Audiology facilities, page 8).

The general principles of HTM 2045 ‘Design Considerations’ are that:

- interior environments must be protected from external noise sources.
- noise from interior areas should not adversely intrude on other interior areas, especially communications areas.
- internally generated noise should not adversely affect the external environment.

**The causes of ‘noise’**

Mechanical services noise: this includes noise from all service installations, duct borne fan noise, noise from equipment, noise from roof-mounted plant.

Intrusive noise: a term used for noise reaching a given area from all sources other than mechanical services noise, for instance traffic noise, aircraft noise etc.

Both ‘mechanical services’ noise and ‘intrusive noise’ criteria are specified by a Noise Rating (NR) value (see Table 2, below).

**Using internal partitions to create sound insulation**

For ‘noise critical’ internal areas, the following rules are applied:

- obtain noise data from surveys/predictive calculations.
- design partition to achieve appropriate NR value for area in question based on predicted noise levels. Calculate performance in terms of weighted apparent sound reduction index (BS 5821: Part 1) (see overleaf).

**Privacy Factor**

An important factor in calculating the airborne sound insulation performance requirements for internal partitions is ‘privacy’. This is the extent to which conversation and activities in one area are audible in an adjacent area.

The Privacy Factor is subject to:

- the subjective privacy requirement for the area(s) under consideration.
- the mechanical services noise levels for the area(s) under consideration.

(continues overleaf)

**Table 2 – NR values <sup>1</sup>**

Location	Recommended NR level for mechanical services noise	Recommended NR level for intrusive noise
Operating theatre, single bed ward	30	35
Private office, meeting and consultation room	30	35
Lecture theatre	30	35
Multi-bed ward, waiting room	30	40
Staff room, recreation room, cafeteria	35	45
General office	35	40
Corridor, laboratory	40	50
Washroom, toilet, kitchen	45	50

**Notes to Table 2:**

<sup>1</sup> NR values are given as equivalent continuous sound pressure level (Leq) for ‘worst case’ or highest noise level scenarios. When an area is not listed above, base values on the most similar location.

# HOSPITALS

## ACOUSTIC CONSIDERATIONS

### Privacy Factor (continued)

The Privacy Factor (PF) is defined as:  
 $PF = R'_w + B$

where:

$R'_w$  is the site-tested weighted apparent sound reduction index of the partition.

B is the mechanical services noise criterion in terms of Noise Reduction (NR) noise (mechanical services and intrusive, as defined on page 7).

The Knauf Drywall Project Specification Team can help calculate  $R'_w$  for a wide variety of applications. We recommend that, when specifying a partition to achieve a calculated  $R'_w$  factor using HTM 2045 methodology, a figure of 7dB should be added to the calculated  $R'_w$  factor and the relevant Knauf Drywall partition chosen on the basis of this, higher figure.

We always recommend confirming the 7dB figure with the project acoustician.

For dividing rooms with different PF's, the higher PF should be used to dictate the performance requirements of the partition.

### Worked example

A waiting room with a subjective PF requirement of 'clearly audible and intelligible.'

$PF = 70$  (see table 3)

B (mechanical services noise criteria) = NR30 (see table 2, page 7)

$R'_w$  for partitions enclosing the waiting room is:

$R'_w = PF - B$ , so  $R'_w = 70 - 30 = 40\text{dB}$

We would recommend specifying a Knauf Drywall partition of:

$40 + 7 = 47\text{ dB performance}$

Note that there is a correction factor, 'C', allowing for differing voice levels in different rooms as follows:

Voice effort	Voice effort correction factor
Raised	5
Shout	10
Scream	20

C is added to B to define  $R'_w$ . So for a waiting room adjacent to a room from which shouts may be heard

$R'_w = PF - B + C$

$R'_w = 70 - 30 + 10 = 50\text{dB}$

### Sound insulation testing

Those building elements for which airborne and impact sound insulation criteria have been established should be tested in accordance with parts 1-9 of BS 2750, 'Measurement of sound insulation in buildings and of building elements'.

### Reverberation times

Reverberation Time (RT) measurements should be carried out in those areas that have been assigned RT design criteria. It may be sufficient to carry out a single test for a group of similar rooms. Reference should be made to BS 5363. This standard applies to auditoria, but the principles remain the same, whatever the application.

Reverberation Times can be effectively controlled by the use of proprietary systems such as Knauf Apertura.

Internal surface finishes should be chosen to achieve the appropriate Reverberation Time (RT) for the given area. The project acoustician will normally advise on choice of finish to achieve specific criteria.

### HTM 2045 'Audiology'

Audiology facilities make use of the designed acoustics of their rooms and booths to enhance their functionality. The control of background noise levels is

**Table 3 – General ambient noise level criteria for non-critical areas**

Privacy Factor (PF)	Resulting privacy assuming normal speech
< 70	Clearly audible and intelligible
70-75	Audible but not intrusive
75-80	Audible but not intelligible
>80	Inaudible

**Table 4 – Recommended Privacy Factors assuming normal speech effort**

Location	Recommended Privacy Factor
Audiology facilities; fitting room; observation room	80
Maternity; nursery; Accident & Emergency <sup>1</sup>	80
Operating theatre; single-bed ward; multi-bed ward; private office; Meeting and consultation rooms; lecture theatre	80
Laboratory; staff room; general office	75
Waiting room; corridor; washroom; toilet; kitchen; recreation room; cafeteria	70

**Notes to Table 4:**

1 These rooms are identified as areas which are likely to be a source of shouts or screams. To allow for this, a 'voice effort correction factor' of 20 dB should be added to the PF of any adjacent room.

more critical in these areas and, although many of the above general HTM 2045 'Design Considerations' criteria and methodologies apply, it is essential to consult with acoustics experts at an early stage in the design process.

### Audiology facilities

The degree of airborne sound insulation provided by a facade dictates how much noise from the external environment breaks into a building. This intrusive external noise, when combined with noise from other sources, such as mechanical services, should not exceed the recommended levels for ambient noise given in HTM 2045.

The intrusive noise criterion should be used in conjunction with the external noise data to calculate the facade performance requirement in accordance with BS 5821: Part 3.

It is advisable to avoid external windows in audiometric test facilities, as glazing does not normally provide adequate sound insulation.

### Background noise in critical areas

HTM 2045 sets out a procedure for carrying out noise level measurements during the commissioning process in critical areas, which should generally be carried out by a consultant.

**Types of protection according to category of damage risk (HTM 69: Protection)**

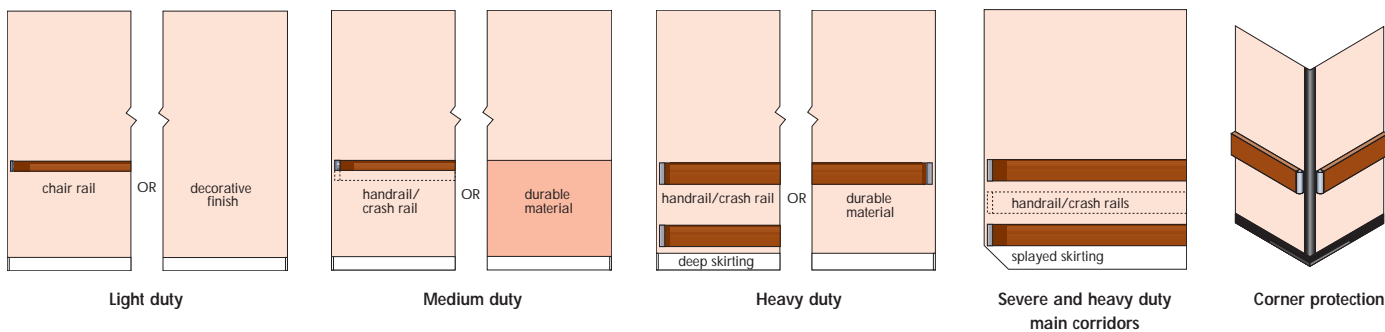

# PROTECTION

## Relevant documents

Health Technical Memorandum (HTM) 69: Protection, BS 5234: Partitions (including matching linings) Part 2: 1992: Specification for performance requirements for strength and robustness, including methods of test.

## Objectives of regulations

HTM 69 contains guidance for the use of design teams (such as Knauf Drywall Technical Services) and other specifiers on the avoidance or reduction of damage in health buildings.

## Categories of performance relating to damage risk and protection

HTM 69 lists four categories of performance relating to damage risk and protection, as a means of relating user requirements to construction and finishes. These categories are as follows:

**LD – Light duty** – Areas used by pedestrians, with occasional light, hand-propelled trolleys. Walls are unlikely to be damaged by mobile equipment. Rooms rather than circulation areas.

**MD – Medium duty** – Areas subject to occasional damage from patient beds, wheelchairs, light hand-propelled trolleys, light mobile medical equipment, chairs on castors etc. Rooms, lightly trafficked corridors etc.

**HD – Heavy duty** – Areas subject to regular damage from patient beds, wheelchairs, food or body trolleys, heavy mobile medical equipment. Clinical/nursing areas, treatment rooms, staff bases and corridors.

**SD – Severe duty** – Areas subject to regular damage from heavily laden hand-propelled trolleys, mechanically propelled tugs and trolleys. Hospital streets, circulation areas, entrances, delivery and working areas, stores and kitchen areas.

Suffix – (v) – Areas designated thus may be subject to vandalism. Public toilets etc., Accident and Emergency areas. Vandal-proof fittings and finishes normally required.

Knauf Drywall Technical Services can advise on the suitability of different protection types to meet the individual categories.

## Type of protection according to category of damage risk

The type of protection needed for walls will vary according to whether the location is in a room or a corridor. Damage is normally more severe in corridors because of the greater movement of mobile equipment.

**LD** – No additional protection required, select decorative finish according to durability and use of room. Chair rails may be required in committee rooms etc.

**MD** – Mid-height buffer rail and/or durable finish on middle or lower part of wall, bed locators in bedrooms.

**HD** – Mid-height handrail or crash rail and either durable material on lower part of walls, or lower height crash rail, and with splayed skirtings in main corridors.

**SD** – Mid-height handrail or crash rail, lower height crash rail and splayed skirtings.

Corridors designated as categories MD, HD and SD require some form of corner protection, according to vehicles expected. External angles in large rooms may also require corner protection.

In some areas, such as operating theatres, considerations of hygiene may take precedence over the protection recommended for areas where beds and trolleys are present. Rails may be omitted in favour of overall durable, washable finishes.

## Schedule of categories of finishes for walls, ceilings and floors and damage risk/protection

A schedule of categories of performance relating to damage risk and protection for individual activity spaces is provided in the Appendix to HTM 69, together with categories of performance of finishes, as given in HTM 56. These should be used to identify performance requirements.

## Guidance on selection of components

BS 5234 includes a separate test for crowd pressure in addition to the usual hard body impact tests. This provides useful information on the performance of partitions against the heavy impacts of electric tugs. Partitions designed and constructed in accordance with the relevant recommendations of BS 5234 should be able to withstand the dynamic loads imposed on them by impacts from heavy tugs and trolleys.

In areas where damage is expected, Knauf Drywall partitions can be specified with additional layers of plasterboard, including impact-resistant Knauf Denseshield. In addition, heavier gauge Knauf ‘C’ studs or Knauf ‘I’ studs may be specified for areas of ‘Severe’ duty. Fixings at head and floor must allow for the impact forces expected, (see HTM 70).

It will normally be necessary for the corners of drywall partitions to be protected.

## Protective devices

HTM 69 gives descriptions and dimensions for the following protective devices:

- handrails
- crash rails
- buffer rails
- chair rails
- corner guards
- large splayed skirtings
- protective plates and sheeting

HTM 69 also gives dimensions of typical mobile equipment to assist designers in positioning protective devices.

Energy-absorbing devices should be fitted wherever possible, especially where heavy impacts are expected.

Severe duty areas in health buildings are similar to circulation areas in airports and railway stations and should be protected by similar devices, such as crash rails, rubber or plastic buffer rails and large splayed skirtings or kerbs. If splayed skirtings or kerbs are not sufficient to prevent overhanging parts of trolleys or tugs from striking wall surfaces, then crash or buffer rails should be fitted.

The materials used should not be prone to splinter or produce sharp snags. Wood or medium-density fibreboard-based rails faced with high-impact plastics, sometimes with hardwood top and bottom edges, have proved satisfactory for handrails and crash rails.

Knauf Drywall Technical Services recommend the use of protective devices as indicated above to minimise the potential for damage to plasterboard systems within the building.

# HOSPITALS



## FIRE CONSIDERATIONS

### Relevant documents

Health Technical Memorandum (HTM) 56: Partitions (especially Section 2.5: Fire precautions).

Firecode HTM 81: Fire precautions in new hospitals.

HTM 57: Internal glazing (Section 2.9 Fire precautions).

HTM 58: Internal doorsets (Section 2.8 Fire precautions; Section 2.9 Smoke containment).

HTM 60: Ceilings (Section 3.8 fire resistance of suspended ceiling systems).

Building Regulations 2000: Approved Document B, Fire Safety: 2000 (2002).

### Objectives of regulations

HTM 56 provides a list of notes to assist the building designer in meeting the fire precaution requirements of the Building Regulations and the Firecode. It also includes paragraphs on cavity barriers, smoke control and surface spread of flame.

The main purpose of Firecode HTM 81 is to provide guidance on the standards of fire safety expected in new NHS hospitals. As fire safety is dependent not only on the physical fire precautions provided, HTM 81 also considers the fire safety implications of:

- the dependency of the patient

- fire hazards within the hospital

- management policies

- availability of sufficient and adequately trained staff.

Where the guidance given in Firecode HTM 81 is followed, The Building Regulations Part B will be satisfied.

HTM 60 sets out the preferred relationship of ceilings to partitions and walls, i.e. that partitions and walls should pass through suspended ceilings, without being supported by the ceilings, and meet the structural soffit above to provide the required fire-resisting compartmentation.

### Elements of structure and compartment walls

To prevent the premature failure of the structure, the load-bearing elements of the building and its compartment walls are required to have a minimum period of fire resistance, in terms of resistance to collapse or failure of load-bearing capacity.

Elements of structure and compartment walls required to have a minimum period of fire resistance of 60 minutes or more, should be constructed of materials of limited combustibility, such as Knauf plasterboards, as defined in Chapter 2 of HTM 81.

Fire resistance periods for structural elements are given in HTM 81, section 6.6, page 35.

Where sprinklers are installed throughout, the requirement for elements of structure and compartment walls to be constructed of materials of limited combustibility does not apply.

### Compartmentation

#### Maximum area

The maximum area of a compartment should not exceed:

- 2000 m<sup>2</sup> in a multi-storey hospital
- 3000 m<sup>2</sup> in a single-storey hospital

#### Fire resistance of compartment walls

The minimum period of fire resistance (integrity and insulation) provided by compartment walls should be as shown in Table 5, below.

#### Compartment/department relationships

The boundaries of departments should be compartment walls.

#### Openings in floors and compartment walls

All openings in floors and compartment walls should be protected to provide at least the same period of fire resistance as the compartment structure.

Table 5 – Minimum periods of fire resistance for compartment walls <sup>1</sup>

Hospital construction	Minimum period (integrity and insulation)
Single-storey hospitals	30 minutes
Sprinklered hospitals (with storeys up to 12 metres above ground level)	30 minutes
All other hospitals including basements and floors over 12 metres above ground	60 minutes

Notes to Table 5:

<sup>1</sup> Subject to the HTM 81 recommendations for the location and fire separation of fire hazard departments in relation to patient access areas.

Examples of duct work passing through compartment and sub-compartment walls (HTM 81 shows further examples)

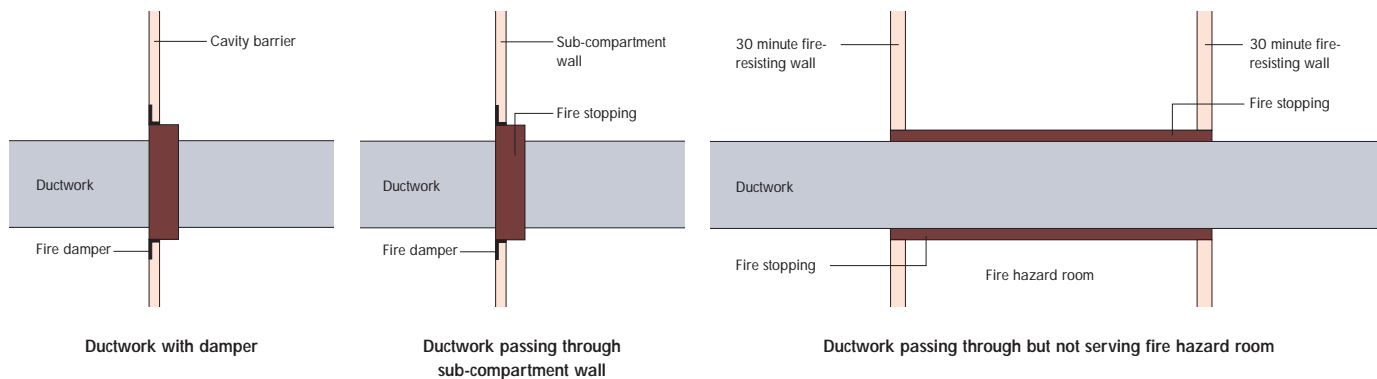

**Protected shafts**

Openings in floors for stairways, lifts, escalators, and pipes and ducts, not complying with the previous paragraph, should be enclosed in a protected shaft, which has the same period of fire resistance (integrity, insulation and, where applicable, load-bearing capacity) as the compartment floor.

The use of protected shafts should be restricted to:

- stairways
- lifts
- escalators
- chutes
- ducts
- pipes

Protected shafts for stairways and lifts should be provided with protected lobbies, except where they are accessed from a hospital street.

Knauf Shaftwall and Firefighting Shaftwall are ideal for lift and service shaft constructions.

**Fire hazard rooms and areas**

HTM 81 identifies fire hazard rooms and areas that should be enclosed in 30 minute fire resisting construction (integrity and insulation). Fire hazard rooms are defined in HTM 81, section 6.28, page 39.

**Ventilation ductwork**

Ventilation ductwork should comply with the requirements of BS 5588: Part 9: 1999: Code of practice for ventilation and air conditioning ductwork, and HTM 2025: Ventilation in healthcare premises.

Ductwork passing through compartment and sub-compartment walls should be provided with fire dampers, as illustrated above and in HTM 81, Section 6.

**Sub-compartments**

If a compartment has a floor area greater than 750 m<sup>2</sup>, or provides access or sleeping accommodation for more than 30 patients, the maximum size of compartment permitted by HTM 81 should be divided into smaller sub-compartments, in order to limit the number of patients who might be affected by a fire.

Sub-compartments should be enclosed by walls with a minimum period of fire resistance of 30 minutes.

Each sub-compartment should be provided with a minimum of two exits, so that a fire in one sub-compartment cannot block the safe exit from others.

**Intensive therapy units**

To reduce the possibility of smoke entering an ITU department, every door opening in the compartment wall, except those off the hospital street, should be provided with a protected lobby, each door of which should provide a minimum period of fire resistance of 30 minutes.

Intensive therapy units should be divided into two sub-compartments, to separate the 'nursing area' from the 'utility area', see diagram below.

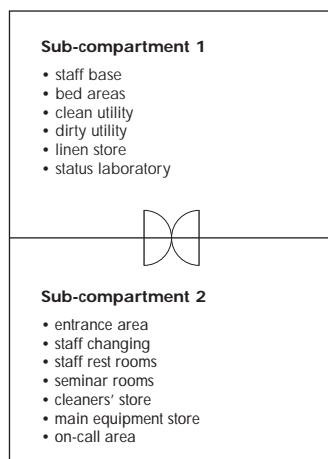

**Periods of fire resistance**

The performance of those elements of the building that are required to achieve a specified period of fire resistance is determined by reference to BS 476: Parts 20–24: 1987.

Table 6 summarises the specific requirements for each element in terms of load-bearing capacity, integrity and insulation.

**Table 6 – Specific periods of fire resistance for building elements**

Part of building	Load-bearing capacity (minutes)	Integrity (minutes)	Insulation (minutes)	Method of exposure
Structural frame (beam or column)	see HTM 81, 6.6	–	–	exposed faces
Load-bearing wall	see HTM 81, 6.6	–	–	each side separately
Compartment floor	60	60	60	from the underside
Compartment wall		60 <sup>1</sup>	60 <sup>1</sup>	each side separately
Single-storey hospitals		30	30	
Sub-compartment wall		30	30	each side separately
Wall to a fire hazard room		30	30	each side separately
Protected shaft	60	60	60	each side separately
Fire-fighting shafts	120	120	120	from side remote from shaft
a) construction separating the shaft from the building	60	60	60	from shaft side
b) construction separating fire-fighting stairway from fire-fighting lift shaft and fire-fighting lobby	60	60	60	each side
Cavity barrier	not applicable	30	15	each side separately
Fire-resisting ceiling (as described in HTM 81)	not applicable	30	30	from below

Notes to Table 6:  
 1 Period may be reduced if sprinklers are installed.

# HOSPITALS



## FINISH CONSIDERATIONS

### Relevant documents

Health Technical Memorandum (HTM) 56: Partitions (especially Section 3: Specification guidance: finishes).

HTM 60: Ceilings.

The Building Regulations 2000 Approved Document B2: Internal fire spread (linings).

BS 6150: 1991: Code of practice for painting of buildings.

### Categories of performance of wall finishes

HTM 56 establishes six performance categories as a means of relating user requirements to the physical and performance characteristics of wall finishes available on the market.

A full categorisation of hospital spaces is given in Appendix E of HTM 56, in which each type of space is graded 1-6 where '1' indicates the highest level of hygiene requirement and '6' the lowest. Typical examples would be a 'Drugs and alcohol recovery room' designated category 3, or an 'Operating theatre' designated category 1.

The 6 performance categories are then cross referred to types of partition surface shown in Table 7 (opposite).

From this table, the designer can establish the type of surface, the degree of moisture resistance and the hygiene level which will be required for a particular room's grade. A finish can then be chosen. 'Applied wall finishes' (Table 9, opposite) then lists the performance categories of the finishes that can be applied to the partition surface type selected to achieve the required category.

### Definitions of performance characteristics of wall finishes

The physical and performance characteristics of wall finishes may be defined as:

- impervious: able to resist the penetration of water, solutions containing detergents, disinfectants and other liquids likely to be encountered in health buildings.

- jointless: without joints or having joints which are sealed by methods and materials which make the whole surface impervious and prevent the collection of dirt and bacteria in the joint.
- smooth: no coarser than brush-applied matt emulsion paint on a flat plastered surface without projections, indents or holes part way through the material.

Moisture resistance:

- high humidity: 25% to 100% relative humidity over an air temperature range of 10°C to 30°C, and able to withstand sustained contact with water and water vapour.
- normal humidity: 25% to 65% relative humidity over an air temperature range of 10°C to 25°C, and able to withstand intermittent contact with water and water vapour.
- hygiene: capable of withstanding the appropriate indicative cleaning routine, as set out below in Table 8 (opposite):

### Applied wall finishes

The finishes listed in Table 9 are suggested as the minimum acceptable for the categories indicated. In each category, several suitable finishes are listed. It is necessary for the specifier to consider the properties of the various materials in respect of:

- durability.
- resistance to fungal/bacterial attack.
- resistance to cracking.
- resistance to abrasion.
- surface spread of flame.

Only then should the final selection be made.

Finishes should be selected with full consideration of capital cost and subsequent maintenance costs.

Consideration should be given to the long term availability of proprietary finishes where an exact match might be required.

### Notes on the selection of wall finishes

- paints: a matt finish is the most suitable for appearance, as gloss finishes accentuate even minor surface imperfections. Spray-applied textured and flecked paints have been found to be very satisfactory in use and appearance.
- PVC sheet: PVC sheet can be fixed with a variety of adhesives and the joints can be welded, making it suitable for use in wet areas. Arrises and internal angles should be radiused to allow for the thickness of the material.
- plastics finishes: proprietary spray-applied jointless finishes are available to provide a hygienic, waterproof, easily cleaned surface suitable for areas where large amounts of water are used for cleaning (e.g. operating departments).

In all cases, the manufacturer of the finishes should be contacted to confirm suitability, bonding instructions, etc. A coat of *undiluted* Knauf Wallboard Primer should be applied prior to any subsequent finish.

### Worked example

For a 'Drugs and alcohol recovery room' where the performance category is 3, it can be established from Table 7 that the following surface types could be specified: 'impervious', 'jointless' or 'smooth', and that this type of room would require 'normal humidity', and 'Hygiene Cat B' (the cleaning routine for which is detailed in Table 8).

From Table 9, opposite, it can then be established that, to the above surface types, the following finishes could be specified: epoxy coating, oil gloss paint, polyurethane coating, spray elastomeric compound, spray paint (multi-colour) gloss, cloth-backed vinyl, PVC sheet, ceramic tiles with epoxy coating, all of which could maintain the category 3 rating.

## Tables 7, 8 and 9

Table 7 describes what kind of jointing is required, what moisture resistance properties will be required and what hygiene levels are required.

Table 8 describes the cleaning routine required for the four hygiene categories shown in Table 7.

Table 9 describes the applied finishes appropriate to meet the criteria described in Tables 7 and 8.

**Table 7 – Categories of performance of partition surface**

Type of partition surface	Meets performance criteria for rooms of grade					
	1	2	3	4	5	6
Impervious	•	•	•	•	–	–
Jointless	•	•	•	–	–	–
Smooth	•	•	•	•	–	–
Moisture resistance:						
high humidity	–	•	–	•	–	–
normal humidity	•	–	•	–	•	•
Hygiene:						
A	•	–	–	–	–	–
B	–	•	•	–	–	–
C	–	–	–	•	•	–
D	–	–	–	–	–	•

### Surface spread of flame

Note that applied finishes may change the surface spread of flame characteristics of the partition. Test results should be obtained from the manufacturer.

For Firecode requirements for surface spread of flame for health buildings, see HTM 56, Section 2.5.4.

### Ceiling finishes

#### Categories of performance

HTM 60 provides a table of six performance categories for ceiling membranes in health buildings. Appendix A gives the performance category for each activity space.

The physical and performance characteristics of ceilings in the above table are described as follows:

#### Physical and performance characteristics of ceilings: physical characteristics of the soffit

In HTM 60 the characteristics of the soffit are defined under six headings:

- smooth
- textured
- imperforate
- perforated
- jointless
- jointed

### Humidity

Ceilings should be capable of withstanding either normal or high humidity:

- normal humidity: 25% to 65% relative humidity over an air temperature range of 10°C to 25°C.
- high humidity: 25% to 100% relative humidity over an air temperature range of 10°C to 30°C.

#### Surface spread of flame

To meet the requirements of the Building Regulations 2000 Approved Document B2, the surface linings of ceilings in health buildings should meet the following classifications:

- ceilings of circulation spaces and shafts: Class 0.
- ceilings of all other rooms: not less than Class 1.

Knauf plasterboards are classified Class 0.

Many membranes rated as Class 1 will also meet the requirements of Class 0. Relevant test data should be obtained from the manufacturer.

#### Cleaning and disinfection

All ceilings in health buildings should be capable of withstanding one or more of the four cleaning routines set out in HTM 60, Table 8, above.

**Table 8 – Categories of cleaning routine for walls**

Daily
<b>A</b> Washing or spray-cleaning with water containing a neutral detergent (disinfectants may be required in certain areas)
Weekly
<b>B</b> Cleaning with a damp mop containing water and a neutral detergent, or with a suction cleaner with a suitable attachment
Periodically
<b>C</b> Quarterly or longer cleaning with a damp mop containing water and a neutral detergent, or with a suction cleaner with suitable attachment
<b>D</b> Quarterly or longer cleaning with a suction cleaner with suitable attachment

**Table 9 – Applied wall finishes**

Applied wall finish	Meets performance criteria for rooms of grade					
	1	2	3	4	5	6
Liquid coverings:						
Epoxy coating	•	•	•	•	–	–
Paint:						
Emulsion – matt, silk	–	–	–	–	•	•
Oil – gloss <sup>1</sup>	•	•	•	•	•	•
Oil – semi-gloss, eggshell <sup>1</sup>	–	–	–	–	•	•
Vinyl – gloss	–	–	–	–	•	•
Polyurethane coating	•	•	•	•	–	–
Spray elastomeric vinyl compound	•	•	•	•	–	–
Spray paint (multi-colour) gloss	•	•	•	•	•	•
Flexible pre-formed coverings:						
Cloth-backed vinyl covering	•	•	•	•	–	–
Paper-backed vinyl covering	–	–	–	–	•	•
PVC sheet (1 mm thick with welded joints)	•	•	•	•	–	–
Wallpaper	–	–	–	–	–	•
Wallpaper with spongeable surface	–	–	–	–	•	•
Hard pre-formed coverings:						
Ceramic tiles						
cement grouting	–	–	–	•	–	–
epoxy grouting	•	•	•	–	–	–
Plastic laminate with sealed joints	•	•	•	–	–	–

#### Note to Table 9:

<sup>1</sup> Gloss finishes accentuate even minor imperfections. We recommend the use of skim plaster if a gloss finish is specified.

## HOSPITALS



## FIXINGS CONSIDERATIONS

**Relevant documents**

Health Technical Memorandum (HTM)  
 70: Fixings  
 HTM 56: Partitions (especially Section 5:  
 Site practice and Appendix A)  
 HTM 55: Windows  
 HTM 57: Internal glazing  
 HTM 58: Internal doorsets  
 HTM 59: Ironmongery  
 HTM 62: Demountable storage systems  
 HTM 63: Fitted storage systems  
 HTM 64: Sanitary assemblies  
 HTM 66: Cubicle curtain track  
 HTM 67: Laboratory fitting-out systems  
 HTM 68: Duct and panel assemblies  
 HTM 69: Protection  
 HTM 2015: Bedhead services  
 BS 5234: Partitions (including matching  
 linings) Part 2: 1992: Specification for  
 performance requirements for strength  
 and robustness including methods of test.

**Provision of fixings**

Consideration should be given to the types and positions of fixings to be used for components that require support from the partition, particularly for components such as sanitary assemblies and demountable and fitted storage, where additional strengthening of the partition will be required.

Proprietary fixing devices should be used in accordance with the manufacturers' recommendations, using a Factor of Safety of 2 to 4.

Knauf Drywall partitions can be designed to accept most loadings encountered in health buildings. Tests carried out have shown that the heaviest loadings for cantilevered worktops and storage units in HTM 63 can be supported by the use of suitably fixed softwood grounds (see page 25). The cantilever brackets or

corbel carcasses should be screwed to timber grounds with suitable wood screws. Alternatively, 38 mm wide grounds screwed to metal studs are suitable. Plasterboard skins should be screwed to timber grounds.

Knauf Drywall Technical Services can provide advice and guidance on the provision of fixings to our systems.

**Location and types****of components to be fixed****Windows to walls**

HTM 55 (Windows) should be consulted for the installation of most windows in health buildings. Items 6.2 and B14 in the specification to HTM 55 cover the fixing of windows into prepared openings, or built in as work proceeds.

**Partitions to floors, soffits and structure**

HTM 56 (Partitions) describes fixing in Section 5: Site practice and also in Appendix A.

**Internal glazing to partitions**

Advice on the installation of internal glazing is given in item 5.4 in HTM 57. Fixing methods are very similar to those for doorsets.

**Doorsets to partitions and floors**

The fixing of doorsets is critical to their performance in resisting slamming, impacts and forces caused by closers and general use. HTM 58 (internal doorsets) considers different frame thicknesses in Section 3.1, and gives advice on the installation of doorsets in Sections 5.4 and 5.5. A standard pattern of fixing holes is given in Section 5.4. Appendix C includes clauses C7 and C8 on installation and fixings, see page 25.

With the requirement for smoke resistance for many fire doors, the fixing of doors to their frames and frames into partitions becomes crucial. Gaps between door leaves and frames should not exceed the widths specified, distortion of frames must be avoided and gaps between frames and faces of openings must also be filled to prevent the passage of smoke, as described in HTM 58.

**Ironmongery to doors and partitions**

HTM 59 (Ironmongery), Section 2.4 gives guidance on the fixing of items to doors. Problems are often experienced when fixing ironmongery with the fixing screws supplied, particularly when attempting to use wood screws to fix into thin wood, plastics or metal.

**Ceilings to soffit and partitions**

HTM 60 (Ceilings), Section 5.2 deals with the installation of ceilings. Manufacturers' recommendations and structural codes of practice should be followed.

**Storage systems to partitions**

Appendix B of HTM 70 (Fixings) gives the results of loading tests on partition-mounted furniture units, carried out for the DoH in 1986. The data included refers to both demountable storage systems (HTM 62), fitted storage systems (HTM 63) and laboratory fittings (HTM 67).

**Sanitary assemblies to partitions, floors and panels**

HTM 64 (Sanitary assemblies), item 5.2 gives advice on the installation of sanitary appliances.

Partitions may require strengthening to take the imposed loadings recommended. BS 5234 and HTM 56 give advice on this aspect, see page 25.

#### Signs to partitions and ceilings

HTM 65 (Signs) gives guidance on the fixing of signs. As internal signs are fairly lightweight, this does not normally present a problem.

#### Cubicle curtain tracks to ceilings and partitions

HTM 66 (Cubicle curtain track) gives guidance on the fixing of tracks. These may be fixed to soffit, partitions or suspended ceilings.

#### Laboratory fittings to partitions and floors

HTM 67 (Laboratory fitting-out systems) gives advice on the installation of laboratory fittings. Some framing to benches may require fixing to the floor or soffit.

#### Duct and panel assemblies to partitions and floors

HTM 68 (Duct and panel assemblies) gives advice on the fixing of panels to partitions. These may have to be trimmed to form openings to receive the panels, see also HTM 56.

#### Protection to partitions and doors

Protection is generally fixed to partitions and doors. Push plates or kicking plates may be fixed with small screws or adhesive. Heavier buffer rails or similar applied protection will require a stronger partition or extra reinforcing members within the structure. Screwed or bolted fixings are required. See also HTM 69 (Protection), and pages 9 'Protection' and 16 'Robustness' of this document.

#### Equipment and services to partitions and soffit

HTM 56, which is derived from BS 5234, gives advice and test data on the fixing of equipment and services to partitions and structural soffits. These can vary from lightweight fastenings to heavy special fixings, which may also be included in engineering specifications.

#### Cavity anchors

Cavity anchors are designed for light duty fixing into single and double sheet plasterboard partition faces. Retained anchors, which remain in position allowing the fastener to be taken out and replaced, are usually to be preferred to types that fall into the cavity, (see Knauf Drywall anchor, page 24).

For load tests on cavity fasteners, see HTM 70: Appendix B.

#### Bedhead services

HTM 2015 (Bedhead services) gives advice on the provision of bedhead services, in particular patient-to-nurse call systems. The various types of installation are described.

For surface-mounted bedhead services Knauf Drywall generally recommend fixing with Drywall Screws into studs at 400 mm centres.

Knauf Technical Services can provide advice on the use of Knauf Drywall systems for any of the above applications.



## HOSPITALS



## ROBUSTNESS

### Relevant documents

Health Technical Memorandum (HTM) 56: Partitions (especially Section 2.3: Strength and stability).

HTM 60: Ceilings.

BS 5234: Partitions (including matching linings) Part 1 and Part 2: 1992: Specification for performance requirements for strength and robustness including methods of test.

BS 8212: 1995: Code of practice for dry lining and partitioning using gypsum plasterboard.

### Objectives of regulations

HTM 56 provides a list of loads and impacts that partitions in hospitals should be able to withstand.

Appendix A of HTM 56 provides specifications and details for hollow plasterboard partitions.

The Knauf Drywall solutions shown on page 19 can all meet the criteria set out in Appendix A.

Appendix B of HTM 56 sets out performance requirements for strength and stability of partitions. The tests and levels of acceptance are taken from BS 5234: Part 2.

BS 5234: Part 2: 1992: sets out methods for testing a sample partition with a door for structural strength and robustness.

Partitions should be capable of meeting the requirements of BS 5234: Part 1: 1992 within the appropriate duty category. The categories applicable to hospitals are: Medium duty (office); Heavy duty (public circulation and industrial areas); Severe duty (major circulation and heavy industrial areas). See also 'Protection', page 9.

### Requirements for robustness

Knauf Drywall plasterboard partitions can be specified to meet the following requirements from BS 5234: Part 2: 1992:

- a large, heavy person leaning against a partition, or standing on a ladder leaning against a partition, should not cause significant flexing of the partition, cracking in adjacent finishes or an unacceptable degree of movement in shelves, worktops etc. fixed to the partition.
- door slamming should not damage a partition or its finishes.
- heavy impacts caused by mobile equipment should not displace a partition, cause its collapse or cause damage not easily repaired.
- soft body impact caused by shoulder impact or by persons falling against it should not damage a partition.
- hard body impacts from trolleys, wheelchairs etc. should neither perforate the partition nor cause damage that cannot be easily repaired.
- fixings for lightweight items, such as mirrors, small fire extinguishers and towel dispensers, may be required anywhere on the face of an unreinforced partition (see pages 24-25).
- fixings for heavyweight items, such as wash basins, worktops, cupboards and shelving may be required. These may require additional framing in hollow partitions (see page 25).
- all sanitary appliances are required to support a live load of 140 kg, which may need to be supported by the partition (see page 25).

- differential pressures caused by air movement around and through the building should not cause any perceptible movement in the partition. This may require particular consideration to be given to the perimeter fixings of hollow plasterboard partitions.

With regard to the fixing of basins, sinks or urinals to hollow plasterboard partitions, consideration must be given to the fixings to avoid indentation by brackets or fixing plates. The use of plastic laminate-faced back panels, also acting as splashbacks, is recommended. Additional framing and trimming may be required in hollow partitions (see page 25).

Knauf Drywall systems are available to meet all the above criteria; please consult Knauf Drywall Technical Services for advice.

### Robustness of ceilings

A ceiling system should normally be able to support:

- dead loading: from the normal range of surface-mounted or recessed ceiling fixtures, e.g. lighting fittings and lightweight services, such as cables in the ceiling void.
- live loading: exerted as an upward and sideways thrust during normal cleaning operations.

Knauf Drywall ceilings can be designed to meet all normal loads.

HTM 60, section 3.7, page 8 includes a table showing three grades of load-carrying capacity for structural members of ceiling suspension systems.

## SPECIFICATION TIPS

### Metal studs – speed, accuracy and economy

The specification of metal studs gives particular advantages over timber:

- reduced waste.
- increased speed and ease of erection.
- higher accuracy, no movement or twisting due to shrinkage.
- reduced customer care issues.

There is also a greatly reduced chance of use by other trades for non-associated tasks. Always ensure that Knauf Drywall metal studs are used within Knauf Drywall partition systems to ensure the validity of all performance ratings and the warranty.

### Paper tape

Always specify the use of Knauf Joint Tape for jointing plasterboards in ceiling applications. The use of paper tape significantly reduces the chances of cracking due to movement of the background.

### Reducing wastage

Wastage of plasterboard on sites can be reduced by ensuring that the correct board length is chosen to suit the storey heights. Often, over-length boards are specified which then have to be cut-down, increasing working time and waste.

For further information on waste management, please refer to our Environmental brochure, available from our Literature Hotline: 08700 613 700.

### Recessed lights and other penetrations

When specifying recessed lighting and other penetrations through walls and ceilings, consider the effect on the system's performance with regards to fire and acoustic ratings. Always ensure the manufacturer of the penetration has taken these into account.

### Achieving high finish levels

When deciding on which finish to apply to plasterboard, consideration should be given to the level of flatness that is required so that it suits the interior design and lighting conditions. For example, natural light at a shallow angle tends to highlight surface level differences, and features such as rails require a uniformly flat surface in order to be correctly mounted.

On a taped and jointed finish, the maximum increase of the crown of the joint allowed in BS 8212:1988 is 3 mm when measured using a 450 mm straight edge. A smaller maximum increase can be specified, but will be more time-consuming to achieve. The use of Knauf Tapered Edge plasterboards is recommended when taping and jointing. If a uniformly flat surface is required then a Knauf skim plaster finish should be specified.

If specifying a taped and jointed plasterboard finish, undiluted Knauf Wallboard Primer should be applied prior to the final applied wall finish. The use of Wallboard Primer equalises suction across the surface and reduces the chance of the joints being seen through the finish. It also reduces moisture absorption and the risk of discolouration.



When checking the standard of jointing prior to completion, the use of lighting similar to that expected when occupied will provide the most accurate check, and subsequently reduce the possibility of customer care issues relating to the finished surface.

### Sequence

The British Standard Code of Practice for plasterboard partitions and dry linings (BS 8000: Part 8: 1994) recommends the following sequence of work:

Fix ceiling linings first, then partitions, followed by wall linings. Whenever it is practical to do so, apply wall linings in sequence working away from doors and windows and towards internal angles. As far as possible, locate paper bound board edges at salient corners.

In hospitals, the extensive use of suspended ceilings can make building outside of this sequence preferable.

### Service accommodation and partially boarded partitions

In hospital environments, it is often necessary to accommodate a large number of services above ceiling level. On occasion, this means the plasterboard extends only to a height above suspended ceiling level leaving a gap for the services to run through. In these situations, no fire or acoustic performance can be guaranteed and it is necessary to consider the effect on the overall strength and, therefore, maximum design height of the partition.

The partition must also be capped off with plasterboard in order to prevent fibre migration if insulation has been specified in the void.

Generally, it is recommended that no more than 25% of the total height is left unboarded without diagonal bracing being installed above a suspended ceiling. The bracing can be made from Knauf 'C' Stud or 'U' Channel and should be attached so that it forms a 45° brace between stud and soffit. These should be installed on every other stud and on alternate sides of the wall.

# HOSPITALS

## DESIGN SOLUTIONS

When designing hospitals, there are various technical and regulatory requirements that must be met. Recognising this, Knauf Drywall has created a simple, optimised range of cost-effective solutions.

Detailed in this section is a range of solutions that you can specify with confidence. Knauf Drywall Technical Services are on hand to advise on any unusual or more onerous requirements you may have.

## KNAUF DRYWALL SOLUTIONS: PARTITIONS

Knauf Drywall's revolutionary Acoustic 'C' Stud system has been specifically developed for hospital usage, with one basic single layer partition type covering the vast majority of partition requirements for modern hospital environments.

This partition type, consisting of 70 mm Knauf Acoustic 'C' Studs clad each side with a single layer of 15 mm Knauf Soundshield, meets all the requirements of BS 5234: Part 2: 1992 for 'Heavy Duty' with an overall width of just 100 mm. The single layer design means that installation time, and cost, can be drastically reduced.

The only difference in the solutions is the amount of insulation included to provide a sound reduction of 43dB, 48dB or 53dB. We can, of course, offer other systems for higher acoustic or fire ratings. Contact Knauf Drywall Technical Services for more information.





These solutions will cover the vast majority of partitions within a hospital environment. Occasionally, though, solutions may be required with a greater acoustic or fire performance – please contact Knauf Drywall Technical Services for details of partitions to meet specific higher performance requirements, or refer to The Complete Drywall Manual, or online at [www.knaufdrywall.co.uk/themanual](http://www.knaufdrywall.co.uk/themanual)

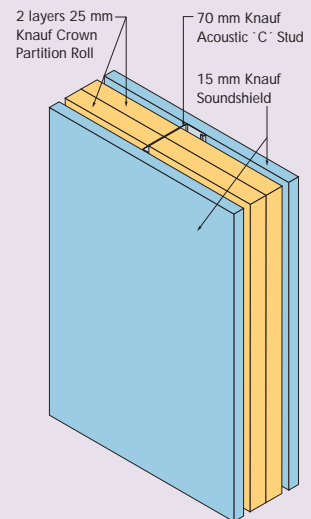
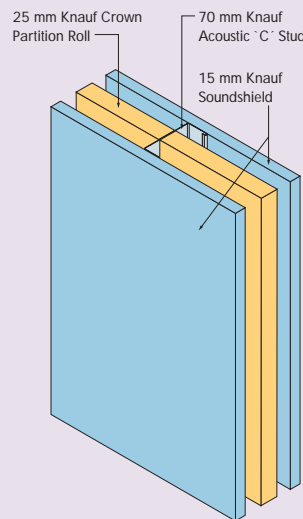
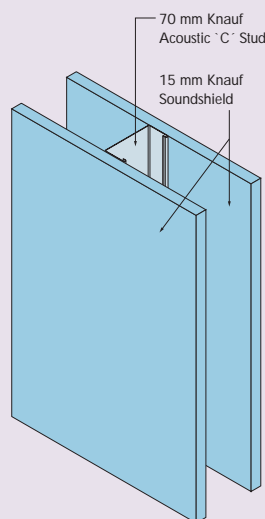
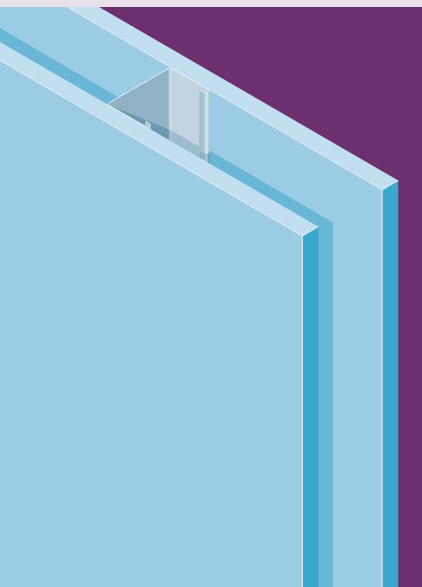

**Notes to Partitions:**

- 1 For constructions which require a figure higher than 53dB, please call the Knauf Drywall Technical Services Department.
- 2 The fire ratings of these partitions are to the BS 476 standard. For details of performances to BS EN 1364-1:1999 please contact Knauf Drywall Technical Services. It should be noted that in some instances double boarded partitions will be necessary to suit the BS EN 1364-1 standard.

**Solution 1 – 43dB Partition<sup>1</sup>**

- 15 mm Knauf Soundshield
- 70 mm Knauf Acoustic 'C' Stud at 600 mm centres
- 100 mm overall width
- 30 minutes fire resistance<sup>2</sup>
- 43dB Rw airborne sound
- 3700 mm maximum height (Severe duty)  
4500 mm maximum height (Heavy duty)

**Solution 2 – 48dB Partition<sup>1</sup>**

- 15 mm Knauf Soundshield
- 70 mm Knauf Acoustic 'C' Stud at 600 mm centres
- 25 mm Knauf Crown Partition Roll
- 100 mm overall width
- 60 minutes fire resistance<sup>2</sup>
- 48dB Rw airborne sound
- 3700 mm maximum height (Severe duty)  
4500 mm maximum height (Heavy duty)

**Solution 3 – 53dB Partition<sup>1</sup>**

- 15 mm Knauf Soundshield
- 70 mm Knauf Acoustic 'C' Stud at 600 mm centres
- 2 x 25 mm Knauf Crown Partition Roll
- 100 mm overall width
- 60 minutes fire resistance<sup>2</sup>
- 53dB Rw airborne sound
- 3700 mm maximum height (Severe duty)  
4500 mm maximum height (Heavy duty)

# HOSPITALS

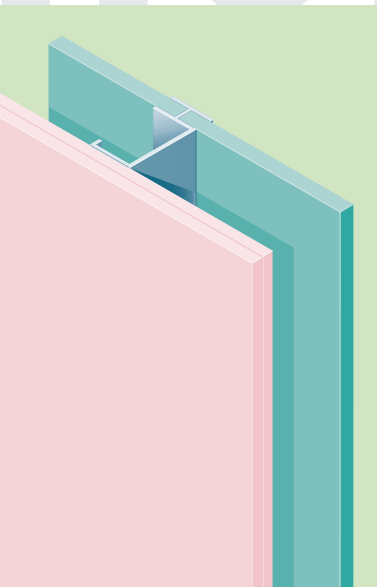

## KNAUF DRYWALL SOLUTIONS: SHAFTWALL

Knauf Shaftwall is a heavy duty partition system that can be wholly constructed from one side only, making it ideal for situations such as lift shafts, where it would be impractical to work from the open shaft side. Special Knauf 'C-T' Studs are used to retain fire- and moisture-resistant Knauf Coreboard on the shaft side without the need for screws.

The use of Knauf Fireshield on the lobby side allows for a high quality finish to be applied, as with any Knauf plasterboard.

Fire ratings of up to 2 hours can be achieved, and Knauf Shaftwall can be designed for use with pressurised shafts. Contact Knauf Drywall Technical Services for more details.

### Notes to Shaftwall:

- 1 For comprehensive information on the Knauf Shaftwall system, please refer to 'The Complete Drywall Manual.'
- 2 The fire ratings of these Knauf Shaftwall partitions are to the BS 476 standard. For details of performances to BS EN 1364-1, please contact Knauf Drywall Technical Services.

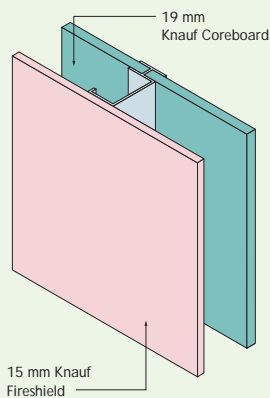

### Solution 1

- 15 mm Knauf Fireshield (lobby side), and 19 mm Knauf Coreboard (shaft side).
- 60 mm Knauf 'C-T' Studs at 600mm centres (92 mm and 146 mm 'C-T' Studs also available).<sup>1</sup>
- 60 minutes fire resistance<sup>2</sup>

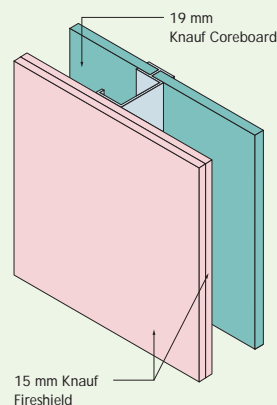

### Solution 2

- 2 layers 15 mm Knauf Fireshield (lobby side), and 19 mm Knauf Coreboard (shaft side).
- 60 mm Knauf 'C-T' Studs at 600 mm centres (92 mm and 146 mm 'C-T' Studs also available).<sup>1</sup>
- 120 minutes fire resistance<sup>2</sup>

# BESPOKE HOSPITAL SOLUTIONS



## Special finishes

Knauf Drywall plasterboard partitions provide an ideal background for a wide array of applied wall finishes to suit surface performance requirements throughout the hospital environment (see pages 12 and 13 – Finish Considerations).

In all instances, the Knauf Drywall partition should be fully taped and jointed, and an undiluted coat of Knauf Wallboard Primer applied, prior to application of the special finish. This will minimise the risk of damage to the plasterboard, and will ensure that the fire and acoustic properties of the partition are maintained. The manufacturer of the special finish should be contacted to advise of its suitability for use over plasterboard.

In the case of ceramic tiles, the weight of the tiles applied should be no greater than 32 kg/m<sup>2</sup>, and the stud centres reduced to a maximum of 400 mm.

## Radiological screening areas

In order to minimise the risk of exposure of patients and staff to X-Rays in diagnostic and therapy departments, special consideration needs to be given to the design of systems and the materials used in these areas.

Knauf metal stud partitions provide a simple and effective solution when used in conjunction with lead plasterboards. Knauf Drywall Technical Services can recommend specialist companies that pre-bond lead of the required thickness to Knauf plasterboard, ensuring a high-quality and stable product.

Pre-bonded lead plasterboard is typically supplied in 600 mm wide panels, due to the weight of the lead. This also means the panels are only available in square edge. A seamless finish can be achieved by the application of Knauf plaster, or by overboarding with tapered edge Knauf plasterboard and then taping and jointing. Any decorative or special finish that can normally be applied to plasterboard may then be used.

The weight of the lead and the need for an impervious shield must be taken into account when detailing and specifying the partition. Stud centres may need to be reduced, or stud gauge or size increased. Doors may weigh more than usual and special consideration will need to be given to detailing door jambs. Extra lead infill or lead tape (depending on the lead thickness) will be required over the studs at joints between lead plasterboard to maintain the integrity of the lead shielding. In most instances, normal Knauf Drywall Screws can still be used.

Knauf Drywall Technical Services have details to cover most applications – contact us when you have received details of the level of screening required from the National Radiological Protection Board.

## Faraday Cages

Rooms housing devices that are used for measuring very small electrical signals (such as EEG or EMG) are sometimes required to be made impervious to electrostatic fields, in order to reduce the effects on these measurements by outside electrostatic noise sources.

The way this is achieved is by constructing a Faraday Cage. This normally requires a metal mesh or foil to be included in the doors, walls, ceiling, floor and (if they must be present) the windows. All of the mesh must be connected together and connected to earth.

Knauf Drywall metal stud partitions and suspended ceilings provide an ideal mounting for the metal mesh directly to the studs and channels, prior to boarding. For more information contact Knauf Drywall Technical Services.

# HOSPITALS



## KNAUF DRYWALL SOLUTIONS: CEILINGS

Knauf Drywall offers a range of ceiling systems to meet the performance requirements of the various environments within hospital locations. Strength, fire, thermal, sound and vapour permeability can all be simply adjusted to meet a range of criteria.

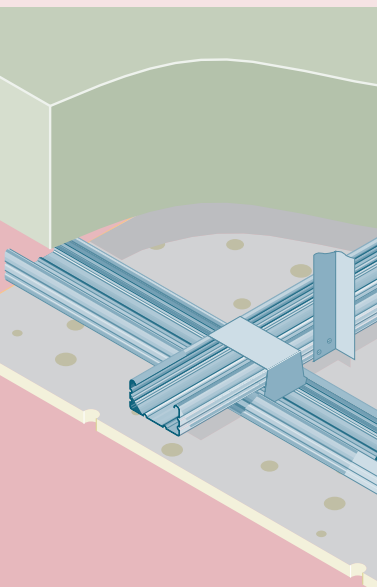

### Suspended Ceilings

The Knauf MF Ceiling is a versatile system allowing the easy creation of different shapes and features, such as bulkheads and lighting coffers.

A wide range of void depths can be accommodated, and fire ratings of up to 2 hours achieved with the correct boarding.

For very shallow voids, the Knauf C-Form II system can be used. Strong Knauf 'C' Channels provide the required support in a single layer grid, reducing the minimum void depth and simplifying installation.

More comprehensive information on Knauf Ceiling Systems can be found in The Complete Drywall Manual, online at [www.knaufdrywall.co.uk/themanual](http://www.knaufdrywall.co.uk/themanual), or call Knauf Drywall Technical Services on 01795 416259.

### Apertura Ceilings

Acoustic reverberation can be an issue in open areas such as corridors, staircases, waiting rooms and entrance halls, and can affect the intelligibility of speech and public announcement systems. Such reverberation can normally be effectively controlled by the installation of a suitable sound absorbing ceiling system, such as Knauf Apertura.

Knauf Apertura is a range of high quality perforated and patterned plasterboards that, with a minimum 60 mm void depth, all achieve a Class D absorptive material rating under BS EN ISO 11654: 1997. With the correct choice of style, void depth and insulation, many of the Knauf Apertura range will achieve Class C.

In addition to high sound absorptive qualities, Knauf Apertura is a highly decorative product, designed to provide a unique seamless aesthetic finish.

Contact Knauf Drywall Technical Services on 01795 416259 for help in specifying the Apertura system.

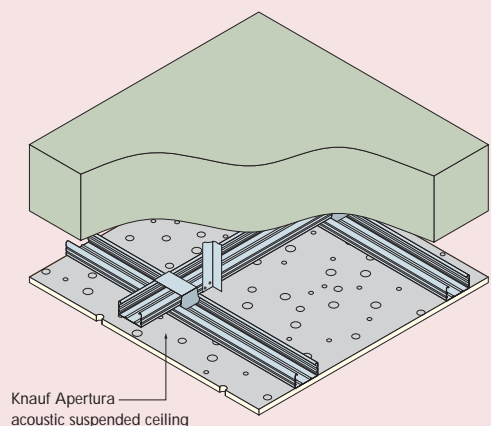
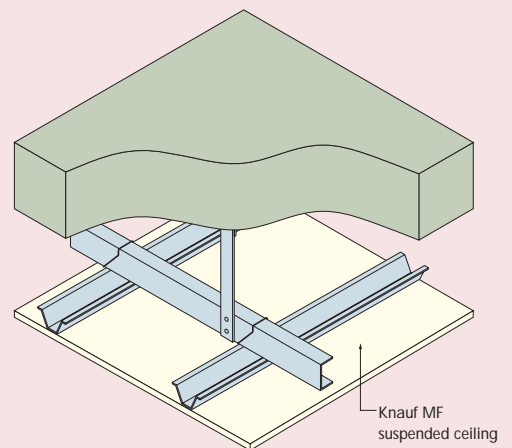

## BEST PRACTICE DETAILING

Hospital construction has specific detailing requirements. Set out in this section are Knauf Drywall's Best Practice Solutions for the more common issues. A full range of standard design detailing can be found in The Complete Drywall Manual, or online at: [www.knaufdrywall.co.uk/themanual](http://www.knaufdrywall.co.uk/themanual)

For further advice, please contact Knauf Drywall Technical Services on 01795 416259.

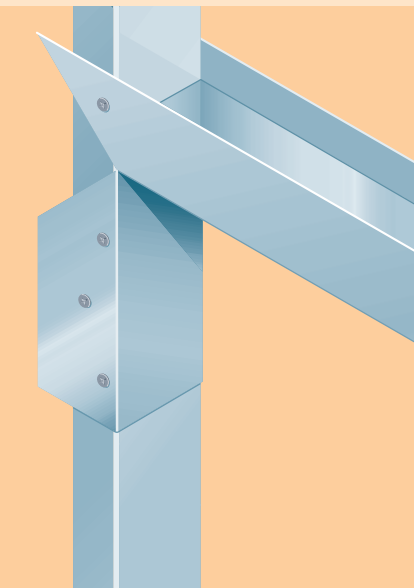

## LINTEL DETAILS

### Notes to lintels:

Based on door weights of up to 50 kg. For higher door weights, please contact Knauf Drywall Technical Services on 01795 416259.

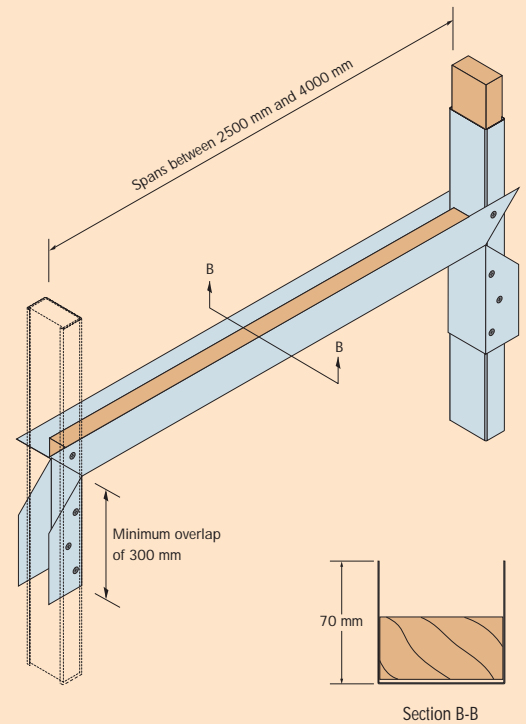
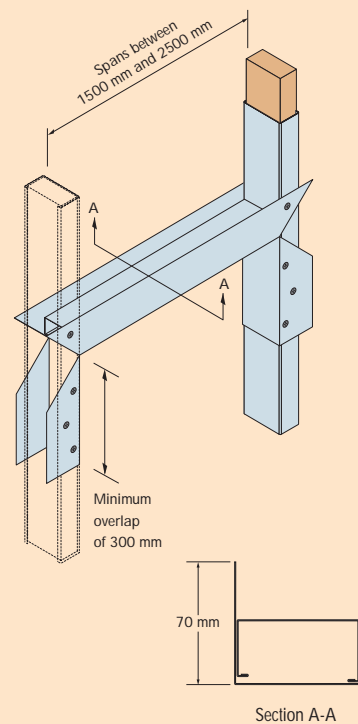

# HOSPITALS

## STRUCTURE AND FIXINGS

### Jamb for light door

Suitable for doors weighing up to 25 kg.

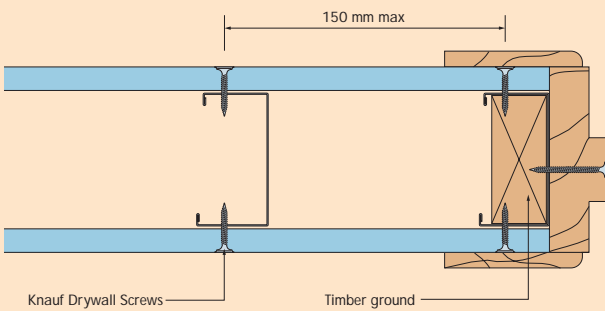

### Jamb for medium weight door

Suitable for doors weighing up to 50 kg. Complies with HTM 56 and BS 5234.

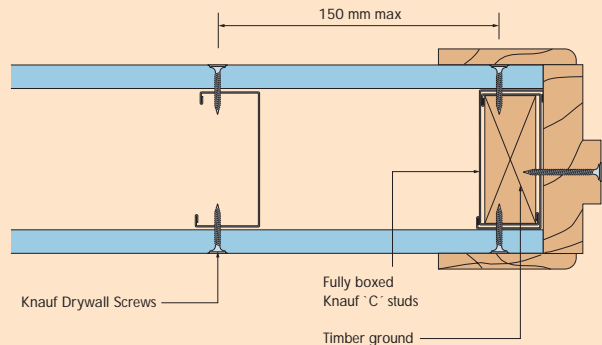

### Jamb for heavy door

Suitable for doors weighing up to 100 kg.

For door weights above 100 kg, please contact Knauf Drywall Technical Services.

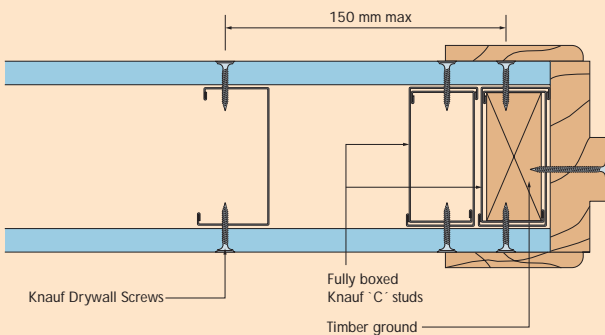

### Lightweight fixings parallel to surface

Suitable for lightweight fixings where the applied load is fixed and continuous, to a maximum of 20 kg. Complies with HTM 56 and BS 5234.

- Suggested applications: mirrors, pictures, light fixings, coat hooks.

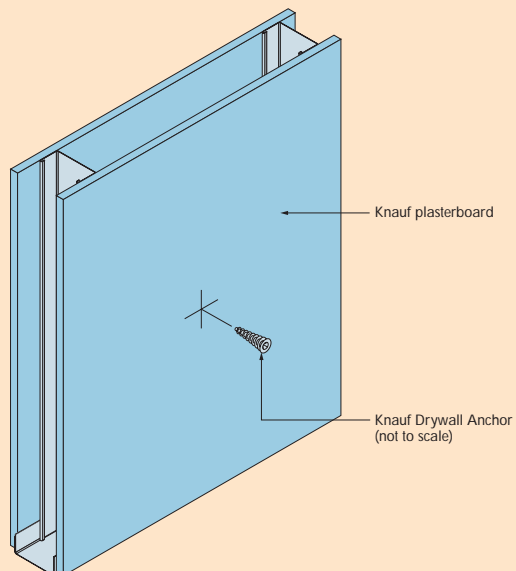

### Medium weight fixings parallel to surface

Suitable for medium weight fixings where the applied load is fixed and continuous, and for lightweight fixings where the load may be subject to some movement (e.g. through removable objects). Complies with HTM 56 and BS 5234.

- Suggested applications: radiators, curtain rails.

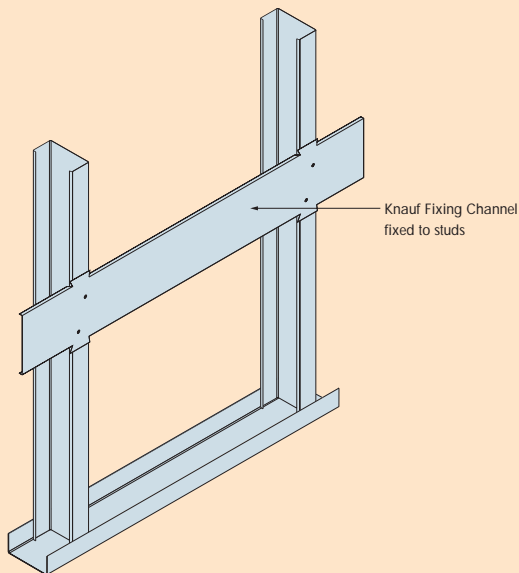

### Heavyweight fixings parallel to surface

Suitable for heavyweight fixings where the applied load is fixed and continuous, and for medium weight fixings where the load may be subject to some movement (eg. through removable objects), to a maximum of 40 kg/lin.m. Complies with HTM 56 and BS 5234.

- Suggested applications: bath (lateral location only), cupboards, shelving, handrails.

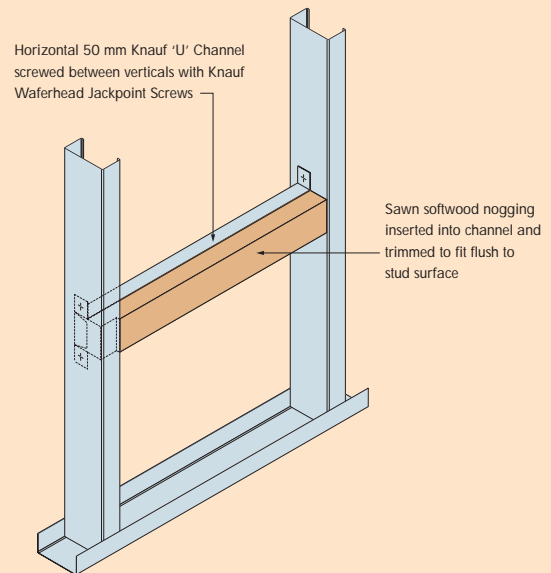

### Heavyweight fixings with moment

For use where the applied load is not directly adjacent to the board surface, thus producing a twisting force that the other fixing details are not capable of withstanding. It is also suitable for fixing items that are likely to receive rougher than usual treatment. Complies with HTM 56 and BS 5234.

- Suggested applications: TV mounting arms, pay telephones and hoods, disabled grab rails.

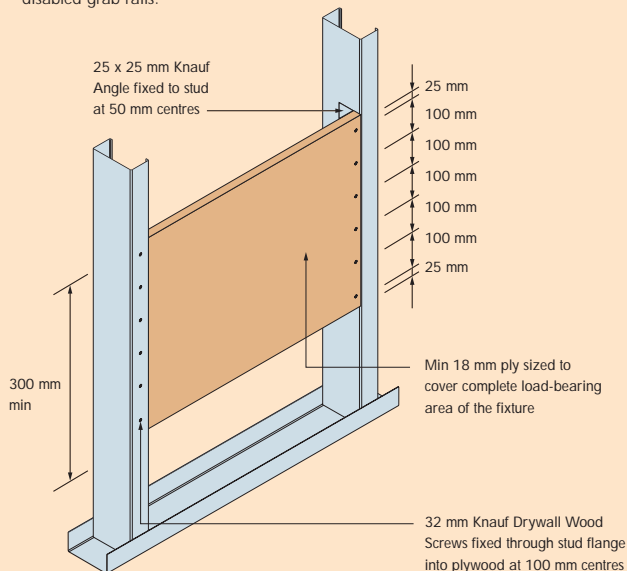

# HOSPITALS

## SERVICES PENETRATIONS

### Conduit/pipework penetration

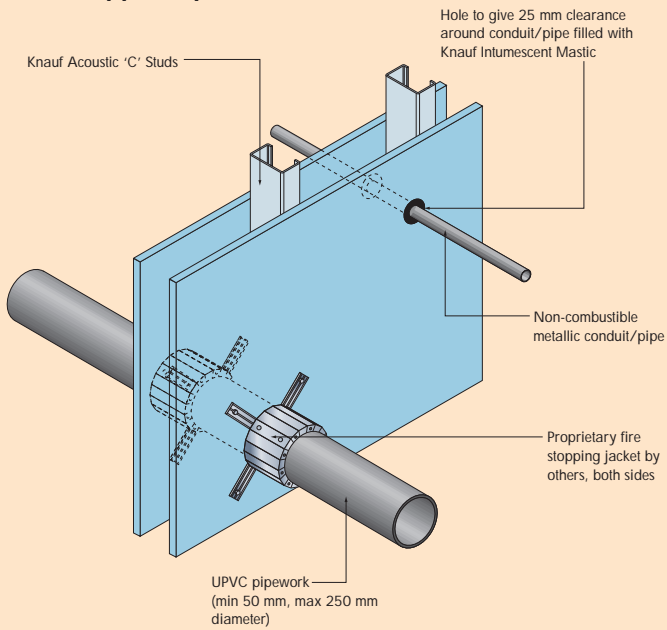

### Cable tray penetration with demountable fire stopping

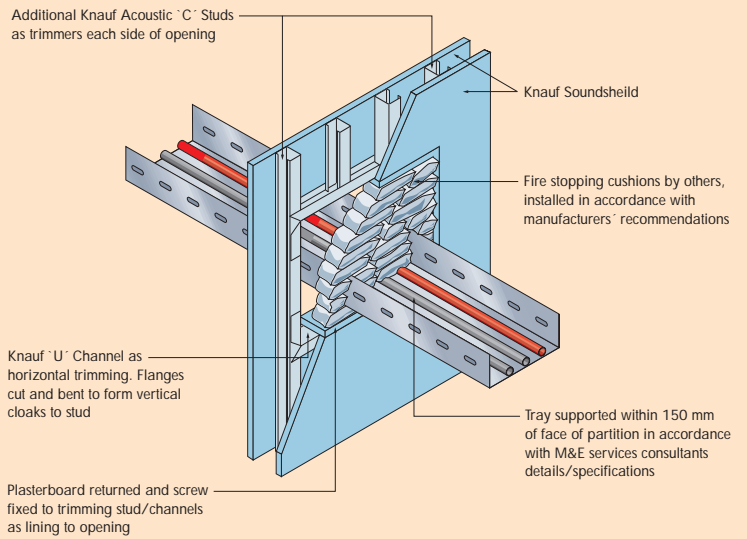

### Cable tray penetration

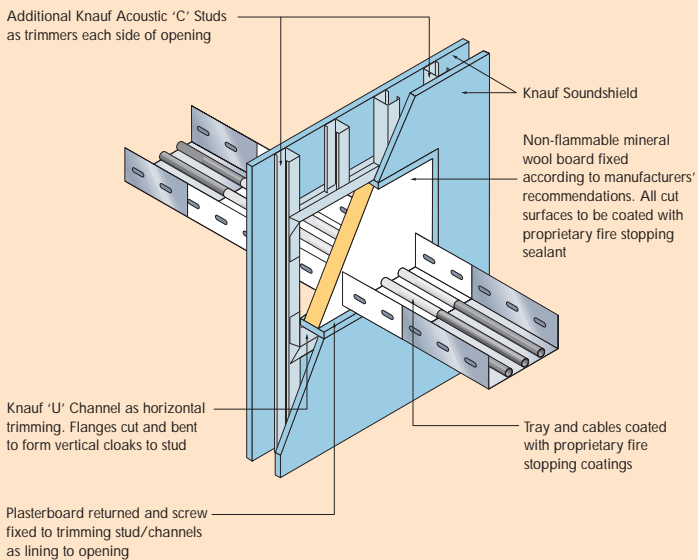

### Trunking penetration

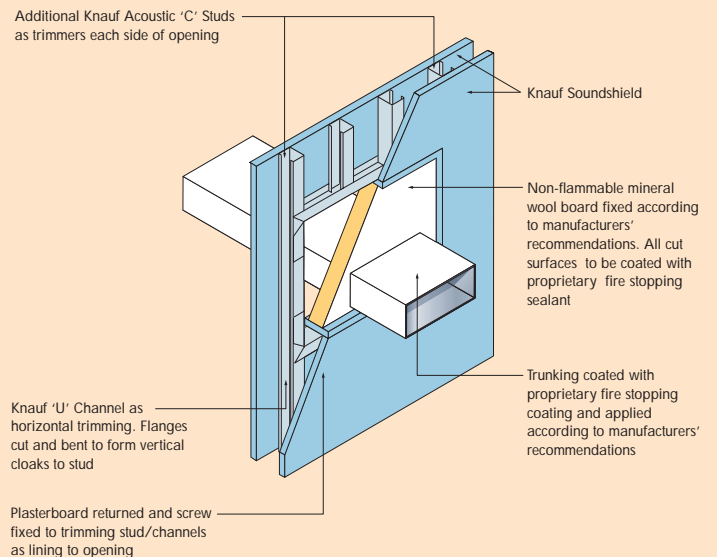

Note:  
Trunking and ductwork to be self-supporting

### Partitions with access to one side only at high level

Often in Hospital developments, there is a requirement to construct partitions (generally corridors) next to high level service runs. If the services have already been installed then it can be impossible to reach both sides of the partition to fix the boarding at high level. This detail enables the boarding at high level to be installed from one side only, in the same way as a shaftwall, but allowing a high standard of finish below ceiling level. Knauf 'I'-Studs and Knauf Angles are used to retain Knauf Coreboard above the ceiling level.

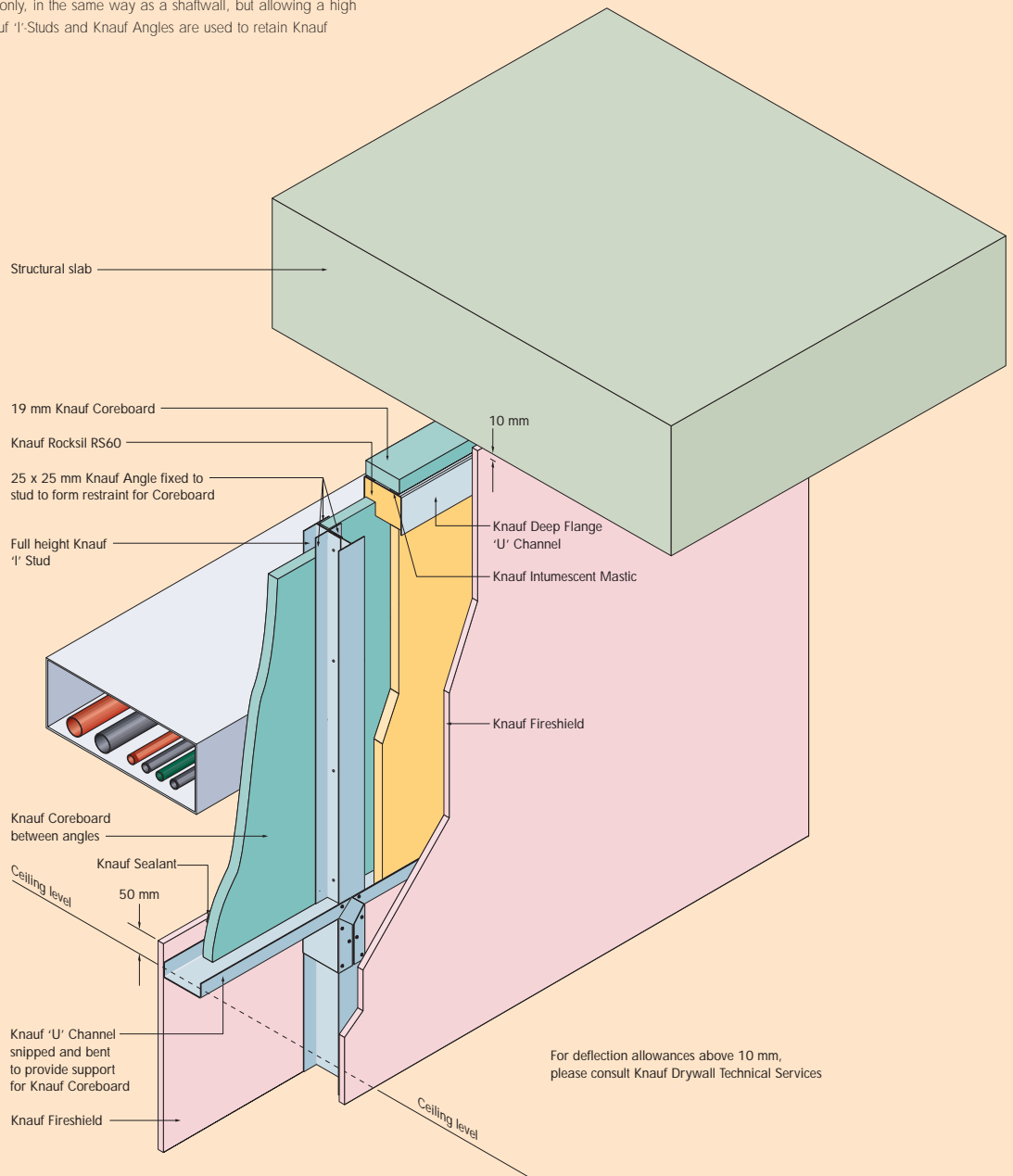

# HOSPITALS



## Edinburgh Royal Infirmary

The new Edinburgh Royal Infirmary is one of the largest PFI projects undertaken to date in the UK. The £180 million hospital which covers almost 100 acres will eventually provide 869 beds and 24 operating theatres and will employ some 5,000 staff. It will be one of the most technically modern facilities in Europe.

It replaces the existing Royal Infirmary of Edinburgh and also incorporates a medical school for the University of Edinburgh.

Knauf Drywall were involved from an early stage and worked with the design team to formulate a value engineered package which was capable of reducing cost and build time and simplifying partition types, all without compromising the performance criteria and finish required by the client.

Knauf Drywall were chosen to participate in this project because of the pro-active approach taken by the Knauf Drywall

team in gaining an understanding of the project requirements, working with architects and contractors to deliver the appropriate solutions.

One of the many challenges facing Knauf Drywall was the development of partitions which incorporated or carried large volumes of services including medical gases, support rails for medical equipment, bed head trunking to carry electrical services, or docking devices to secure beds in position, all of which were a key part of the design brief.

Various options were considered including the traditional method of fixing "plywood" within the partitions to accommodate the additional loads. This raised additional issues over costs, and more importantly, the possibility of changes to equipment during the four year Build Program.

The challenge was eventually overcome by applying some basic engineering logic. All loads, irrespective of the system

adopted, would be transferred back to the studs. By reducing the stud centres from 600 mm to 400 mm all services could be fixed directly back to the studs and negate the need for 70% of the additional timber supports.

This allowed a high degree of flexibility for the client and contractors alike, and more importantly, a significant cost saving was achieved.

The vast size of the project also held logistical challenges. The frequency of deliveries and the number of sub-contractors working on the hospital meant that Knauf Drywall had to devise a plan to overcome these issues. A simple but effective colour-coding system was developed to ensure that each sub-contractor received the correct product, and a complicated material scheduling exercise meant that the product was available when required both direct and ex-stock via our distribution network.



### Contract information

Client: Consort Health Care

Architect: Keppie Architects

Main Contractor: Balfour Morrison JV

Start date: August 1998

Completion date: January 2003



## Great Ormond Street Hospital

As Great Ormond Street Hospital embarks on a 16-year, multi-million pound development programme, Knauf Drywall is providing key products and expertise that will help it stay in the forefront of children's medicine for years to come.

The first phase of the building programme provides new in-patient beds in the Botnar Wing and reduces the pressure on acute beds in the Southwood Building. It will also provide space to accommodate the next phase of the development project.

The dry-lining work, which is being carried out by subcontractor Baris on behalf of the main contractor HBG, involves a range of Knauf Drywall products and some unusual design details.

As well as some curved partition work, there has also been a major requirement to accommodate penetrations for piping, medical gases and other specialised services. Knauf Drywall was also called upon to provide a technical solution to the requirement for fire-wheels and hoses to be mounted in the wall while still achieving the necessary fire rating. The systems used included metal stud partitions, wall liner systems, MF ceilings and Knauf Drywall's purpose-designed Shaftwall system for lift and service shafts.

Knauf Drywall has provided a high level of on-the-spot support to make sure that every aspect of the project runs smoothly. This has included regular site visits, technical support, the approval and underwriting of design detailing, and developing bespoke systems for specialist applications.

Richard Pateman, project manager for HBG: "We have really appreciated the help and support that Knauf Drywall has provided. Knowing that they are there when you need them is a real comfort factor when we are working on some of the more unusual aspects of the project".



### Contract information

Client: Great Ormond Street Hospital for Children NHS Trust

Architect: Ashen Dyer

Main Contractor: HBG

Start date: April 2003

Completion date: September 2005

# HOSPITALS



## Walsgrave Hospital

The Walsgrave Hospital development consolidates the old Coventry and Warwickshire hospitals into one enormous development, 5 storeys high and stretching a quarter of a mile in length. When work started, this was the largest project outside of London.

Knauf Drywall products and systems are being installed throughout the development, which provides a mix of accident & emergency, specialist services and research. The 1212 bed Acute Hospital incorporates 27 theatres including 5 day surgery theatres, whilst a new Clinical Sciences Building provides teaching and research facilities. The completion of the Acute Hospital is scheduled for the summer of 2006, with demolition of the remaining old buildings due in 2007.

The Knauf Drywall Specification Team were involved from an early stage, and used their wide experience of previous PFI schemes to quickly produce a cost-effective and practical specification, engineering out potential problems.

The specification made extensive use of Knauf Soundshield on 70 mm Knauf Metal Studs to provide the thinnest possible severe duty rated partitions with the required acoustic performance. Bespoke security walls were purpose-designed by the Knauf Drywall team, utilising Knauf Soundshield in combination with other durable materials. Two hour compartment walls are catered for with a double layer of Knauf Fireshield. Other Knauf Drywall systems used include Wall Linings, MF Ceilings and specialist Shaftwall.

Drylining contractor Baris of Nottingham is installing Knauf Soundshield on 70 mm stud throughout the Acute Hospital. Terry Whittaker, Project Manager for Skanska, comments:

“Knauf Drywall has been involved with the project from early design stages, providing valuable advice on project specifications and solutions for best value.”



### Contract information

Client: University Hospitals Coventry and Warwickshire NHS Trust

Architect: Nightingales

Main Contractor: Skanska Innisfree JV

Start date: February 2002

Completion date (acute): July 2006



### Knauf Drywall expertise

The Knauf Drywall Specification Team have a wealth of experience in value engineering, specifying and supporting major healthcare projects, with numerous large contracts successfully completed over the past 10 years.

Knauf Drywall's range of purpose-designed products and systems to suit the requirements of the health care sector provide the starting point from which the optimum specification can be developed.

The specification team are able to offer advice and guidance from the very start of the project, at the design stage, right through to providing on-site support to the contractor during the installation phase. This is backed up by an experienced telephone based technical support team, comprehensive literature and an award winning website, [www.knaufdrywall.co.uk/themanual](http://www.knaufdrywall.co.uk/themanual).

Table 10, below, highlights some of the more recent prestigious healthcare projects that the Knauf Drywall Specification Team have been connected with. You can contact Knauf Drywall Technical Services on 01795 416259.

**Table 10 – These are just a few recent examples of the many prestigious health care projects that the Knauf Drywall Specification Team has been involved in**

Project and location	Main contractor	Sub contractor	Project and location	Main contractor	Sub contractor
<b>St Thomas Hospital, Lambeth</b>	Gleeson	Astins	<b>Queen Mary Hospital, London</b>	Bovis	BDL
<b>Edgware Community Hospital</b>	Mowlem	Baris	<b>Royal West Sussex Hospital</b>	Henry Jones	AT Jones
<b>Tiverton Hospital, Devon</b>	Gleeson	Astins	<b>Hinchingbrooke, Cambridgeshire</b>	Kier Eastern	Bee in Line
<b>UCLH, London</b>	Balfour Beatty/AMEC	BDL	<b>Queens Park Hospital, Blackburn</b>	Balfour Beatty	Interstat
<b>Nuffield Orthopaedic Centre, Oxford</b>	Shepherd	Drytech	<b>Nottingham City Hospital</b>	Shepherd	Tellings
<b>Royal Preston Hospital</b>	Shepherd	Interstat	<b>Westview, Tenterden</b>	Costain	Astins
<b>Nuffield Hospital, York</b>	Shepherd	Horbury	<b>Westbrook, Margate</b>	Costain	Astins
<b>Whittington Hospital, London</b>	Mowlem	Astins	<b>Central Middlesex, London</b>	Bouygues	Astins
<b>Havering Hospital, Romford</b>	Bovis	Astins	<b>Newham General Hospital</b>	Laing O'Rourke	Quad

Further information is contained within The Complete Drywall Manual, available online at our award winning website: [www.knaufdrywall.co.uk/themanual](http://www.knaufdrywall.co.uk/themanual) together with a range of interactive tools to aid the specifier and contractor.

#### **Customer Service**

Freephone: 0800 521 050

Freefax: 0800 521 205

E-mail: [cservice@knauf.co.uk](mailto:cservice@knauf.co.uk)

#### **Technical Service**

Tel: 01795 416 259

#### **Literature**

Tel: 08700 613 700

#### **Website**

[www.knaufdrywall.co.uk](http://www.knaufdrywall.co.uk)

#### **Knauf Drywall**

**PO Box 133**

**Sittingbourne**

**Kent ME10 3HW**

**Tel: (01795) 424 499**

**Fax: (01795) 428 651**

#### **Knauf Drywall Factory**

##### **Locations**

Ridham Dock

Sittingbourne

Kent

Queens Road

Immingham

N.E. Lincolnshire

© Copyright Knauf Drywall 2004

The information given in this document is believed to be current and accurate as at the date of publication, but no warranty express or implied is given. Updates will not be automatically issued.

As part of our policy of continuous product development, we reserve the right to revise specifications without notice. The information given in this publication is provided for guidance only and is correct to the best of our knowledge and belief. It is inevitably generalised and users should satisfy themselves as to the suitability for the specific circumstances in which they seek to apply it.