

ASG-System

Aluminum Supported Glass

Glazing System

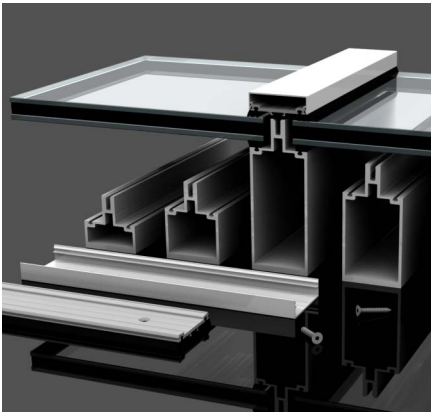

System Components

01. Traditional glazing system using aluminum profiles and gaskets
02. Aluminum is Grade 6061T6
03. Fasteners are typically Grade 304 stainless steel
04. Gaskets are EPDM or silicone compatible rubber
05. Panels can be glass or opaque panel/plate products
06. Novum Structures designs but does not manufacture aluminum supported glass. Novum purchases these items from experienced strategic partners on all continents



Applications

01. Vertical, overhead and sloped glazing
02. Typically the aluminum provides a linear support structure to all edges of the glass
03. Used where flat panels require support along their edges
04. Well suited to simple geometries and conventional angular changes in surface planes

System Attributes

01. Traditional glazing methodology with wide range of off the shelf aesthetics
02. External aesthetic is 2 sided capped, 4 sided capped or flush glazed
03. Glass panels are typically designed using standard manufacturer's tables
04. Width of profile accommodates a lenient glass fit in the design and field
05. Can meet Florida code approval for enclosures
06. Readily available from many global partners
07. Integrates fully with many Novum Structural Systems

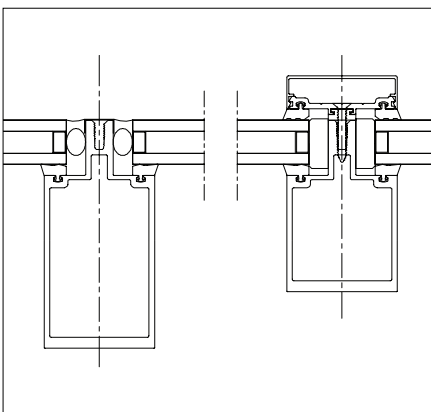

Options/Materials/Finishes

01. Glass can be monolithic, laminated or insulated in any thickness
02. Many glass coatings and frit patterns are available
03. Standard finish and material is clear anodized aluminum
04. Cap plates are aluminum
05. Profile color coating options are available using anodizing, acrylic or Kynar

Front: Cyprus Credit Union, UT
Architect: Gillies Stransky Brems Smith Architects

CCG-System

Corner Clamped Glass

Glazing System

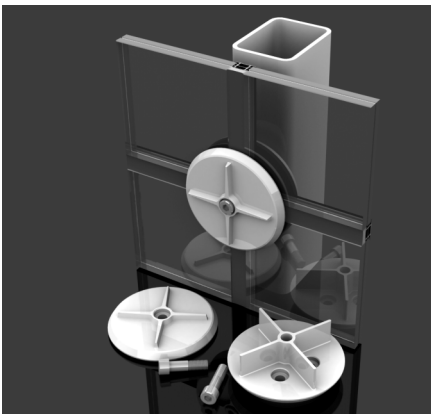

System Components

01. External cover clamp is cast aluminum or stainless steel Grade 304 or 316
02. Fasteners are Grade 316 stainless steel
03. 100% silicone joints comprised of wet silicone and extruded silicone gaskets

Applications

01. Used primarily for vertical and sloped glazing
02. Used where flat glazing panels are supported only at their corners

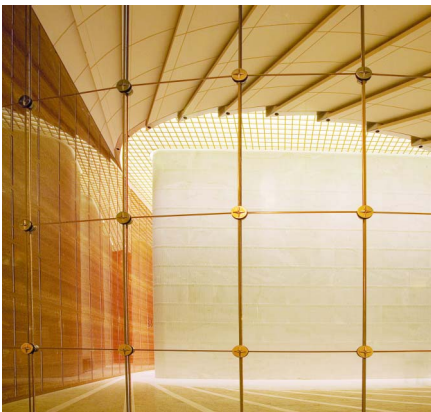

System Attributes

01. Contemporary technology design aesthetic
02. Minimal glass joint widths
03. Nominal interruption of glass surface for maximum transparency
04. 90% plus flush glazed aesthetic
05. Back clamp is designed to interface with a variety of structural systems
06. Ideal for cable nets or to optimize structural supports
07. Free air flow around interior glass surface reduces condensation
08. Glass panels are designed using finite element analysis for maximum safety
09. Panel sizes are limited by applied loading or glass type
10. Clamped fitting is easily installed
11. Easily designed for modest angular changes in surface planes
12. Integrates fully with most other Novum Structural Systems

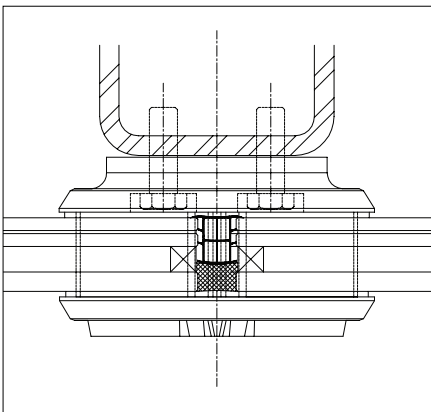

Options/Materials/Finishes

01. Glass can be monolithic, laminated or insulated
02. Glass or panels can be 3/8" to 1-3/4" thick
03. Many glass coatings and frit patterns are available
04. Standard metal finish is cast stainless electro-polished
05. Options include satin finish, bead blasted stainless steel or cast aluminum

ECG-System

Edge Clamped Glass

Glazing System

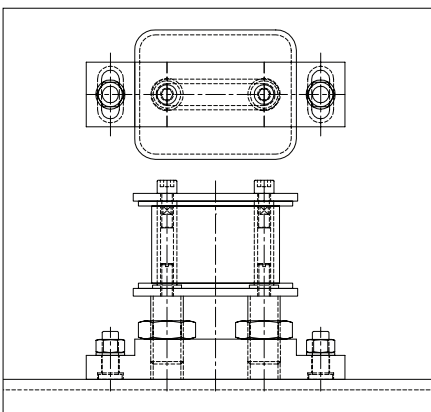
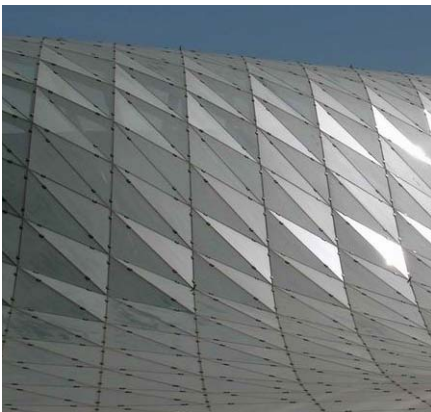
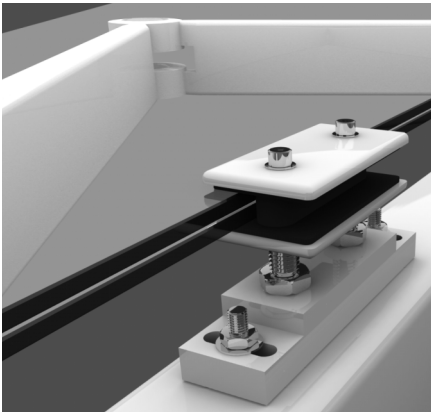

System Components

01. Top cover plate is formed to accept a variety of angles and can be aluminum or Grade 316 stainless steel
02. Fasteners and studs are Grade 316 stainless steel
03. Aluminum cast base and lower clamp
04. Glass/panel spacers are stiff silicone
05. Panels can be glass or opaque stiff panel/plate products
06. 100% silicone joints comprised of wet silicone and extruded silicone gaskets

Applications

01. Vertical, overhead and sloped glazing
02. Used where flat panels are to be supported primarily along their edges

System Attributes

01. Contemporary design aesthetic where the glass appears to "float"
02. Extremely well suited to angular changes in surface planes
03. Minimal glass joint widths
04. Panel can be 2, 3 or 4 sided support
05. Nominal interruption of glass surface for maximum transparency
06. 90% plus flush glazed aesthetic
07. Free air flow around the interior glass surface reduces condensation
08. Clamped fitting is easily adjustable and ideal for fast installation
09. Standard clamp finishes are stocked for fast track scheduling
10. Glass panels are designed using finite element analysis for maximum safety
11. Large panel sizes and loads can be accommodated by increasing the number of panel clamps
12. Integrates fully with all Novum Structural Systems

Options/Materials/Finishes

01. Glass can be monolithic, laminated or insulated
02. Glass or panels can be 3/8" to 1-3/4" thick
03. Many glass coatings and frit patterns are available
04. Standard finish is silver metallic, fluoro carbon coated aluminum
05. Cap plate options include stainless steel #4, #8 or bead blasted
06. Other color choices are available as an option

Front: Rail Central, UT
Architect: EMA Architects, LLC

LSG-System

Linear Supported Glass

Glazing System

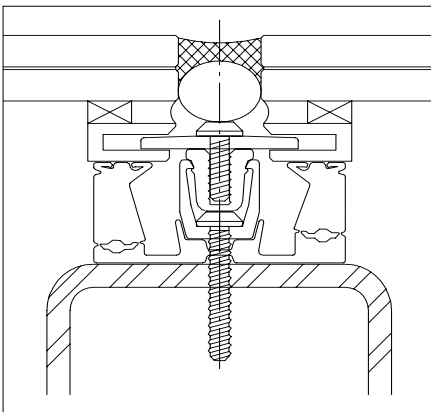
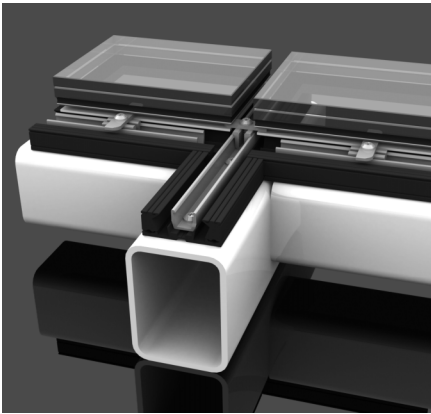

System Components

01. Novum EPDM setting gasket with butyl sealant provides a secondary water barrier
02. Cap plates are optional and can be aluminum or Grade 316 stainless steel
03. Internal aluminum extruded fastening channel for weather capping and/or dead load
04. Glass panels mechanically attach to the substructure with hidden Grade 304 stainless toggle fasteners
05. Silicone joints comprised of wet silicone and extruded silicone gaskets

Applications

01. Vertical, overhead and sloped glazing
02. Used where direct attachment to a structure is desirable
03. Used where flat panels can be continuously supported along their edges

System Attributes

01. Better transparency as the contemporary skin system can be directly integrated to the primary structure thereby decreasing layering effects
02. Minimal glass joint widths
03. Insulated glass can be attached with special inset in the spacer or can utilize a back channel
04. Panels can be 2, 3 or 4 sided support
05. The 2 sided support option allows glass to glass joints in one direction
06. Architectural options include a flush glazed aesthetic or 2 or 4 sided decorative caps
07. Glass panels are designed using finite element analysis for maximum safety
08. Large panel sizes and loads can be accommodated by increasing the number of toggle fasteners
09. Well suited to minor angular changes in surface planes
10. Integrates fully with most Novum Structural Systems and is typically used with Architecturally Exposed Steel, Block Knoten or Beam to Beam Systems

Options/Materials/Finishes

01. Glass can be monolithic, laminated or insulated in varied thicknesses
02. Many glass coatings and frit patterns are available
03. Standard EPDM gasket is black with dark gray as an option
04. Cap plates are powder coated aluminum as standard. Options include stainless steel #4, #8 or bead blasted

Front: Overture Hall Performing Arts Center, WI
Architect: Pelli Clarke Pelli Architects

PSG-System

Point Supported Glass

Glazing System

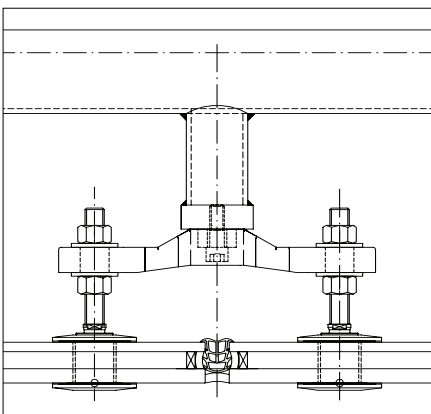
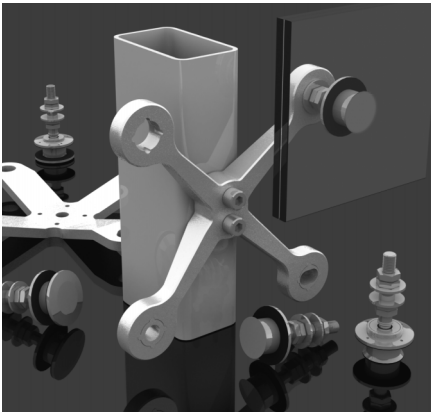

System Components

01. Grade 316 stainless steel glass fixing bolts can be rotational (rotules) or fixed
02. Wide variety of cast or plate connecting arms in stainless, mild steel or aluminum
03. Panels can be glass or opaque stiff panel/plate products
04. 100% silicone joints comprised of wet silicone and extruded silicone gaskets

Applications

01. Vertical, overhead, suspended and sloped glazing
02. Where highly optimized structures are to be glazed

System Attributes

01. Very clean technology design aesthetic
02. Minimal glass joint widths with no interruption of glass edges
03. Nominal interruption of glass surface for maximum transparency
04. Free air flow around the interior glass surface reduces condensation
05. Glass panels are designed using finite element analysis for maximum safety
06. Rotational fittings enable larger panel sizes and accommodate bigger structural movements
07. Individual panels are statically determinate
08. Many items are stocked for fast track scheduling
09. Carries Florida product approval
10. System applications are designed by Novum's in-house engineers
11. Integrates fully with all Novum Structural Systems

Options/Materials/Finishes

01. Glass can be monolithic, laminated or insulated in any thickness
02. Panels can be fixed countersunk flush surface or have raised button fixings
03. Many glass coatings and frit patterns are available
04. Stainless arms can be electro-polished, satin or bead blasted
05. Mild steel arms are painted and/or galvanized

Front: Sea-Tac International Airport, WA
Architect: Fentress Bradburn Architects, Ltd.