



FREE UK DELIVERY



SITE SURVEYS



10 YEAR GUARANTEE



INSTALLATION SERVICE



MADE IN BRITAIN

# GAS ASSISTED TWO TIER CYCLE RACK



THE  
**BIKE STORAGE**  
COMPANY

**0800 246 1723**

[www.thebikestoragecompany.co.uk](http://www.thebikestoragecompany.co.uk)

[hello@thebikestoragecompany.co.uk](mailto:hello@thebikestoragecompany.co.uk)

306 Harbour Yard, London, SW10 0XD

# GAS ASSISTED TWO TIER CYCLE RACK

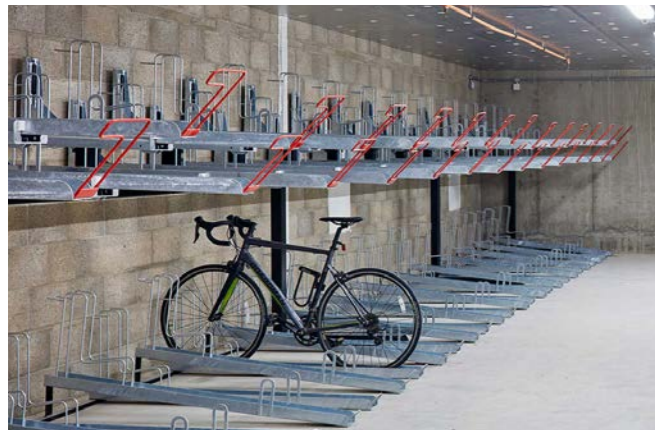

## Hot Dipped Galvanised Handles

Hot Dipped Galvanised handles to BS EN ISO 1461:2022 for optimal durability. If you're looking to create a more personalised bike storage zone we can provide Framework Powder Coating to any RAL colour.



## EasyGrip Handles

Access to the second tier of the rack is aided by the EasyGrip handles, lightweight steel and gas-assisted mechanisms that take the weight of the bike during the mounting and unmounting process.

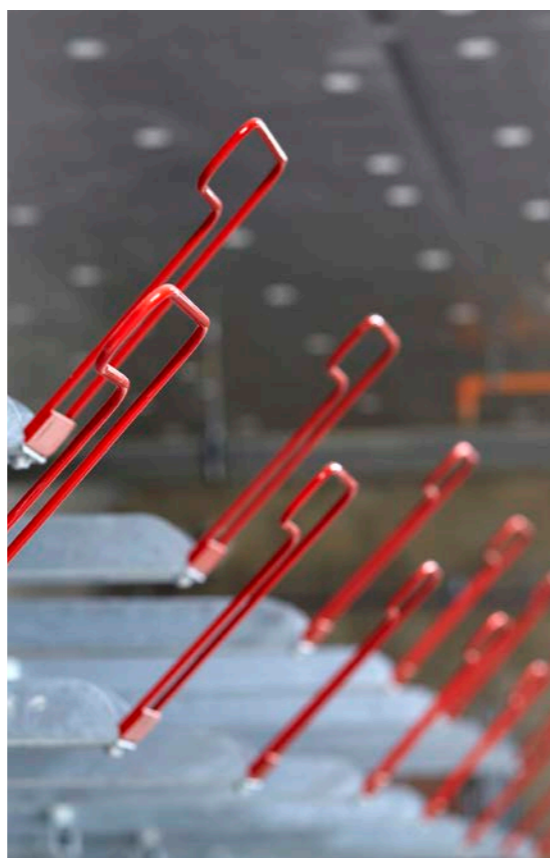

## TOP

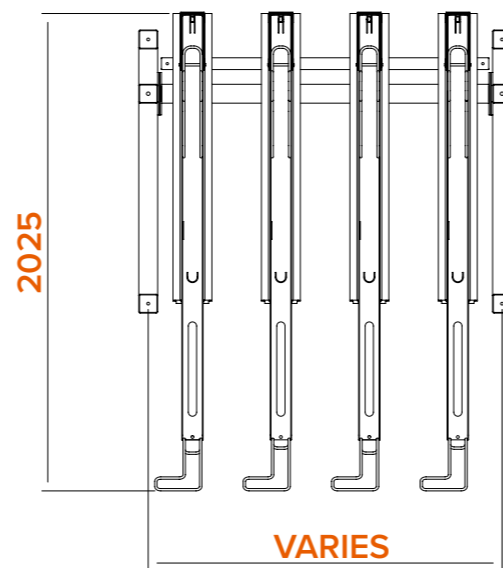

## SIDE

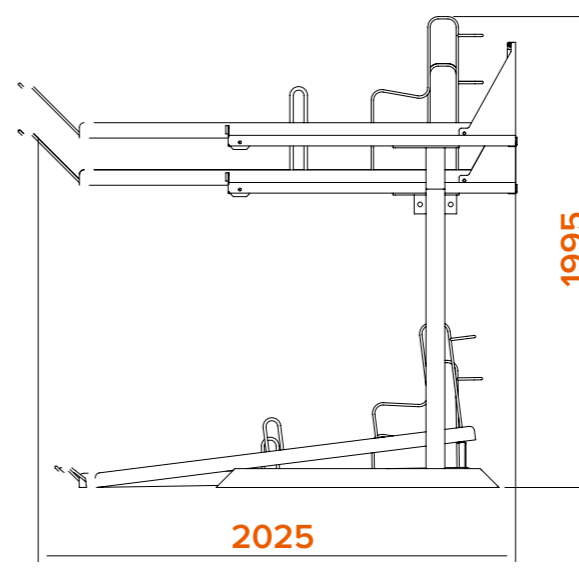

## FRONT

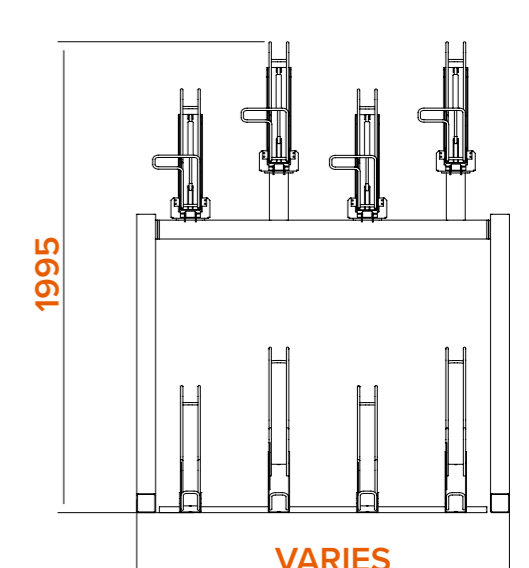

The Gas Assisted Two Tier Bike Rack provides convenient high-density bicycle parking alongside the ultimate user-friendly experience. Each upper-level rack has a tamper-proof gas strut integrated at the back; this assistance eliminates all strain from the bike loading process and has been rated up to 30 kg. The bike's wheels and frame can be secured to the locking point, ensuring a high-security cycle rack. Gas Strut tested to over 30,000 users. Supports any bike with a maximum tyre width of 64mm. This rack can help you achieve BREEAM Compliant status.

## FEATURES

- Free Delivery
- UK Manufactured
- Tested to over 30,000 users
- Gas-assisted lifted mechanism
- Minimum height required is 2500mm
- Single or back-to-back versions are available
- Hot Dipped Galvanised to BS EN ISO 1461:2011
- Full site visit and layout design provided free of charge
- Code for Sustainable Homes compliant and BREEAM Compliant
- Allows for both the wheels and the frame to be locked to the rack
- Manufactured against your dimensions and room layout at no extra cost
- 375mm spacing between racks and a staggered height design allows for space utilisation and ease of access

## OPTIONAL EXTRA

- EasyGrip red handle
- Powder coating (excluding inner channel)
- Intergrated back-to-back channel arrangement
- Lower level channels (rack is provided as standard with Sheffield Stands for lower level)



## INSTALL REQUIREMENTS

- Rack to wall aisle width: 1635mm
- Rack to rack aisle width: 1635mm
- Minimum ceiling height: 2500mm
- Centre of rack leg to wall tolerance: 300mm

## SPACING REQUIREMENTS

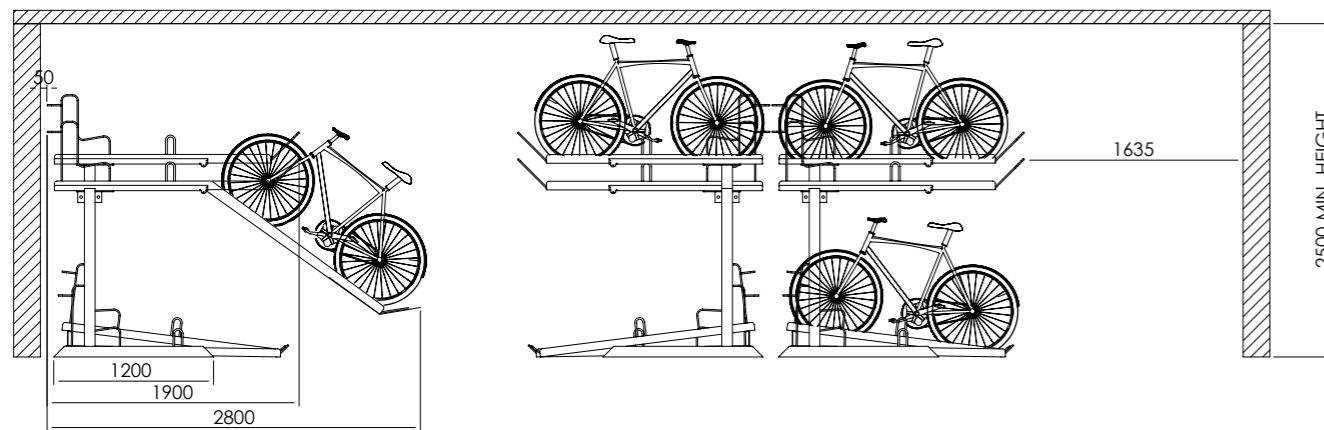

TOP

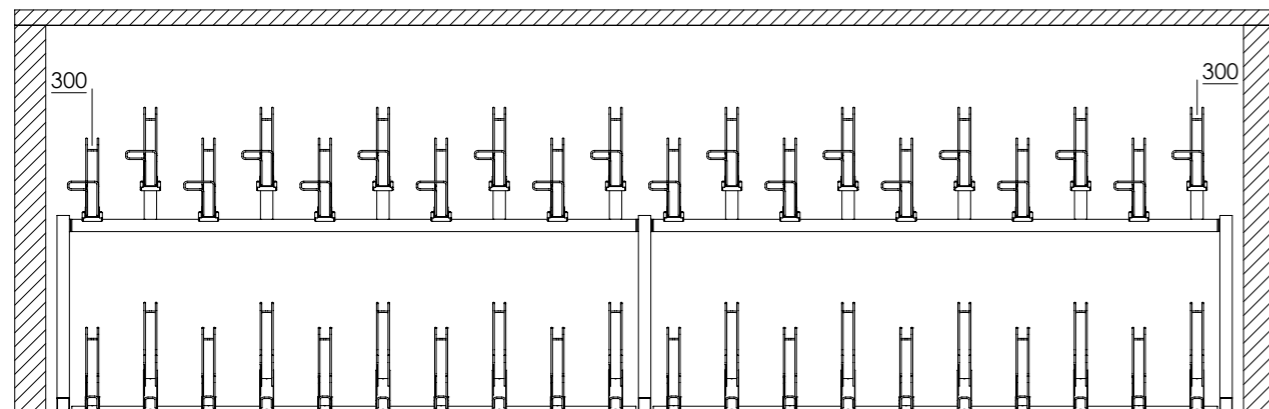

FRONT

## LAYOUT 1

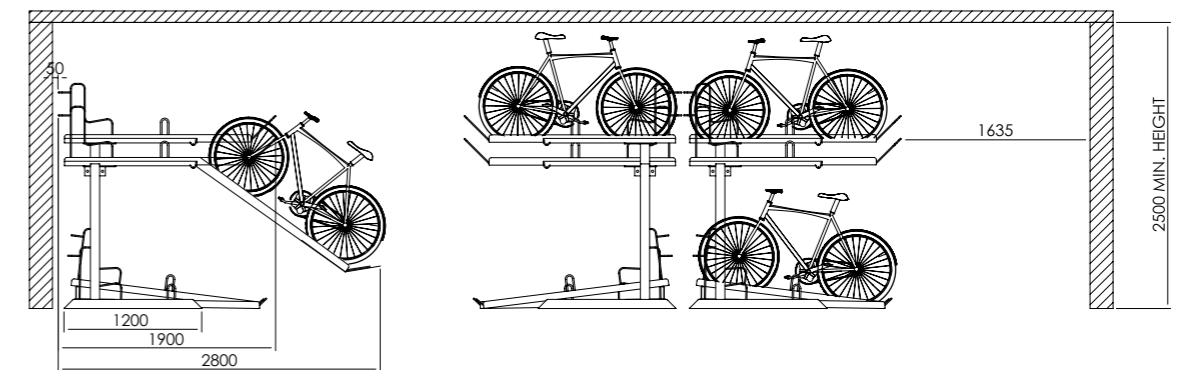
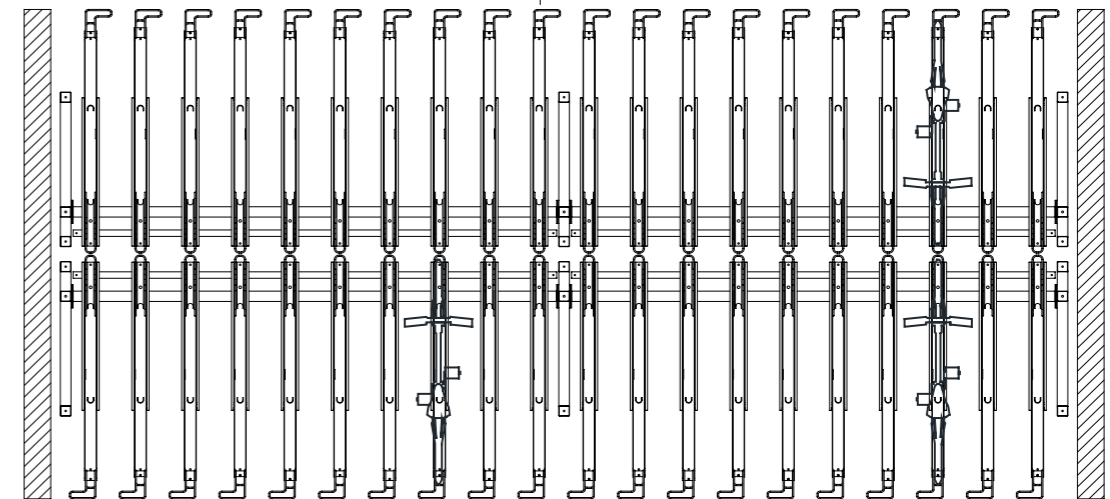
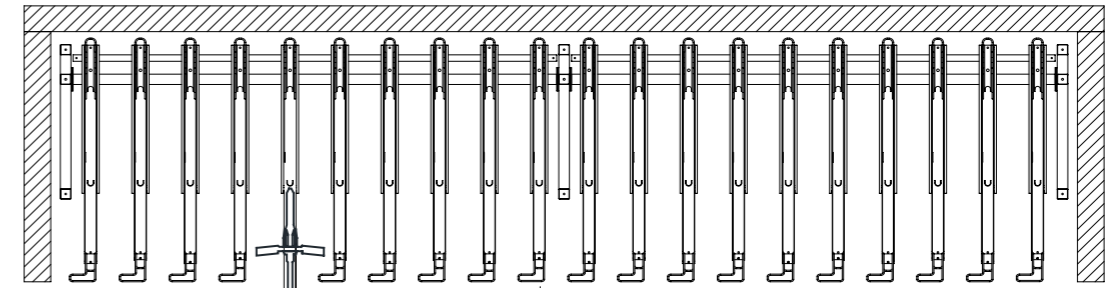

SIDE

## LAYOUT 2

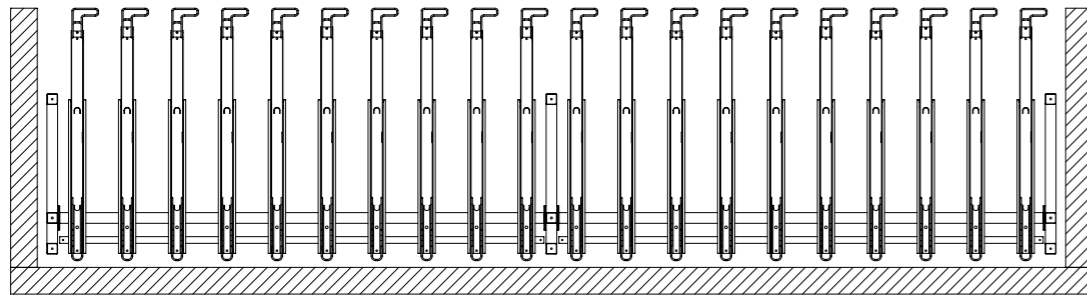
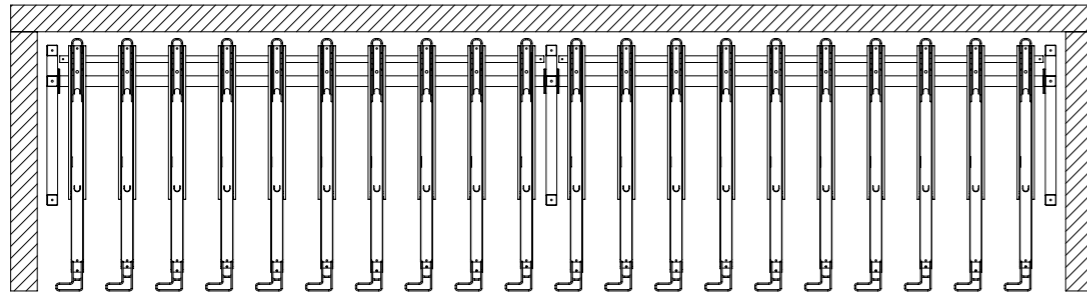

### TOP

## LAYOUT 3

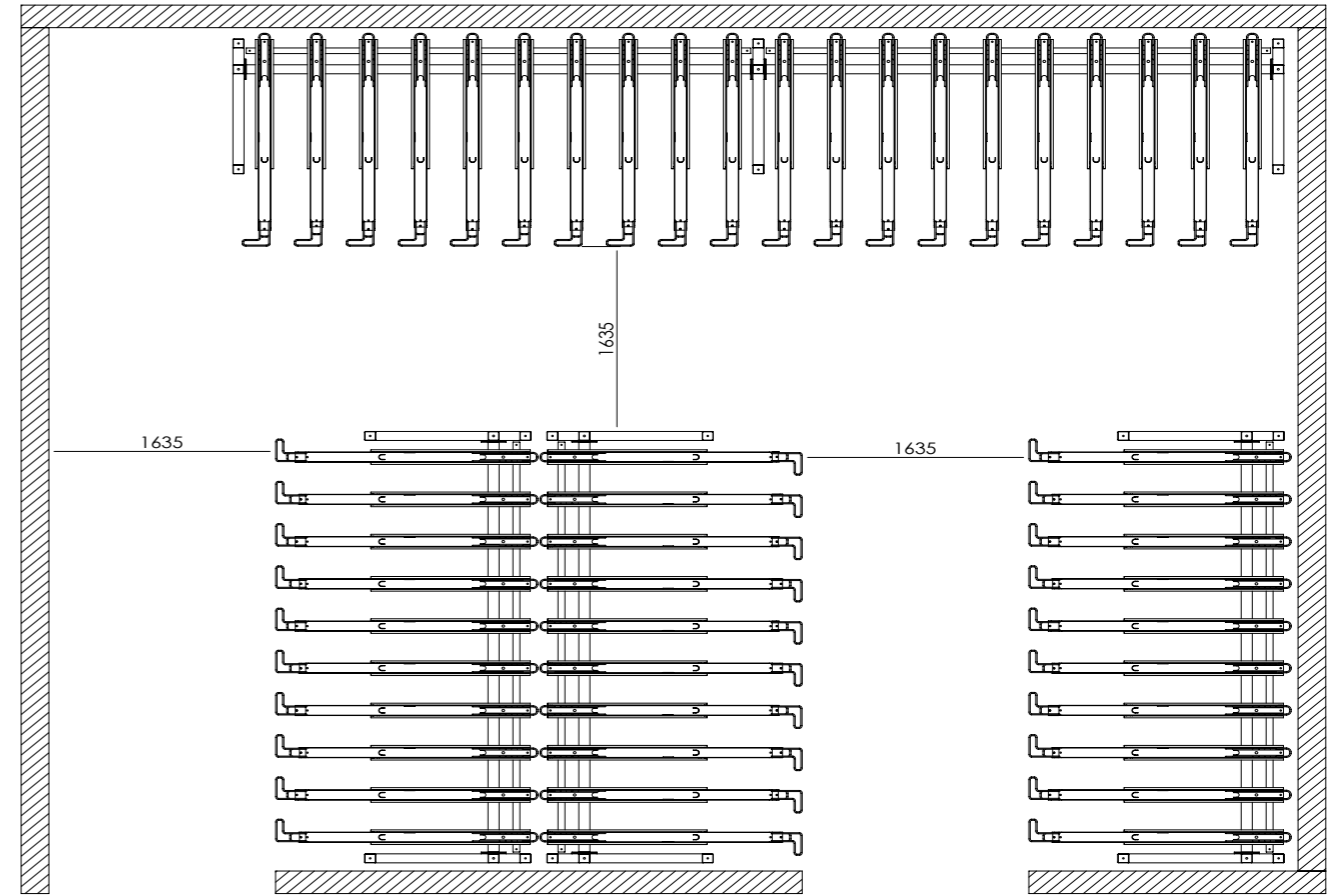

### TOP

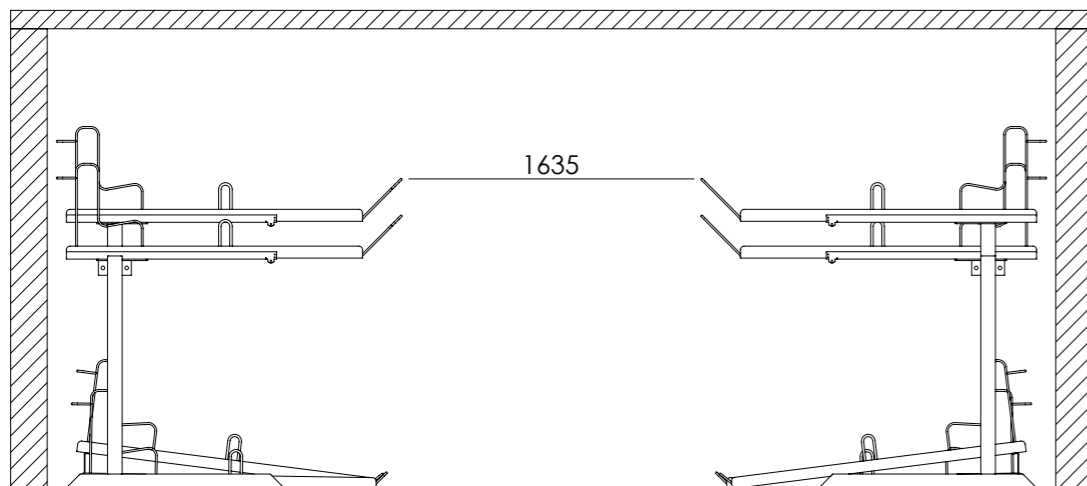

### SIDE

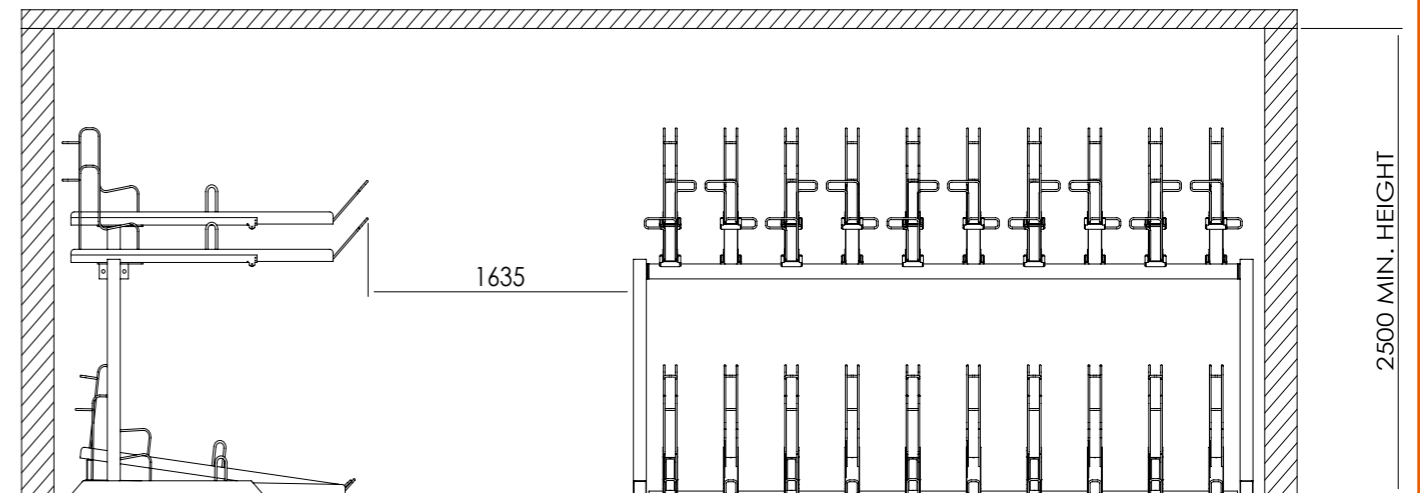

### SIDE