

Step 12: In-Service Testing

12.1 Purpose

The purpose of in-service tests is to regularly monitor and record the performance of the thermostatic mixing valve. Deterioration in performance can indicate the need for service work on the valve and/or the water supplies.

12.2 Procedure

Using the same measuring equipment or equipment to the same specification as used in the commissioning of the valve, adjust the temperature of the mixed water in accordance with the manufacturer's instructions and the requirement of the application.

Carry out the following sequence:

- record the temperature of the hot and cold water supplies
- record the temperature of the mixed water at the largest draw-off flow rate
- record the temperature of the mixed water at a smaller draw-off flowrate, which shall be measured

If the mixed water temperature has changed significantly from the previous test results (e.g. >1 K), record the change and before re-adjusting the mixed water temperature check:

- that any in-line or integral strainers are clean
- any in-line or integral check valves or other anti-back siphonage devices are in good working order
- any isolating valves are fully open

With an acceptable mixed water temperature, complete the following procedure:

- record the temperature of the hot and cold water supplies
- record the temperature of the mixed water at the largest draw-off flow rate
- record the temperature of the mixed water at a smaller draw-off flow rate, which shall be measured
- isolate the cold water supply to the mixing valve and monitor the mixed water temperature

e) record the maximum temperature achieved as a result of (d) and the final stabilised temperature

f) record the equipment, thermometer etc. used for the measurements

If at step (e) the final mixed water temperature is greater than the values in Table 1 and / or the maximum temperature exceeds the corresponding value from the previous results by more than about 2 K, the need for service work is indicated.

NOTE: In-service tests should be carried out with a frequency, which identifies a need for service work before an unsafe water temperature can result. In the absence of any other instruction or guidance, the procedure described in Annex F of D 08 may be used - Annex F of D 08 (informative)

Step 13: Frequency of In-Service Tests

13.1 General

In the absence of any other instruction or guidance on the means of determining the appropriate frequency of in-service testing, the following procedure may be used:

- 6-8 weeks after commissioning carry out the "In-Service Tests"
- 12-15 weeks after commissioning carry out the "In Service Tests"

The results of the above tests may present several possibilities:

- If no significant changes (e.g. 1 K) in mixed water temperatures are recorded between commissioning and 6 to 8 week testing, or between commissioning and 12-15 week testing the next in-service test can be deferred to 24 to 28 weeks after commissioning.
- If small changes (e.g. 1 to 2 K) in mixed water temperatures are recorded in only one of these periods, necessitating adjustment of the mixed water temperature, then the next in-service test can be deferred to 24 to 28 weeks after commissioning.
- If small changes (e.g. 1 to 2 K) in mixed water temperatures are recorded in both of these periods, necessitating adjustment of the mixed water temperature, then the next in-service test should be carried out at 18 to 21 weeks after commissioning.

- If significant changes (e.g. > 2 K) in mixed water temperatures are recorded in either of these periods, necessitating service work, then the next in-service test should be carried out at 18 to 21 weeks after commissioning.

The general principle to be observed after the first 2 or 3 in-service tests is that the intervals of future tests should be set to those which previous tests have shown can be achieved with no more than a small change in mixed water temperature.

13.2 Operation

The tap is lever operated. Moving the lever clockwise will increase the water temperature till the maximum set by the TMV is attained.

13.3 Fault Finding

TAP WILL NOT OPERATE AT ALL

- Check water is turned on.
- Check hot / cold feed is connected correctly
- Check filters for debris.

13.4 General Cleaning

IMPORTANT: Do not use abrasive materials or cleaners. Only use soap and water or nonabrasive cleaners.

13.5 Warranty & Support

Warranty

The tap kit is guaranteed for 5 years from purchase against defective material and assembly.

Support

For technical support please visit our technical pages at www.dartvalley.co.uk, contact us by e-mail at techsupport@dartvalley.co.uk or alternatively call us direct on 01803 529021.

AquariTherm Tap (Manual)

Installation, Maintenance & Operating Instructions

MT04-001 AquariTherm Tap - Manual Standard Kit

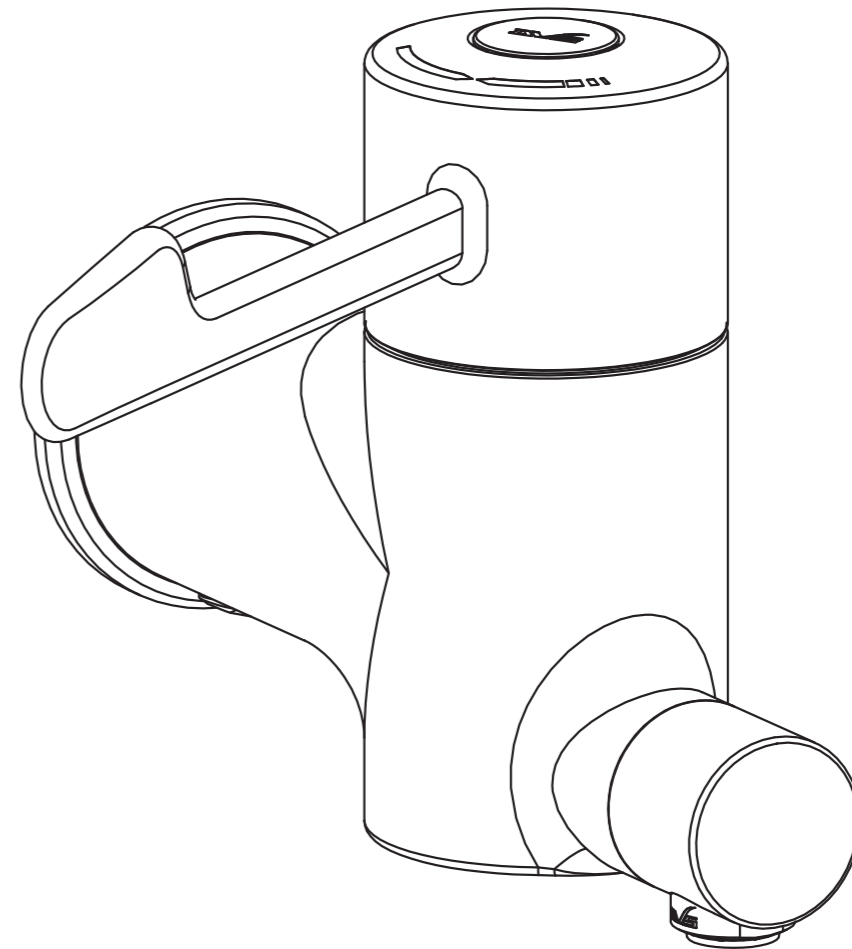

Step 1: Safety First

These instructions relate to the installation of the **MT04-001 AquariTherm Tap (Manual)** only. Any external or 'add-on' parts will be supplied with separate instructions.

Appropriate personal protective equipment must be worn when installing, calibrating and commissioning this product.

It is recommended that any plumbing is carried out by a qualified plumber.

This is a sophisticated product which must be installed correctly to perform correctly.

If the appliance is used by persons (including children) with reduced physical, sensory or mental capabilities, or lack of experience and knowledge, they must be given adequate supervision or instruction concerning use of the appliance by a person responsible for their safety.

Children should be supervised to ensure that they do not play with the product.



IMPORTANT: Please read these instructions carefully and follow each stage in order!

Step 2: Kit Contents

Your kit will include the following parts*:

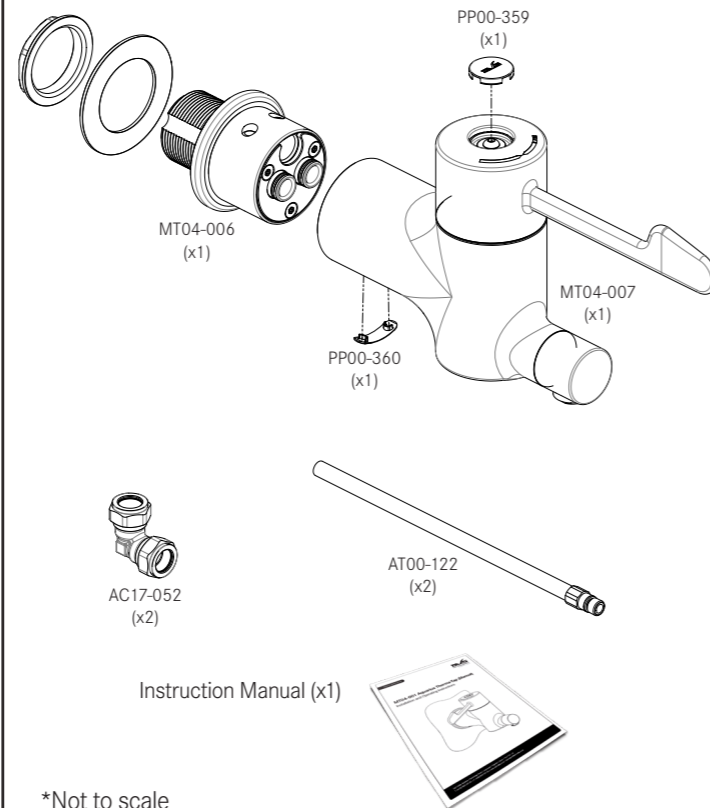

*Not to scale

Step 3: Introduction

The tap incorporates a thermoregulating cartridge to ensure users of consistent water temperatures.

The tap is suitable, without modification, for all types of installation, including pump boosted systems and mains pressure.

The valve has been designed and manufactured to comply with NHS D08 requirements for washbasin applications up to 41°C high and high pressure designations.

The valve has been independently tested and approved as a Type 3 valve under the TMV3 scheme with the HP-WE designation of use.

Table 1: Technical Specification / Condition of Use for Type 3 valves

Maximum Static Pressure	10 Bar
Dynamic Pressure	1 to 5 Bar
Hot Supply Temperature	55-65 °C
Cold Supply Temperature	5-20 °C
Minimum Temperature Differential (Mix to Hot) for Fail-Safe	10 °C
Temperature Stability	+/- 2 °C

NOTE: Balanced pressures are desirable, but must be maintained within the ranges above.

Table 2: Mixed Water Temperature Approvals

Code	HP-WE
Application	Washbasin
Mixed Water Temperature (at point of discharge)	41 °C
Operating Pressure	High Pressure (1-5 Bar)

NOTE: For washbasins, washing under running water is assumed. The fitting of isolation valves is required as close as is practicable to the water supply inlets of the AquariTherm. Non-return valves and strainers are to be fitted internally- see fig.13.

Step 10 (continued): Maintenance and Servicing

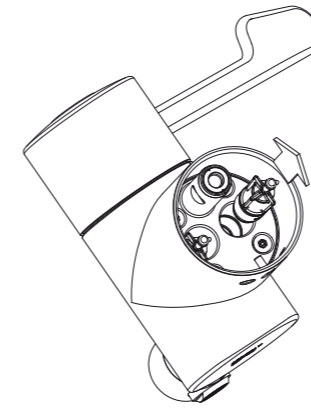

Fig 12

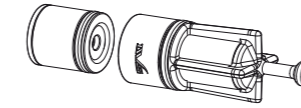

Fig 13

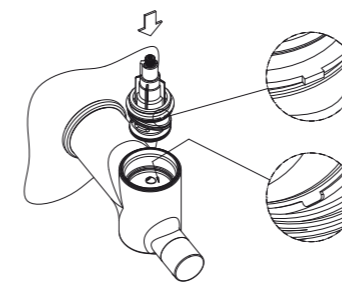

Fig 14

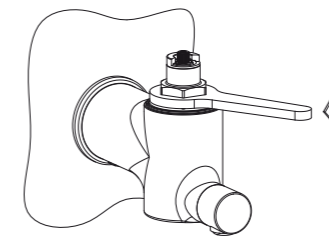

Fig 15

10.2 Thermostatic Cartridge

To remove the thermostatic cartridge, remove screw cover and unscrew the retaining screw and remove penny washer, handle and limit ring (Fig 9). Unscrew the cartridge retaining nut and pull the cartridge out. Clean or replace cartridge as necessary. Be sure to re-fit the cartridge with its locating lug pointing forwards (Fig 14). Refit the cartridge retaining nut and tighten to 35Nm (Fig 15). Replace the handle only, and reactivate the cold and hot water supplies

Turn the handle until the water just stops flowing. Remove handle and position the limit ring on the cartridge retaining nut, as shown (Fig 16).

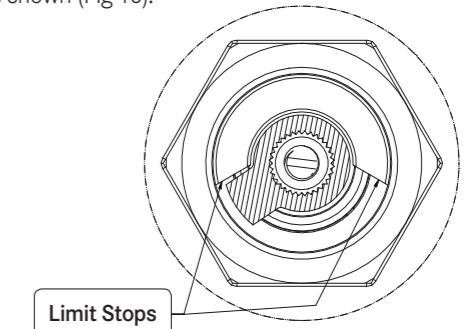

Fig 16

Refit the handle and position such that the tap operation from fully closed to fully open is symmetrical and follow steps 8.

Secure the handle with retainer screw and penny washer. Refit screw cover so that the logo is square to the handle arm.

Step 11: Method for Commissioning Thermostatic Cartridge

11.1 Purpose

Since the installed supply conditions are likely to be different from those applied in the laboratory tests it is appropriate, at commissioning, to carry out some simple checks and tests on each mixing valve to provide a performance reference point for future in-service tests.

11.2 Procedure

Check that:

- the designation of the thermostatic mixing valve matches the intended application
- the supply pressures are within the range of operating pressures for the designation of the valve
- the supply temperatures are within the range permitted for the valve and by guidance information on the prevention of legionella etc.

Adjust the temperature of the mixed water in accordance with the manufacturer's instructions and the requirement of the application and then carry out the following sequence:

- record the temperature of the hot and cold water supplies
- record the temperature of the mixed water at the largest draw-off flow rate

- record the temperature of the mixed water at a smaller draw-off flow rate, which shall be measured
- isolate the cold water supply to the mixing valve and monitor the mixed water temperature
- record the maximum temperature achieved as a result of (d) and the final stabilised temperature

NOTE: The final stabilised mixed water temperature should not exceed the values in Table 3

- record the equipment, thermometer etc. used for the measurements

Table 3: Guide to maximum stabilised temperatures recorded during site tests

Application	Mixed Water Temperature
Washbasin	41 °C

Step 9: TMV Temperature Calibration and Setup

Turn handle fully clockwise to its closed position.

Carefully remove screw cover, retainer screw and penny washer, only (Fig 9).

NOTE: Do not remove the handle.

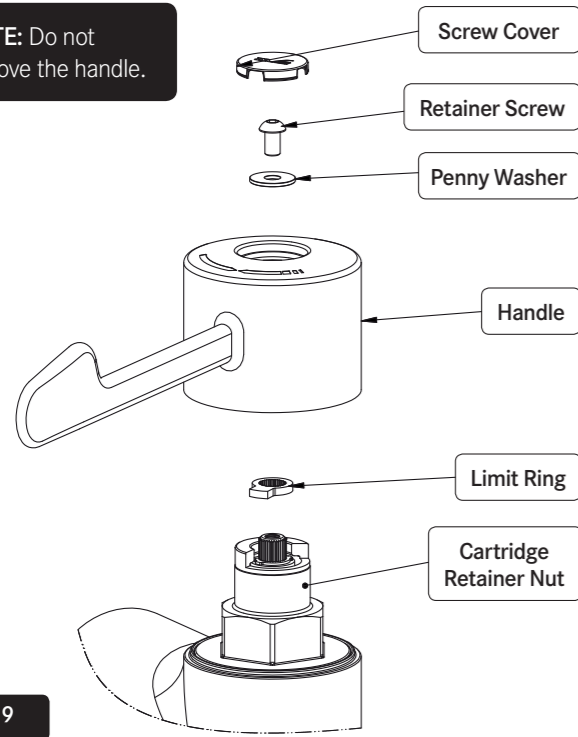

Fig 9

Remove the spindle plug (in middle of spindle head) (Fig 10).

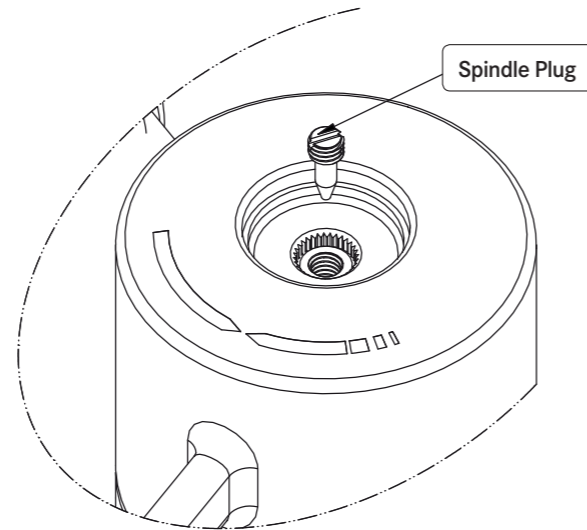

Fig 10

- Using a 3mm slotted screwdriver, insert through the hole and locate the setting screw (Fig 11).
- Turn the setting screw clockwise to reduce the temperature and counter clockwise to increase the temperature.
- Only adjust by a small amount, a 1/4 turn in either direction should be sufficient to reach the desired temperature.
- When desired temperature has been set, replace the spindle plug.

Refit the penny washer, retainer screw and the screw cover.

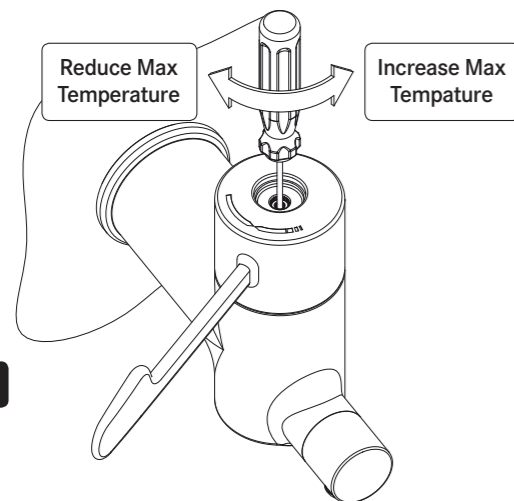

Fig 11

Step 10: Maintenance and Servicing

The thermostatic cartridge should give many years of trouble-free service, but in the event of failure or where routine maintenance is required servicing is straightforward.

10.1 Filter and Check Valve

To service the internal filter and check valve the body needs to be removed from the spigot.

Ensure handle is turned fully clockwise to the closed position (Fig 7).

Using a 6mm slotted screw driver isolate the hot water supply by turning the integrated isolation valve 90 clockwise (Fig 7.1).

Follow the same procedure for the cold supply.

Remove the retainer screw (Fig. 6 and 6.1).

The main body can now be removed to enable servicing of the filter and check valve.

The filter cartridges (Fig 13) can be removed from the body of the tap (Fig 12).

The filters can be removed and replaced. Service kits are available contact sales@dartvalley.co.uk or call (01803) 529021.

Step 4: Drilling and Preparation

IMPORTANT: Plumbing compound should not be used to seal the pipework as oils leaching from the compound will prevent the TMV from functioning correctly.

We recommend the fitting of local hot & cold isolation valves prior to the tap if not already fitted.

Turn off hot & cold water supply. Cut pipework using a suitable plumbers cutting tool, remove any sharp edges, locate isolation valves on to pipes and tighten, make sure the new valves are in the off position then turn the water back on, test for any leaks.

Using a bucket open each valve individually and purge water through into the bucket this will remove any dirt left in the pipework.

Refer to current HTM guidelines for tap positioning information, also ensure adequate access is given under the Spigot to operate integrated isolation valves.

Mark and drill a 50mm diameter hole in the wall panel where the tap is to be located and a 4.5mm hole for the anti-rotation pin (Fig. 1).

IMPORTANT: The tap is supplied with an anti-rotation pin. Failure to fit the pin will result in void of warranty.

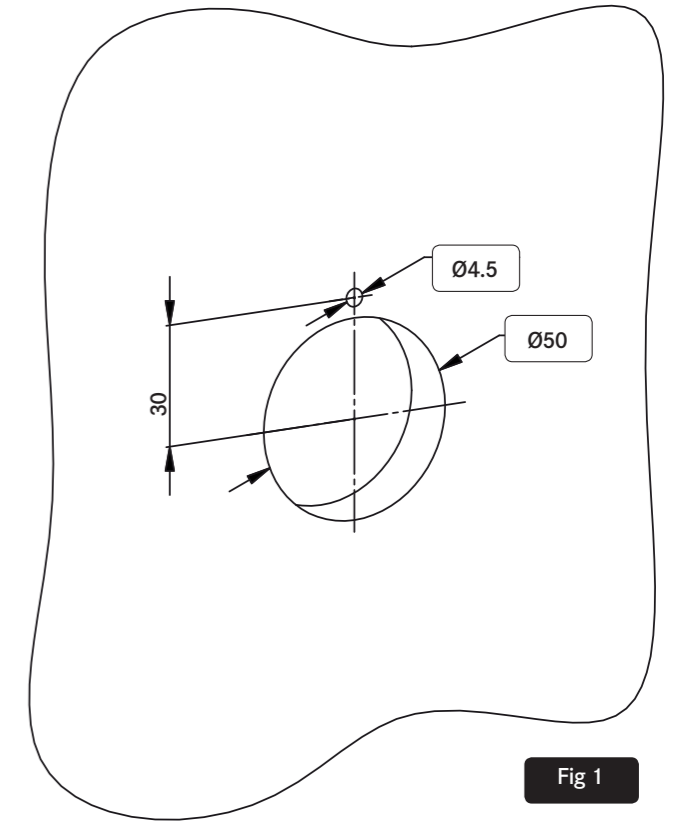
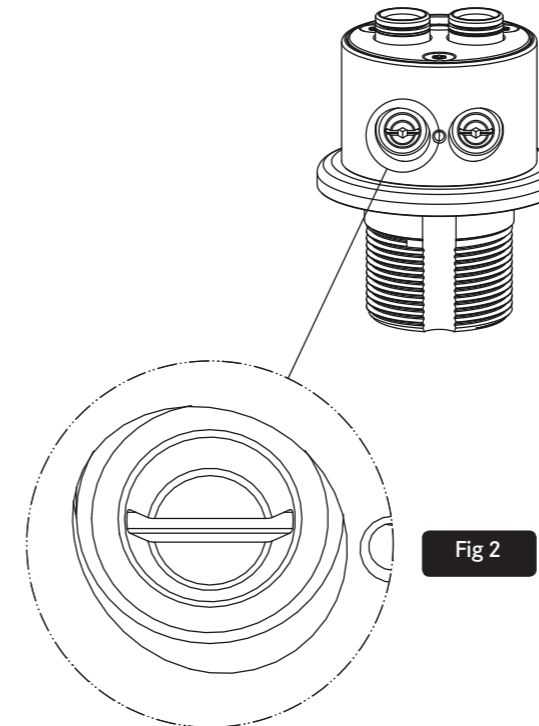

Fig 1

Step 5: Mounting the Spigot and Plumbing

Check ball valves on wall spigot are in the closed position as Fig. 2.



Mount the spigot to the wall surface and secure with the nut and washer provided (Fig 3).

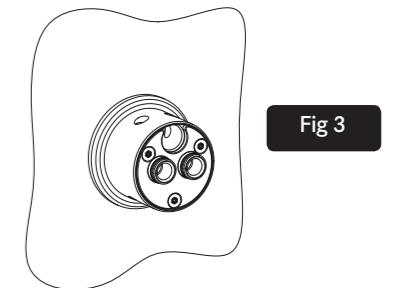

Connect the HOT and COLD water supply to the spigot using the copper tails provided with the kit (Fig 4) taking care to ensure the HOT and COLD supply are connected correctly as indicated by the coloured indicators. It is important that all pipework should be thoroughly flushed through before connecting the tap.

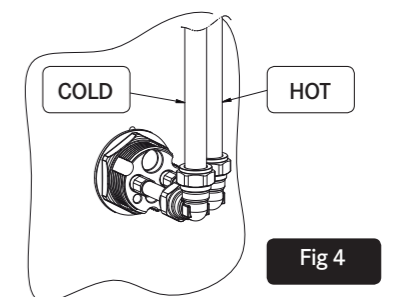

Step 6: Mounting the Tap

Fit main body to wall spigot (Fig. 5). Ensure body is fully located over the spigot.

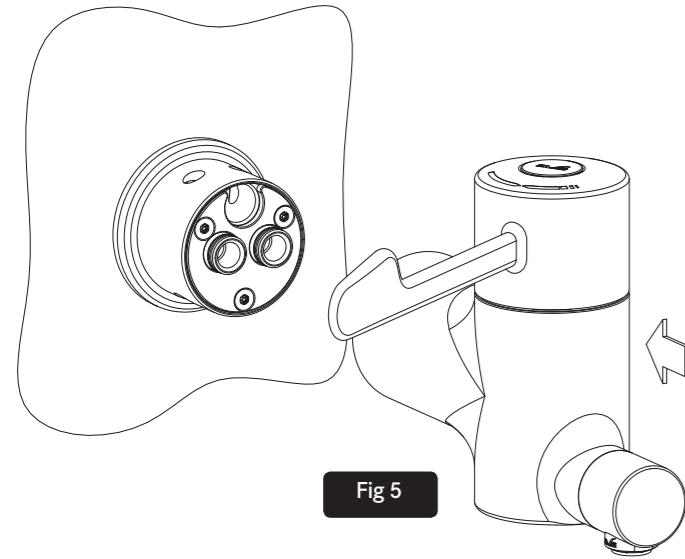
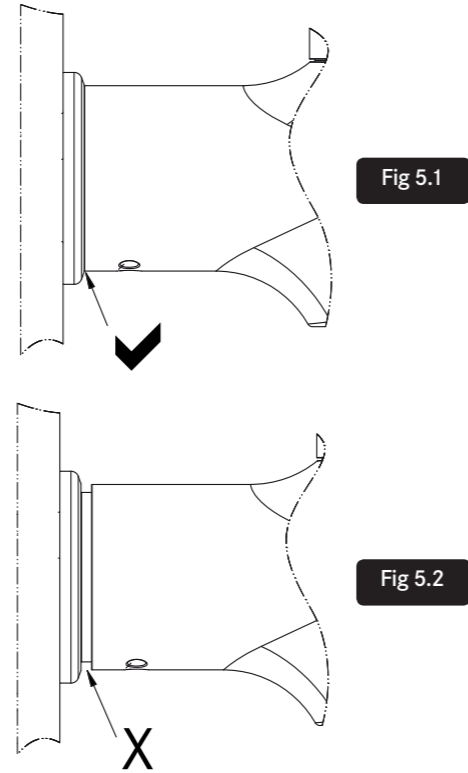
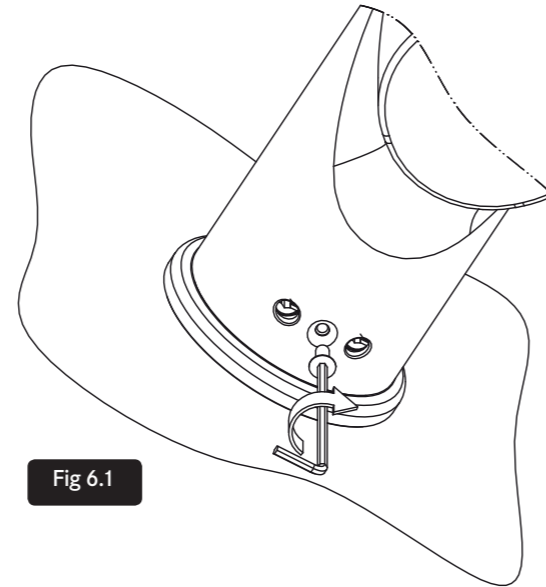
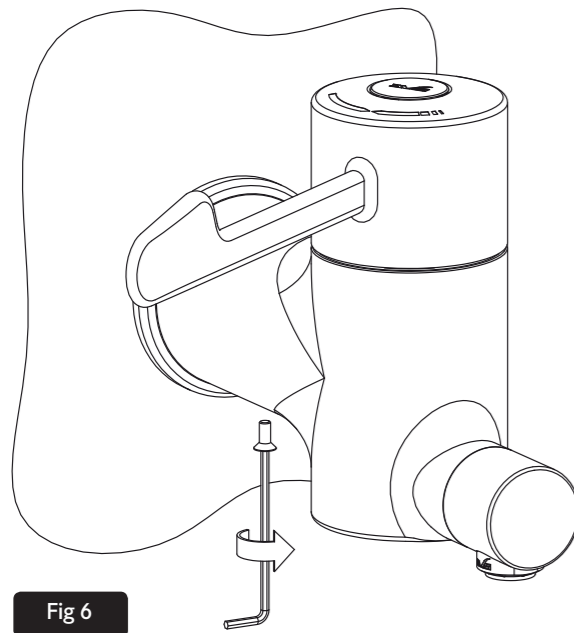

Fig 5.1 shows the body correctly located whereas the body has not been fully engaged in Fig 5.2.



Using a 2.5mm Allen key fit retainer screw (Fig. 6 and 6.1).



Step 7: Activating the Water Supply

Ensure handle is turned fully clockwise to the closed position (Fig 7).

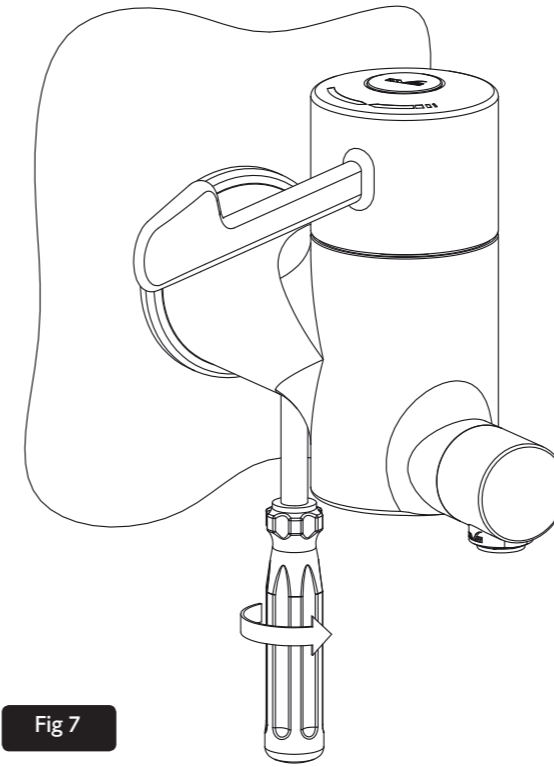

Using a 6mm slotted screw driver the cold water supply is activated by turning the integrated water isolation valve 90° counter clockwise (Fig 7.1). Follow the same procedure for the hot supply.

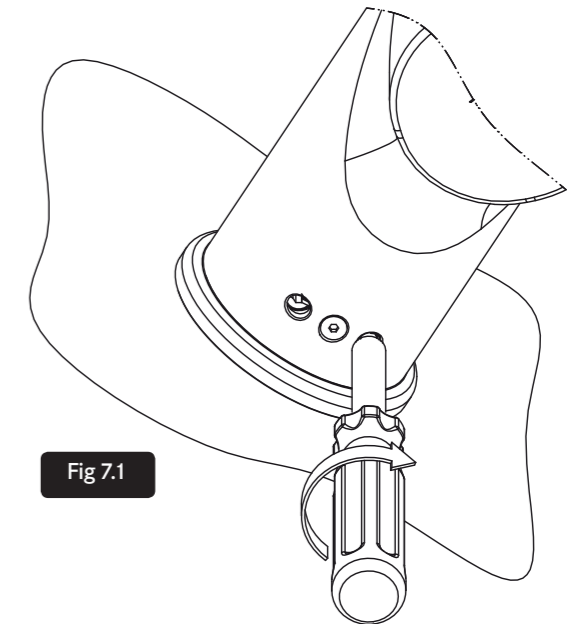

Step 8: Checking the TMV Temperature

To test the TMV, turn handle counter clockwise to its fully open position and check water temperature using a thermometer (Fig 8).

The temperature should be set at 41°C.

If the temperature is outside the range 40-42°C the TMV should be calibrated, as per Step 9.

