

# AQUARIUS WM STRAIGHT

## Brushed with PEX Hose

### AT02-001

The Aquarius range incorporate simple and modern design, with the latest electronic functionality.

Sensor operated for maximum hygiene and efficiency. 5 litres per minute integrated flow control. (Standard 5LPM, Other flow rates available)  
Automatic purge function, Sensor range adjustment, Wave on/wave off function, Anti Vandal and Lock Out functions, Chlorination function.

Single mixed feed connection by PEX lined hose (15mm connection). External TMV required. Brushed finish.

**Requires a Station kit to operate. Station kits available in Single Station Battery or Mains Single Station, 2 Station or 3 Station for multiple connections. Refer to Station kit Data sheets.**

PRODUCT NUMBER	
AT02-001	Brushed WM Straight no touch tap
TECHNICAL DATA	
Type of tap	Aquarius WM Straight
Material	316 Stainless Steel
Surface finish	Brushed
Gross weight	1.05 kg
Type of operation	No Touch Sensor
Type of mounting	Wall mounted
Type of mixing	Additional TMV may be required
Automatic purge	Yes* - Default: OFF Options: 3, 6, 12, 24, 36 & 48 hours Default 1 min*
Purge run time	Options: OFF, 30 secs, 1, 2, 4 & 8 mins 120mm / 150mm
Spout projection / Total tap length	1.00 bar (Lower pressure station kits available) 5LPM (Other flow rates available) Yes* - Default: 2 secs
Minimum flow pressure	Options: 2, 5, 10, 15, 20, 30 secs 15mm PEX hose
Volume flow rate at 3 bar	Yes
Adjustable run time	Default OFF* Options: OFF, 4, 6, 8 & 10 operations Yes* - Default 2 mins Options: 1, 2, 3, 4, 5, 10, 20 & 30 mins
Water connection	Single Battery: AT00-001 Single Mains: AT00-002 - Other options available. Contact DVS.
Anti-Vandal function	1-10 Bar (For Low / High pressure, Contact DVS.)
Lock out function	60 °C
Chlorination function	¾" BSP
Battery or mains station kit	Up to 30mm with flange nut
Working pressure	
Max working temperature	
Fixing	
Fixing length	

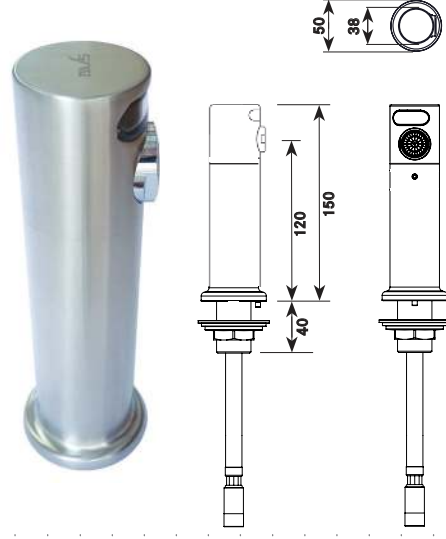

ALL DIMENSIONS IN MM



Last Updated: 2015-09-22, Dart Valley Systems



\* (Set By Handheld Programmer)

# AQUARIUS WM STRAIGHT

## Brushed with Copper Tails

### AT02-002

The Aquarius range incorporate simple and modern design, with the latest electronic functionality.

Sensor operated for maximum hygiene and efficiency. 5 litres per minute integrated flow control. (Standard 5LPM, Other flow rates available)

Automatic purge function, Sensor range adjustment, Wave on/wave off function, Anti Vandal and Lock Out functions, Chlorination function.

Single mixed feed connection by Copper tail (10mm). External TMV required. Brushed finish.

**Requires a Station kit to operate. Station kits available in Single Station Battery or Mains Single Station, 2 Station or 3 Station for multiple connections. Refer to Station kit Data sheets.**

#### PRODUCT NUMBER

AT02-002      Brushed      WM Straight no touch tap

#### TECHNICAL DATA

Type of tap	Aquarius WM Straight
Material	316 Stainless Steel
Surface finish	Brushed
Gross weight	1.05 kg
Type of operation	No Touch Sensor
Type of mounting	Wall mounted
Type of mixing	Additional TMV may be required
Automatic purge	Yes* - Default: OFF Options: 3, 6, 12, 24, 36 & 48 hours Default 1 min*
Purge run time	Options: OFF, 30 secs, 1, 2, 4 & 8 mins 120mm / 150mm
Spout projection / Total tap length	1.00 bar (Lower pressure station kits available)
Minimum flow pressure	5LPM (Other flow rates available)
Volume flow rate at 3 bar	Yes* - Default: 2 secs
Adjustable run time	Options: 2, 5, 10, 15, 20, 30 secs 10mm Copper tails
Water connection	Yes
Anti-Vandal function	Default OFF*
Lock out function	Options: OFF, 4, 6, 8 & 10 operations Yes* - Default 2 mins
Chlorination function	Options: 1, 2, 3, 4, 5, 10, 20 & 30 mins
Battery or mains station kit	Single Battery: AT00-001 Single Mains: AT00-002 - Other options available. Contact DVS.
Working pressure	1-10 Bar (For Low / High pressure, Contact DVS.)
Max working temperature	60 °C
Fixing	¾" BSP
Fixing length	Up to 30mm with flange nut

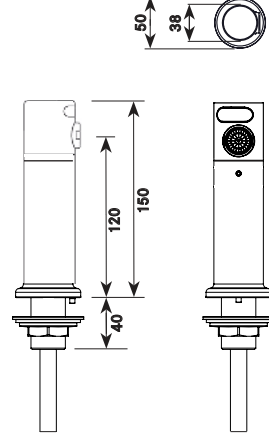

ALL DIMENSIONS IN MM

Last Updated: 2015-09-22, Dart Valley Systems



\* (Set By Handheld Programmer)

# AQUARIUS WM STRAIGHT

## Brushed with Stainless Tails

### AT02-003

The Aquarius range incorporate simple and modern design, with the latest electronic functionality.

Sensor operated for maximum hygiene and efficiency. 5 litres per minute integrated flow control. (Standard 5LPM, Other flow rates available)

Automatic purge function, Sensor range adjustment, Wave on/wave off function, Anti Vandal and Lock Out functions, Chlorination function.

Single mixed feed connection by Stainless tail (10mm). External TMV required. Brushed finish.

**Requires a Station kit to operate. Station kits available in Single Station Battery or Mains Single Station, 2 Station or 3 Station for multiple connections. Refer to Station kit Data sheets.**

#### PRODUCT NUMBER

AT02-003	Brushed	WM Straight no touch tap
----------	---------	--------------------------

#### TECHNICAL DATA

Type of tap	Aquarius WM Straight	
Material	316 Stainless Steel	
Surface finish	Brushed	
Gross weight	1.05 kg	
Type of operation	No Touch Sensor	
Type of mounting	Wall mounted	
Type of mixing	Additional TMV may be required	
Automatic purge	Yes* - Default: OFF Options: 3, 6, 12, 24, 36 & 48 hours Default 1 min*	
Purge run time	Options: OFF, 30 secs, 1, 2, 4 & 8 mins 120mm / 150mm	
Spout projection / Total tap length	1.00 bar (Lower pressure station kits available)	
Minimum flow pressure	5LPM (Other flow rates available)	
Volume flow rate at 3 bar	Yes* - Default: 2 secs	
Adjustable run time	Options: 2, 5, 10, 15, 20, 30 secs 10mm Stainless tails	
Water connection	Yes	
Anti-Vandal function	Default OFF*	
Lock out function	Options: OFF, 4, 6, 8 & 10 operations Yes* - Default 2 mins	
Chlorination function	Options: 1, 2, 3, 4, 5, 10, 20 & 30 mins	
Battery or mains station kit	Single Battery: AT00-001 Single Mains: AT00-002 - Other options available. Contact DVS.	
Working pressure	1-10 Bar (For Low / High pressure, Contact DVS.)	
Max working temperature	60 °C	
Fixing	¾" BSP	
Fixing length	Up to 30mm with flange nut	

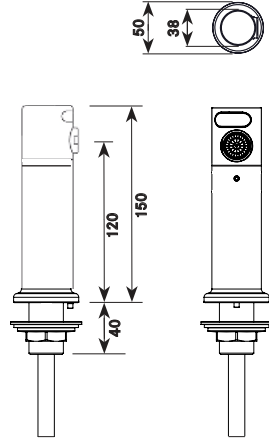

ALL DIMENSIONS IN MM



Last Updated: 2015-09-22. Dart Valley Systems



\* (Set By Handheld Programmer)

# AQUARIUS WM STRAIGHT

Polished with PEX Hose

## AT02-005

The Aquarius range incorporate simple and modern design, with the latest electronic functionality.

Sensor operated for maximum hygiene and efficiency. 5 litres per minute integrated flow control. (Standard 5LPM, Other flow rates available)

Automatic purge function, Sensor range adjustment, Wave on/wave off function, Anti Vandal and Lock Out functions, Chlorination function.

Single mixed feed connection by PEX lined hose (15mm connection). External TMV required. Polished finish.

**Requires a Station kit to operate. Station kits available in Single Station Battery or Mains Single Station, 2 Station or 3 Station for multiple connections. Refer to Station kit Data sheets.**

### PRODUCT NUMBER

AT02-005	Polished	WM Straight no touch tap
----------	----------	--------------------------

### TECHNICAL DATA

Type of tap	Aquarius WM Straight
Material	316 Stainless Steel
Surface finish	Polished
Gross weight	1.05 kg
Type of operation	No Touch Sensor
Type of mounting	Wall mounted
Type of mixing	Additional TMV may be required
Automatic purge	Yes* - Default: OFF Options: 3, 6, 12, 24, 36 & 48 hours Default 1 min*
Purge run time	Options: OFF, 30 secs, 1, 2, 4 & 8 mins 120mm / 150mm
Spout projection / Total tap length	1.00 bar (Lower pressure station kits available)
Minimum flow pressure	5LPM (Other flow rates available)
Volume flow rate at 3 bar	Yes* - Default: 2 secs
Adjustable run time	Options: 2, 5, 10, 15, 20, 30 secs 15mm PEX hose
Water connection	Yes
Anti-Vandal function	Default OFF*
Lock out function	Options: OFF, 4, 6, 8 & 10 operations Yes* - Default 2 mins
Chlorination function	Options: 1, 2, 3, 4, 5, 10, 20 & 30 mins
Battery or mains station kit	Single Battery: AT00-001 Single Mains: AT00-002 - Other options available. Contact DVS.
Working pressure	1-10 Bar (For Low / High pressure, Contact DVS.)
Max working temperature	60°C
Fixing	¾" BSP
Fixing length	Up to 30mm with flange nut

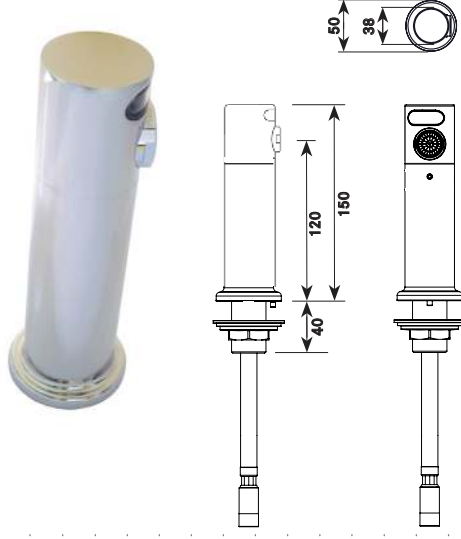

Last Updated: 2015-09-22, Dart Valley Systems



\* (Set By Handheld Programmer)

# AQUARIUS WM STRAIGHT

Polished with Copper Tails

## AT02-006

The Aquarius range incorporate simple and modern design, with the latest electronic functionality.

Sensor operated for maximum hygiene and efficiency. 5 litres per minute integrated flow control. (Standard 5LPM, Other flow rates available)  
Automatic purge function, Sensor range adjustment, Wave on/wave off function, Anti Vandal and Lock Out functions, Chlorination function.

Single mixed feed connection by Copper tail (10mm). External TMV required.  
Polished finish.

**Requires a Station kit to operate. Station kits available in Single Station Battery or Mains Single Station, 2 Station or 3 Station for multiple connections. Refer to Station kit Data sheets.**

### PRODUCT NUMBER

AT02-006	Polished	WM Straight no touch tap
----------	----------	--------------------------

### TECHNICAL DATA

Type of tap	Aquarius WM Straight	
Material	316 Stainless Steel	
Surface finish	Polished	
Gross weight	1.05 kg	
Type of operation	No Touch Sensor	
Type of mounting	Wall mounted	
Type of mixing	Additional TMV may be required	
Automatic purge	Yes* - Default: OFF Options: 3, 6, 12, 24, 36 & 48 hours Default 1 min*	
Purge run time	Options: OFF, 30 secs, 1, 2, 4 & 8 mins 120mm / 150mm	
Spout projection / Total tap length	1.00 bar (Lower pressure station kits available) 5LPM (Other flow rates available) Yes* - Default: 2 secs	
Minimum flow pressure	Options: 2, 5, 10, 15, 20, 30 secs 10mm Copper tails	
Volume flow rate at 3 bar	Yes	
Adjustable run time	Default OFF*	
Water connection	Options: OFF, 4, 6, 8 & 10 operations Yes* - Default 2 mins	
Anti-Vandal function	Options: 1, 2, 3, 4, 5, 10, 20 & 30 mins	
Lock out function	Single Battery: AT00-001 Single Mains: AT00-002 - Other options available. Contact DVS.	
Chlorination function	1-10 Bar (For Low / High pressure, Contact DVS.) 60 °C	
Battery or mains station kit	3/4" BSP Up to 30mm with flange nut	
Working pressure		
Max working temperature		
Fixing		
Fixing length		

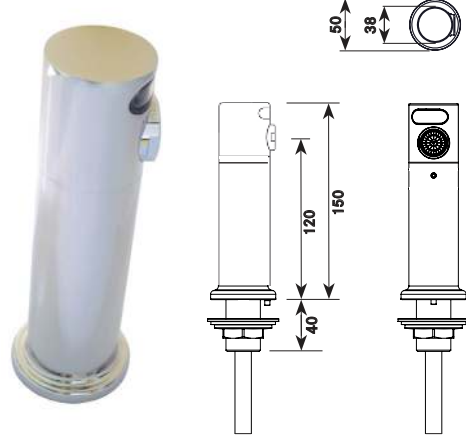

ALL DIMENSIONS IN MM



Last Updated: 2015-08-20, Dart Valley Systems



\* (Set By Handheld Programmer)

# AQUARIUS WM STRAIGHT

## Brushed with PEX Hose

### AT02-011

The Aquarius range incorporate simple and modern design, with the latest electronic functionality.

Sensor operated for maximum hygiene and efficiency. 5 litres per minute integrated flow control. (Standard 5LPM, Other flow rates available)

Automatic purge function, Sensor range adjustment, Wave on/wave off function, Anti Vandal and Lock Out functions, Chlorination function.

Single mixed feed connection by PEX lined hose (15mm connection). External TMV required. Brushed finish.

**Requires a Station kit to operate. Station kits available in Single Station Battery or Mains Single Station, 2 Station or 3 Station for multiple connections. Refer to Station kit Data sheets.**

PRODUCT NUMBER	
AT02-011	Brushed WM Straight no touch tap
TECHNICAL DATA	
Type of tap	Aquarius WM Straight
Material	316 Stainless Steel
Surface finish	Brushed
Gross weight	1.15 kg
Type of operation	No Touch Sensor
Type of mounting	Wall mounted
Type of mixing	Additional TMV may be required
Automatic purge	Yes* - Default: OFF Options: 3, 6, 12, 24, 36 & 48 hours Default 1 min*
Purge run time	Options: OFF, 30 secs, 1, 2, 4 & 8 mins 170mm / 200mm
Spout projection / Total tap length	1.00 bar (Lower pressure station kits available)
Minimum flow pressure	5LPM (Other flow rates available)
Volume flow rate at 3 bar	Yes* - Default: 2 secs
Adjustable run time	Options: 2, 5, 10, 15, 20, 30 secs 15mm PEX hose
Water connection	Yes
Anti-Vandal function	Default OFF*
Lock out function	Options: OFF, 4, 6, 8 & 10 operations Yes* - Default 2 mins
Chlorination function	Options: 1, 2, 3, 4, 5, 10, 20 & 30 mins
Battery or mains station kit	Single Battery: AT00-001 Single Mains: AT00-002 - Other options available. Contact DVS.
Working pressure	1-10 Bar (For Low / High pressure, Contact DVS.)
Max working temperature	60 °C
Fixing	¾" BSP
Fixing length	Up to 30mm with flange nut

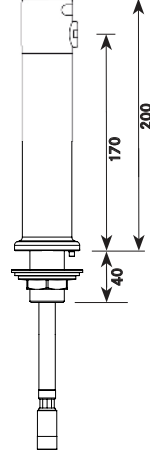

ALL DIMENSIONS IN MM

Last Updated: 2015-09-25, Dart Valley Systems



\* (Set By Handheld Programmer)

# AQUARIUS WM STRAIGHT

## Brushed with Copper Tails

### AT02-012

The Aquarius range incorporate simple and modern design, with the latest electronic functionality.

Sensor operated for maximum hygiene and efficiency. 5 litres per minute integrated flow control. (Standard 5LPM, Other flow rates available)

Automatic purge function, Sensor range adjustment, Wave on/wave off function, Anti Vandal and Lock Out functions, Chlorination function.

Single mixed feed connection by Copper tail (10mm). External TMV required. Brushed finish.

**Requires a Station kit to operate. Station kits available in Single Station Battery or Mains Single Station, 2 Station or 3 Station for multiple connections. Refer to Station kit Data sheets.**

PRODUCT NUMBER	
AT02-012	Brushed WM Straight no touch tap
TECHNICAL DATA	
Type of tap	Aquarius WM Straight
Material	316 Stainless Steel
Surface finish	Brushed
Gross weight	1.15 kg
Type of operation	No Touch Sensor
Type of mounting	Wall mounted
Type of mixing	Additional TMV may be required
Automatic purge	Yes* - Default: OFF Options: 3, 6, 12, 24, 36 & 48 hours Default 1 min*
Purge run time	Options: OFF, 30 secs, 1, 2, 4 & 8 mins 170mm / 200mm
Spout projection / Total tap length	1.00 bar (Lower pressure station kits available)
Minimum flow pressure	5LPM (Other flow rates available)
Volume flow rate at 3 bar	Yes* - Default: 2 secs
Adjustable run time	Options: 2, 5, 10, 15, 20, 30 secs 10mm Copper tails
Water connection	Yes
Anti-Vandal function	Default OFF*
Lock out function	Options: OFF, 4, 6, 8 & 10 operations Yes* - Default 2 mins
Chlorination function	Options: 1, 2, 3, 4, 5, 10, 20 & 30 mins
Battery or mains station kit	Single Battery: AT00-001 Single Mains: AT00-002 - Other options available. Contact DVS.
Working pressure	1-10 Bar (For Low / High pressure, Contact DVS.)
Max working temperature	60 °C
Fixing	¾" BSP
Fixing length	Up to 30mm with flange nut

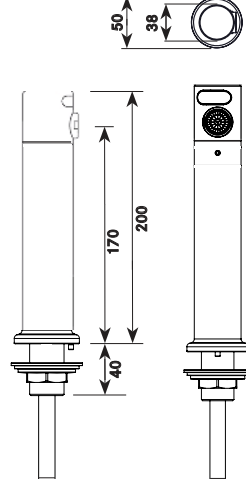

ALL DIMENSIONS IN MM



Last Updated: 2015-09-25, Dart Valley Systems



\* (Set By Handheld Programmer)

# AQUARIUS WM STRAIGHT

Brushed with Stainless Steel Tails

## AT02-013

The Aquarius range incorporate simple and modern design, with the latest electronic functionality.

Sensor operated for maximum hygiene and efficiency. 5 litres per minute integrated flow control. (Standard 5LPM, Other flow rates available)

Automatic purge function, Sensor range adjustment, Wave on/wave off function, Anti Vandal and Lock Out functions, Chlorination function.

Single mixed feed connection by 316 Stainless Steel tail (10mm). External TMV required. Brushed finish.

**Requires a Station kit to operate. Station kits available in Single Station Battery or Mains Single Station, 2 Station or 3 Station for multiple connections. Refer to Station kit Data sheets.**

### PRODUCT NUMBER

AT02-013	Brushed	WM Straight no touch tap
----------	---------	--------------------------

### TECHNICAL DATA

Type of tap	Aquarius WM Straight
Material	316 Stainless Steel
Surface finish	Brushed
Gross weight	1.15 kg
Type of operation	No Touch Sensor
Type of mounting	Wall mounted
Type of mixing	Additional TMV may be required
Automatic purge	Yes* - Default: OFF Options: 3, 6, 12, 24, 36 & 48 hours
Purge run time	Default 1 min* Options: OFF, 30 secs, 1, 2, 4 & 8 mins
Spout projection / Total tap length	170mm / 200mm
Minimum flow pressure	1.00 bar (Lower pressure station kits available)
Volume flow rate at 3 bar	5LPM (Other flow rates available)
Adjustable run time	Yes* - Default: 2 secs Options: 2, 5, 10, 15, 20, 30 secs
Water connection	10mm 316 Stainless Steel tail
Anti-Vandal function	Yes
Lock out function	Default OFF* Options: OFF, 4, 6, 8 & 10 operations
Chlorination function	Yes* - Default 2 mins Options: 1, 2, 3, 4, 5, 10, 20 & 30 mins
Battery or mains station kit	Single Battery: AT00-001 Single Mains: AT00-002 - Other options available. Contact DVS.
Working pressure	1-10 Bar (For Low / High pressure, Contact DVS.)
Max working temperature	60°C
Fixing	¾" BSP
Fixing length	Up to 30mm with flange nut

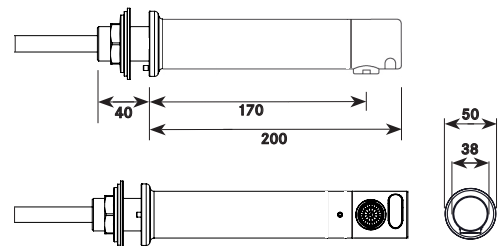

ALL DIMENSIONS IN MM

Last Updated: 2019-08-06, Dart Valley Systems



\* (Set By Handheld Programmer)



# AQUARIUS WM STRAIGHT

Polished with PEX Hose

## AT02-015

The Aquarius range incorporate simple and modern design, with the latest electronic functionality.

Sensor operated for maximum hygiene and efficiency. 5 litres per minute integrated flow control. (Standard 5LPM, Other flow rates available)  
Automatic purge function, Sensor range adjustment, Wave on/ wave off function, Anti Vandal and Lock Out functions, Chlorination function.  
Single mixed feed connection by PEX lined hose (15mm connection). External TMV required. Polished finish.

**Requires a Station kit to operate. Station kits available in Single Station Battery or Mains Single Station, 2 Station or 3 Station for multiple connections. Refer to Station kit Data sheets.**

### PRODUCT NUMBER

AT02-015	Polished	WM Straight no touch tap
----------	----------	--------------------------

### TECHNICAL DATA

Type of tap	Aquarius WM Straight	
Material	316 Stainless Steel	
Surface finish	Polished	
Gross weight	1.15 kg	
Type of operation	No Touch Sensor	
Type of mounting	Wall mounted	
Type of mixing	Additional TMV may be required	
Automatic purge	Yes* - Default: OFF Options: 3, 6, 12, 24, 36 & 48 hours Default 1 min*	
Purge run time	Options: OFF, 30 secs, 1, 2, 4 & 8 mins 170mm / 200mm	
Spout projection / Total tap length	1.00 bar (Lower pressure station kits available)	
Minimum flow pressure	5LPM (Other flow rates available)	
Volume flow rate at 3 bar	Yes* - Default: 2 secs	
Adjustable run time	Options: 2, 5, 10, 15, 20, 30 secs 15mm PEX hose	
Water connection	Yes	
Anti-Vandal function	Default OFF*	
Lock out function	Options: OFF, 4, 6, 8 & 10 operations Yes* - Default 2 mins	
Chlorination function	Options: 1, 2, 3, 4, 5, 10, 20 & 30 mins	
Battery or mains station kit	Single Battery: AT00-001 Single Mains: AT00-002 - Other options available. Contact DVS.	
Working pressure	1-10 Bar (For Low / High pressure, Contact DVS.)	
Max working temperature	60 °C	
Fixing	¾" BSP	
Fixing length	Up to 30mm with flange nut	

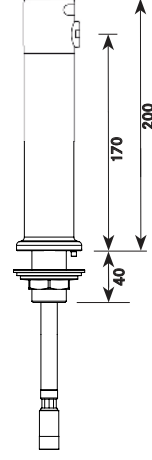

ALL DIMENSIONS IN MM



Last Updated: 2015-09-25, Dart Valley Systems



\* (Set By Handheld Programmer)

# AQUARIUS WM STRAIGHT

## Polished with Copper Tails

### AT02-016

The Aquarius range incorporate simple and modern design, with the latest electronic functionality.

Sensor operated for maximum hygiene and efficiency. 5 litres per minute integrated flow control. (Standard 5LPM, Other flow rates available)

Automatic purge function, Sensor range adjustment, Wave on/wave off function, Anti Vandal and Lock Out functions, Chlorination function.

Single mixed feed connection by Copper tail (10mm). External TMV required. Polished finish.

**Requires a Station kit to operate. Station kits available in Single Station Battery or Mains Single Station, 2 Station or 3 Station for multiple connections. Refer to Station kit Data sheets.**

#### PRODUCT NUMBER

AT02-016 Polished WM Straight no touch tap

#### TECHNICAL DATA

Type of tap	Aquarius WM Straight
Material	316 Stainless Steel
Surface finish	Polished
Gross weight	1.15 kg
Type of operation	No Touch Sensor
Type of mounting	Wall mounted
Type of mixing	Additional TMV may be required
Automatic purge	Yes* - Default: OFF Options: 3, 6, 12, 24, 36 & 48 hours Default 1 min*
Purge run time	Options: OFF, 30 secs, 1, 2, 4 & 8 mins 170mm / 200mm
Spout projection / Total tap length	1.00 bar (Lower pressure station kits available) 5LPM (Other flow rates available) Yes* - Default: 2 secs
Minimum flow pressure	Options: 2, 5, 10, 15, 20, 30 secs 10mm Copper tails
Volume flow rate at 3 bar	Yes
Adjustable run time	Default OFF*
Water connection	Options: OFF, 4, 6, 8 & 10 operations Yes* - Default 2 mins
Anti-Vandal function	Options: 1, 2, 3, 4, 5, 10, 20 & 30 mins
Lock out function	Single Battery: AT00-001 Single Mains: AT00-002 - Other options available. Contact DVS.
Chlorination function	1-10 Bar (For Low / High pressure, Contact DVS.)
Battery or mains station kit	60°C
Working pressure	¾" BSP
Max working temperature	Up to 30mm with flange nut
Fixing	
Fixing length	



ALL DIMENSIONS IN MM

Last Updated: 2015-09-25, Dart Valley Systems



\* (Set By Handheld Programmer)

# AQUARIUS WM STRAIGHT

Brushed with Pex Hose

## AT02-021

The Aquarius range incorporate simple and modern design, with the latest electronic functionality.

Sensor operated for maximum hygiene and efficiency. 5 litres per minute integrated flow control. (Standard 5LPM, Other flow rates available)

Automatic purge function, Sensor range adjustment, Wave on/wave off function, Anti Vandal and Lock Out functions, Chlorination function.

Single mixed feed connection by PEX lined hose (15mm connection). External TMV required. Brushed finish.

**Requires a Station kit to operate. Station kits available in Single Station Battery or Mains Single Station, 2 Station or 3 Station for multiple connections. Refer to Station kit Data sheets.**

### PRODUCT NUMBER

AT02-021      Brushed      WM Straight no touch tap

### TECHNICAL DATA

Type of tap	Aquarius WM Straight
Material	316 Stainless Steel
Surface finish	Polished
Gross weight	1.3 kg
Type of operation	No Touch Sensor
Type of mounting	Wall mounted
Type of mixing	Additional TMV may be required
Automatic purge	Yes* - Default: OFF Options: 3, 6, 12, 24, 36 & 48 hours Default 1min*
Purge run time	Options: OFF, 30 secs, 1, 2, 4 & 8 mins 220mm / 250mm
Spout projection / Total tap length	1.00 bar (Lower pressure station kits available)
Minimum flow pressure	5LPM (Other flow rates available)
Volume flow rate at 3 bar	Yes* - Default: 2 secs
Adjustable run time	Options: 2, 5, 10, 15, 20 & 30 secs 15mm PEX hose
Water connection	Yes
Anti-Vandal function	Default OFF*
Lock out function	Options: OFF, 4, 6, 8 & 10 operations Yes* - Default: 2 mins
Chlorination function	Options: 1, 2, 3, 4, 5, 10, 20 & 30 mins
Battery or mains station kit	Single Battery: AT00-001 Single Mains: AT00-002 - Other options available. Contact DVS.
Working pressure	1-10 Bar (For Low / High pressure, Contact DVS.)
Max working temperature	60 °C
Fixing	¾" BSP
Fixing length	Up to 30mm with flange nut

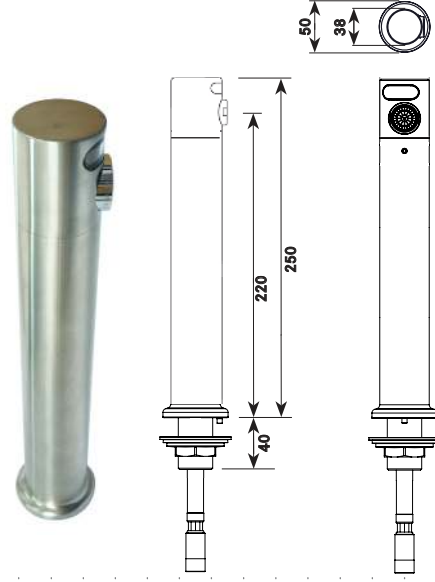

ALL DIMENSIONS IN MM

Last Updated: 2015-10-19, Dart Valley Systems



\* (Set By Handheld Programmer)

# AQUARIUS WM STRAIGHT

## Brushed with Copper Tails

### AT02-022

The Aquarius range incorporate simple and modern design, with the latest electronic functionality.

Sensor operated for maximum hygiene and efficiency. 5 litres per minute integrated flow control. (Standard 5LPM, Other flow rates available)

Automatic purge function, Sensor range adjustment, Wave on/wave off function, Anti Vandal and Lock Out functions, Chlorination function.

Single mixed feed connection by Copper tail (10mm). External TMV required. Brushed finish.

**Requires a Station kit to operate. Station kits available in Single Station Battery or Mains Single Station, 2 Station or 3 Station for multiple connections. Refer to Station kit Data sheets.**

#### PRODUCT NUMBER

AT02-022      Brushed      WM Straight no touch tap

#### TECHNICAL DATA

Type of tap	Aquarius WM Straight
Material	316 Stainless Steel
Surface finish	Brushed
Gross weight	1.3 kg
Type of operation	No Touch Sensor
Type of mounting	Wall mounted
Type of mixing	Additional TMV may be required
Automatic purge	Yes* - Default: OFF Options: 3, 6, 12, 24, 36 & 48 hours Default 1 min*
Purge run time	Options: OFF, 30 secs, 1, 2, 4 & 8 mins 220mm / 250mm
Spout projection / Total tap length	1.00 bar (Lower pressure station kits available)
Minimum flow pressure	5LPM (Other flow rates available)
Volume flow rate at 3 bar	Yes* - Default: 2 secs
Adjustable run time	Options: 2, 5, 10, 15, 20, 30 secs 10mm Copper tails
Water connection	Yes
Anti-Vandal function	Default OFF*
Lock out function	Options: OFF, 4, 6, 8 & 10 operations Yes* - Default 2 mins
Chlorination function	Options: 1, 2, 3, 4, 5, 10, 20 & 30 mins
Battery or mains station kit	Single Battery: AT00-001 Single Mains: AT00-002 - Other options available. Contact DVS.
Working pressure	1-10 Bar (For Low / High pressure, Contact DVS.)
Max working temperature	60°C
Fixing	¾" BSP
Fixing length	Up to 30mm with flange nut

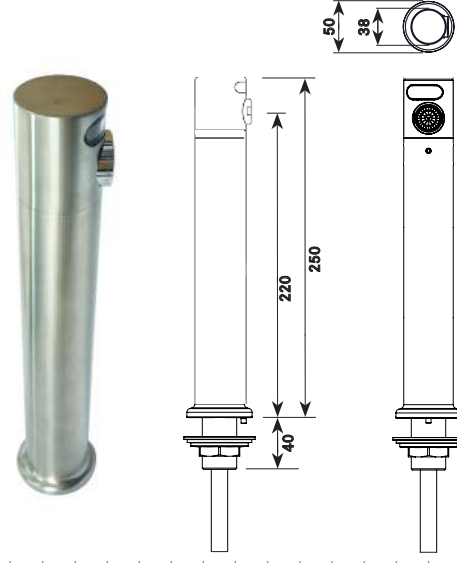

ALL DIMENSIONS IN MM

Last Updated: 2015-09-28, Dart Valley Systems



\* (Set By Handheld Programmer)

# AQUARIUS WM STRAIGHT

Polished with Pex Hose

## AT02-025

The Aquarius range incorporate simple and modern design, with the latest electronic functionality.

Sensor operated for maximum hygiene and efficiency. 5 litres per minute integrated flow control. (Standard 5LPM, Other flow rates available)

Automatic purge function, Sensor range adjustment, Wave on/wave off function, Anti Vandal and Lock Out functions, Chlorination function.

Single mixed feed connection by PEX lined hose (15mm connection). External TMV required. Polished finish.

**Requires a Station kit to operate. Station kits available in Single Station Battery or Mains Single Station, 2 Station or 3 Station for multiple connections. Refer to Station kit Data sheets.**

### PRODUCT NUMBER

AT02-025 Polished WM Straight no touch tap

### TECHNICAL DATA

Type of tap	Aquarius WM Straight
Material	316 Stainless Steel
Surface finish	Polished
Gross weight	1.3 kg
Type of operation	No Touch Sensor
Type of mounting	Wall mounted
Type of mixing	Additional TMV may be required
Automatic purge	Yes* - Default: OFF Options: 3, 6, 12, 24, 36 & 48 hours Default 1min*
Purge run time	Options: OFF, 30 secs, 1, 2, 4 & 8 mins 220mm / 250mm
Spout projection / Total tap length	1.00 bar (Lower pressure station kits available)
Minimum flow pressure	5LPM (Other flow rates available)
Volume flow rate at 3 bar	Yes* - Default: 2 secs
Adjustable run time	Options: 2, 5, 10, 15, 20 & 30 secs 15mm PEX hose
Water connection	Yes
Anti-Vandal function	Default OFF*
Lock out function	Options: OFF, 4, 6, 8 & 10 operations Yes* - Default: 2 mins
Chlorination function	Options: 1, 2, 3, 4, 5, 10, 20 & 30 mins
Battery or mains station kit	Single Battery: AT00-001 Single Mains: AT00-002 - Other options available. Contact DVS.
Working pressure	1-10 Bar (For Low / High pressure. Contact DVS.)
Max working temperature	60°C
Fixing	3/4" BSP
Fixing length	Up to 30mm with flange nut

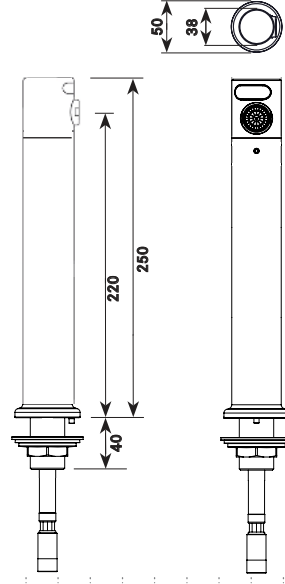

ALL DIMENSIONS IN MM

Last Updated: 2015-10-19, Dart Valley Systems



\* (Set By Handheld Programmer)

# AQUARIUS WM STRAIGHT

## Polished with Copper Tails

### AT02-026

The Aquarius range incorporate simple and modern design, with the latest electronic functionality.

Sensor operated for maximum hygiene and efficiency. 5 litres per minute integrated flow control. (Standard 5LPM, Other flow rates available)

Automatic purge function, Sensor range adjustment, Wave on/wave off function, Anti Vandal and Lock Out functions, Chlorination function.

Single mixed feed connection by Copper tail (10mm). External TMV required. Polished finish.

**Requires a Station kit to operate. Station kits available in Single Station Battery or Mains Single Station, 2 Station or 3 Station for multiple connections. Refer to Station kit Data sheets.**

#### PRODUCT NUMBER

AT02-026 Polished WM Straight no touch tap

#### TECHNICAL DATA

Type of tap	Aquarius WM Straight
Material	316 Stainless Steel
Surface finish	Polished
Gross weight	1.3 kg
Type of operation	No Touch Sensor
Type of mounting	Wall mounted
Type of mixing	Additional TMV may be required
Automatic purge	Yes* - Default: OFF Options: 3, 6, 12, 24, 36 & 48 hours Default 1min*
Purge run time	Options: OFF, 30 secs, 1, 2, 4 & 8 mins 220mm / 250mm
Spout projection / Total tap length	1.00 bar (Lower pressure station kits available)
Minimum flow pressure	5LPM (Other flow rates available)
Volume flow rate at 3 bar	Yes* - Default: 2 secs
Adjustable run time	Options: 2, 5, 10, 15, 20 & 30 secs 10mm Copper tails
Water connection	Yes
Anti-Vandal function	Default OFF*
Lock out function	Options: OFF, 4, 6, 8 & 10 operations Yes* - Default: 2 mins
Chlorination function	Options: 1, 2, 3, 4, 5, 10, 20 & 30 mins
Battery or mains station kit	Single Battery: AT00-001 Single Mains: AT00-002 - Other options available. Contact DVS.
Working pressure	1-10 Bar (For Low / High pressure, Contact DVS.)
Max working temperature	60°C
Fixing	¾" BSP
Fixing length	Up to 30mm with flange nut

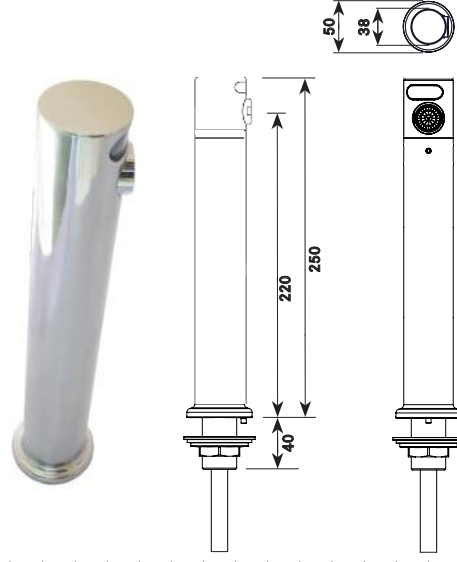

ALL DIMENSIONS IN MM

Last Updated: 2015-09-28, Dart Valley Systems



\* (Set By Handheld Programmer)