



Gas condensing boiler

D2CND

Welcome to Daikin's high efficiency gas condensing boiler





Gas condensing boilers

Why choose the Daikin gas condensing boiler?

Your customer requires a wall-mounted boiler to:

- › Simply replace their existing boiler
- › Provide heating and domestic hot water
- › Increase efficiency and lower operating costs

Solution - the Daikin gas condensing boiler:

- › Is compact in size
- › Has a low lift weight

Your customer gains:

- › Low operating costs due to high efficiencies
- › High quality touch and feel

You gain:

- › Plug-and-play replacement
- › Easy connections for simple installation

Result: win-win for you AND the customer

- › Heating: **A**
- › Hot water: up to* **A+++**

*When combined with solar thermal products

Daikin's high efficiency boiler

Compact in size and fully modulates down to 2.9kW, Daikin's gas condensing boiler provides users with reliable performance and efficient heating and hot water, making it the best option for both new and retrofit applications.

✓ Comfort and reliability

Daikin's gas condensing boiler delivers the ultimate in comfort; optimal heating ensures seamless operation to deliver reliable year-round heating.

Instant hot water is possible with our combi range, but can also be connected onto a cylinder for properties that have a larger hot water demand

✓ Quality components

Daikin has combined premium components, to offer the best quality boiler possible, including components from EBM Papst (Fan), SWEP (plate heat exchanger), Grundfos (Pump and hydroblock) and Kromschroder (Gas valve).



Gas condensing boiler

Supremely compact and controllable via app



Why choose the Daikin gas condensing boiler



Connectivity/Cloud Service

Smartphone app control
Always in control, no matter where you are

Easy installation and maintenance

All components are accessible from the front, side panels are removable for additional space if required.

Flexible in use

Adaptive gas valve works with either natural gas or LPG

Up to 11m flue runs

Low lift weight

27kg



Most compact

24 kW: 400 x 256 x 590 mm
28, 35 kW: 440 x 295 x 695 mm

Modulation 1:8

Controls combustion with shorter intervals and saves energy

Noise level

Ultra quiet operation

Daikin eye

Monitor the operating status of the boiler with the Daikin Eye

Unique interface

- › Stylish interface appeals to all end-users
- › State-of-the-art technology meets user-friendly design

High efficiency

Increasing comfort and giving you the lowest running costs possible, the Lambda Gx system allows the boiler to adapt to all systems. By controlling the fan and

gas valve, the burner capacity adjusts to ensure seamless and optimal operation of the boiler.

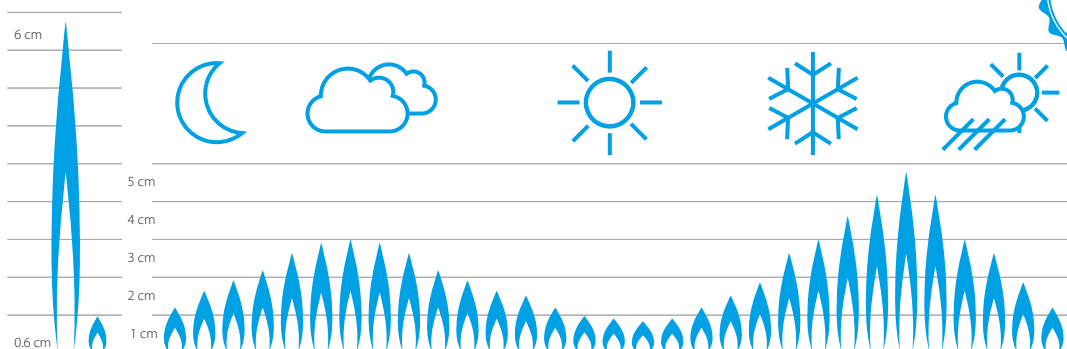



✓ Light and compact solution

The Daikin gas condensing boiler promises quick and hassle free installation every time. When the boiler was designed, a small footprint and low lift weight were key, to ensuring ease for our installers.

✓ Precision control

Ensuring optimal comfort in the property, Daikin's OpenTherm control system enables communication between the boiler and thermostat at all times, offering more precise control.

The smart comfort controller provides the end user with remote connection convenience via their smart device. Using the Daikin heating app, the user can view, monitor and adjust various settings to suit a busy lifestyle or a change of plans.

✓ Unique offering

A boiler made by Daikin, exclusively for Daikin customers. Stand out from the crowd and offer your customer a unique product.

✓ Warranty

Standard two years parts and labour warranty, with option to extend up to seven years.

✓ Training

The Daikin D2CND boiler is available at each of our UK training centres. To find out more, visit [training.daikinuk.com](https://www.daikinuk.com/training)



D2CND/D2TND-A1/4A

Gas condensing boiler

D2CND/D2TND-A1/4A

D2CND Boiler					
Part Number		D2CND024A4A	D2CND028A4A	D2CND035A4A	
Description		24kW Combi Boiler	28kW Combi Boiler	35kW Combi Boiler	
Seasonal space heating efficiency	Class	A	A	A	
	Efficiency	93.0%	93.1%	93.0%	
Water heating energy efficiency	Class	A	A	A	
	Declared load profile	XL	XL	XXL	
	Efficiency	84.0%	84.0%	83.0%	
Dimensions	Height x Width x Depth	mm	590 x 400 x 256		
Weight		kg	27	36	
Central Heating	Nom. Input rating (lower value)	kW	2.9 - 23.5	3.8 - 27.1	4.7 - 34
	Nom. Input rating (upper value)	kW	3.2 - 26.1	4.2 - 30.0	5.2 - 37.7
	Output at 80/60°C min - nom	kW	2.8 - 22.8	3.6 - 26.0	4.46 - 32.6
	Output at 50/30°C min - nom	kW	3.1 - 24.0	4.0 - 28.0	5.0 - 35.0
	Min. output at 30/40	kW	3.2	4.1	5.0
	Max. CH water pressure	bar	3		
	Max. CH water temperature	°C	80		
Domestic Hot Water	Nom. Input rating (lower value)	kW	2.9 - 23.5	3.8 - 27.1	4.7 - 34.0
	Nom. Input rating (upper value)	kW	3.2 - 26.1	4.2 - 30.0	5.2 - 37.7
	Nom. Output	kW	2.8 - 22.8	3.6 - 26.0	4.46 - 32.6
	Threshold	l/min	2		
	Flow rate ΔT 30°K	l/min	12.0	14.0	16.0
	Flow rate ΔT 35°K	l/min	10.3	12.0	13.7
Casing	Colour	Titanium White (RAL 9003) & Light Grey (RAL effect 860-1)			
	Material	Electrostatic powder coated sheet metal			
CH connections		inch	3/4"		
DHW connections		inch	1/2"		
Gas connection		inch	3/4"		
Sound power level		dBA	49	49	52
IP rating			IPX5D		
Device type			C13, C33		
Supply pressure	Natural gas (G20)	mbar	20		
	LPG (G31)	mbar	37		
Nox class			6		
Flue gas connection			60/100		
Maximum flue length, 60/100	Horizontal	m	11		
	Vertical	m	12.5		
Maximum flue length, 80/125	Horizontal	m	44		
	Vertical	m	42.8		
SAP 2012	Natural gas (G20)	%	TBC	TBC	TBC
	LPG (G31)	%	TBC	TBC	TBC
Power supply			1-phase / 230V / 50Hz		

Dimensions

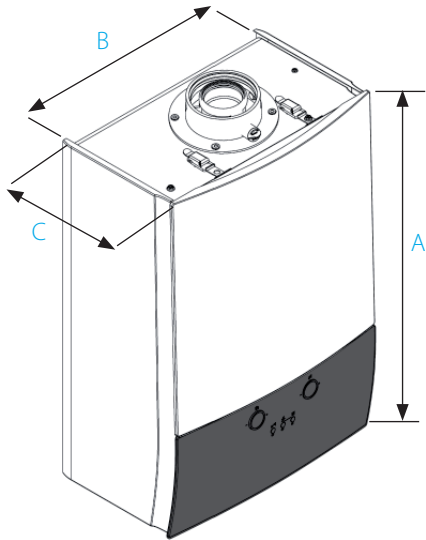

	24 kW	28 and 35 kW
A	590mm	695mm
B	400mm	440mm
C	256mm	295mm

Clearances

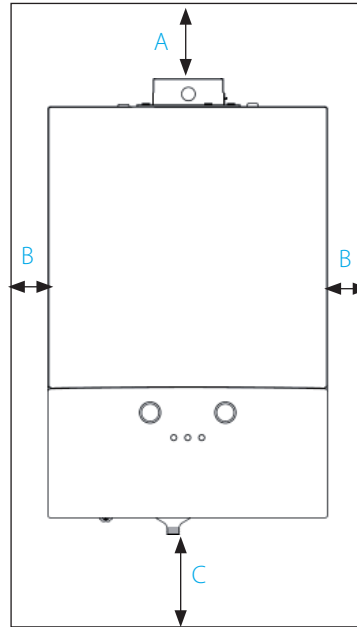

	Minimum clearances
A	180mm
B	10mm
C	200mm

Options

Description	Material Nr
Daikin OpenTherm room thermostat	DOTROOMTHEAA
D2C boiler Smart Comfort Controller	DRGATEWAYAA
Solar temperature sensor	DRSLRTESENSAA
Connector Elbow PP 60/100 + MP(0mm)*	DRMEEA60100BA
Twin Box Adapter 80/80 + MP(0mm)*	DRDECOP8080BA
Vert. Conn. 60/100-80/125 + MP(0mm)*	DRDECO80125BA
Cover plate (12-18-24 kW) ordered separately	DRCOVERPLATAA
Cover plate (28-35 kW) ordered separately	DRCOVERPLA2AA
Valve Kit C2 - 90° valves	DRVALVEKIC2AA
Outdoor sensor – Weather comp	150042
Horizontal flue terminal – 60/100	DRWTER60100AA



Trust Daikin

Daikin UK offers the most efficient heating, ventilation and air conditioning solutions, renowned for design excellence, quality and reliability. So you can depend on the ultimate in comfort for your customers.

Daikin UK has always prided itself on providing energy efficient and affordable heating solutions. And while we believe domestic heat pumps offer a future that makes greater use of renewable energy, we are also committed to offering options for every situation.

For some householders, energy efficient condensing boilers offer a value-for-money solution for existing dwellings. As a result, Daikin UK is expanding its portfolio of heating appliances with a range of state-of-the-art gas condensing boilers.

Compatible with a range of heat emitters, Daikin's boiler complements our industry-leading range of hybrid, heat pump and solar systems - all available exclusively from Daikin UK.

The Daikin D2CND boiler range can cover every demand, offering maximum convenience and maximum efficiency - without compromise.

daikin.co.uk

Heating installer line: 0845 641 9070

Dedicated homeowner support line: 0845 641 9271

The present leaflet is drawn up by way of information only and does not constitute an offer binding upon Daikin UK. Daikin UK has compiled the content of this leaflet to the best of its knowledge. No express or implied warranty is given for the completeness, accuracy, reliability or fitness for particular purpose of its content and the products and services presented therein. Specifications are subject to change without prior notice. Daikin UK explicitly rejects any liability for any direct or indirect damage, in the broadest sense, arising from or related to the use and/or interpretation of this leaflet. All content is copyrighted by Daikin UK.



FSC