



Data Center Solutions

All-in-one solutions from the leading cooling company.



Free cooling chillers

Compact free cooling chillers up to 2.150 kW

The chiller portfolio includes screw compressor units equipped with variable frequency drives (VFD) designed and manufactured in-house and mounted onto the compressor for better reliability and efficiency. Thanks to VFD, precise modulation of cooling loads is allowed, with capacities up to 2.150 kW and scroll compressor chillers with capacities up to 1.344 kW.

Despite their large cooling capacities, the Daikin products are compact, which allows them to be fitted in restricted areas. This is specifically true for free cooling units with a configuration that does not exceed the unit footprint.

Daikin offers different types of free cooling, including **glycol free** systems. Dedicated data center configuration includes an **integrated active harmonic filter**, directly into the unit's electrical panel to keep compactness.



Free cooling for lower operating costs

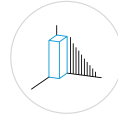

Compact footprint combined with large cooling capabilities

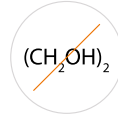

Glycol free, free cooling options

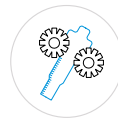

VFD screw compressor for improved reliability and efficiency

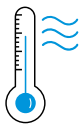

Max. leaving water temperature: +30 °C



Min. ambient temperature: -30 °C



Max. ambient temperature: +55 °C

Our chillers' heart

Daikin offers technology that is designed to be extremely reliable and durable, even in harsh environments. That is the case of the VFD screw compressor by Daikin, **designed and manufactured in-house** and mounted onto the compressor for better reliability and efficiency. It differentiates from other screw compressors for providing greater energy efficiency thanks to the optimised screw design and the integration of a specifically designed VFD.

This integration allows the compressor to perfectly match the different load requirements of the data center, through the capacity control of the compressor, resulting in outstanding part load efficiency, and thereby **low PUE** and low operating costs. On top of this, VFD and the integrated active low harmonics filter are both refrigerant cooled, further enhancing reliability, especially for those applications in extreme ambient conditions, where traditional air-cooled VFD would not be the best option.



Water cooled Trim Chiller & Heat Pump



Operating range

Compressor leaving water temp.

20°C

90°C

Chilled water

-8°C

45°C

Cooling capacity range: from 330 kW to 2000 kW

Heating capacity range: from 400 kW to 2100 kW

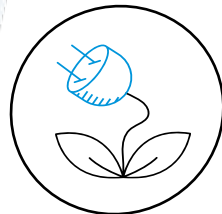

Sustainability at the core

Accelerating the decarbonization of process heating by replacing traditional boilers with renewable electricity systems, significantly reducing CO₂ emissions.

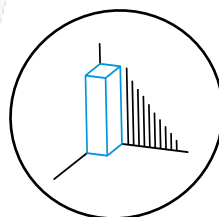

Flexible installation

Overcoming space and layout constraints with a compact, modular design and flexible connections, allowing easy integration into both new and existing plants.

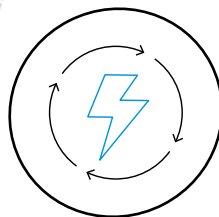

Advanced efficiency

The Inverter-driven screw compressors and VVR technology ensure high energy efficiency, stable performance, and low operating costs across varying conditions.

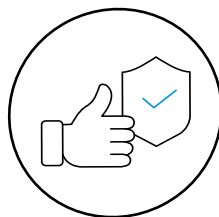

Consistent operational continuity

Featuring Daikin's Intelligent Chiller Manager (iCM), which optimizes performance, ensures temperature stability, and supports predictive maintenance.

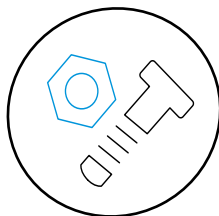

Comprehensive after-sales services

Comprehensive after-sales services, including remote monitoring, diagnostics, and condition-based maintenance, to ensure long-term reliability and ROI.

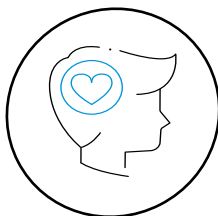

Performance peace of mind

All VZ units can undergo Factory Acceptance Testing (FAT) at Daikin Applied Europe's AHRI-certified facilities, ensuring seamless commissioning and consistent operational results on-site.



Intelligent Data Centre Manager

Unlike a traditional external controls system, Daikin's integrated iDCM requires **40% fewer sensors**. This allows the iDCM to make use of all unit data from the integrated unit sensors and controller.

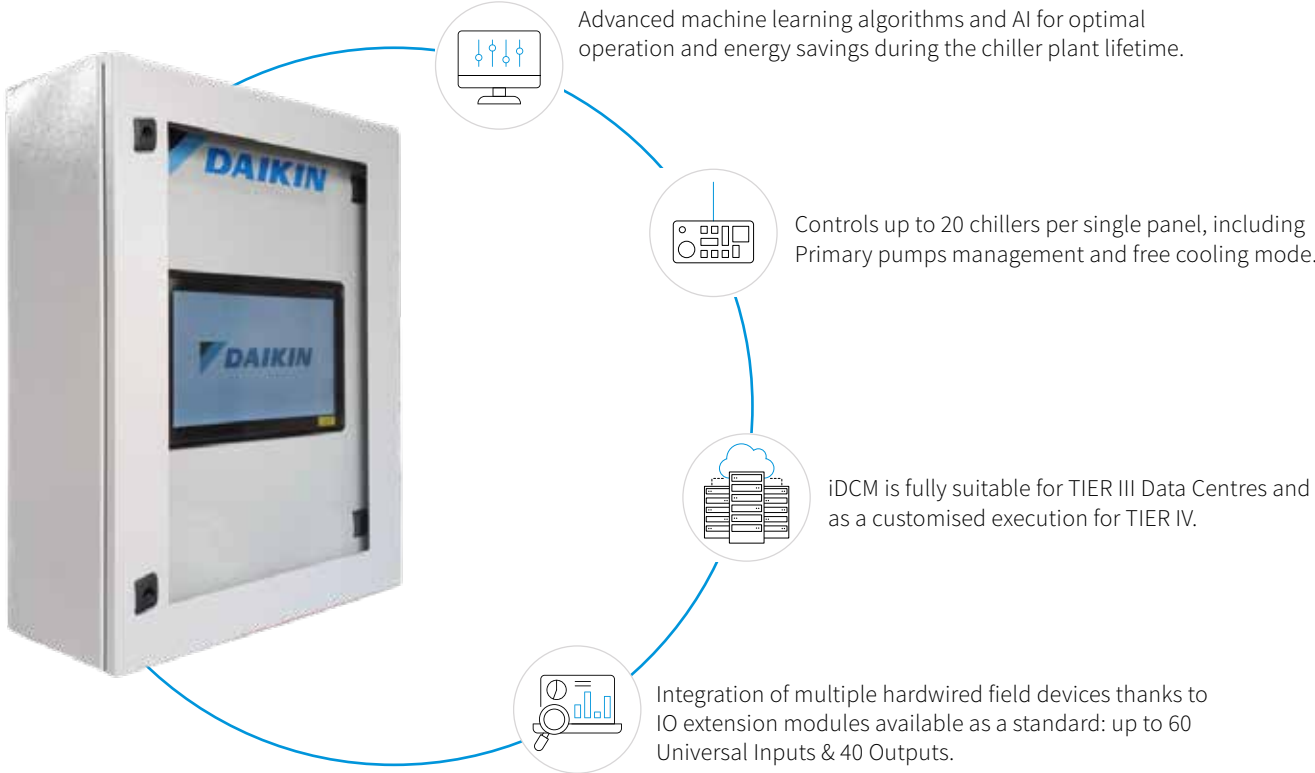

Key Benefits



Intelligent energy optimisation & **smart sequencing**, reducing energy consumption



Two optional configurations available: **Mild redundancy** or **Full redundancy**



Embedded **Daikin chiller control functions**, simplifying installation & maintenance

Control panel internal components

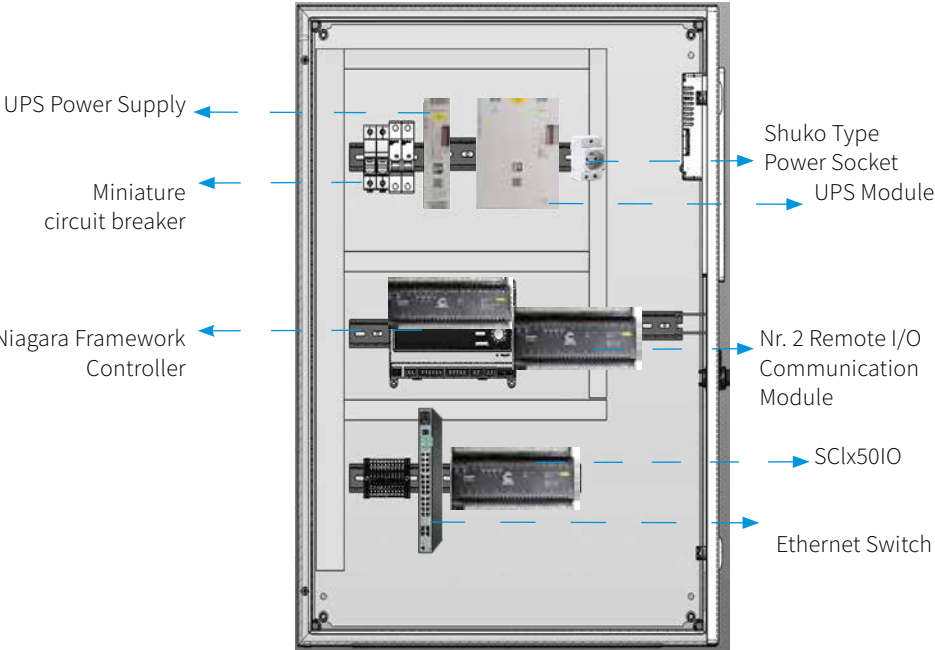

High efficiency fan array units

Meet the Pro-W. Our dedicated data center Computer Room Air Handling (CRAH) units are designed for large and hyperscale requirements – complete with chilled water coil, advanced controls for real-time demand and cooling capacity up to 500 kW.



Plug and play!

Air filters, control panel, UPS, fan array, cooling coil (up to 8 rows) and dampers are integrated according to your needs in an aluminium anodised profile casing on a hot deep galvanised base frame. The whole module is pre-tested and ready to use.



Controls that meet large and hyperscale data center requirements.



Pressure independent control valves (PICV) for a stable flow rate, improved temperature control and energy efficiency, reduced total start-up time and maintenance. Supplied separately or integrated.



Daikin EC fans with state-of-the-art efficiency and redundancy can be adjusted to your needs.

Pro C CRAH

Modular Computer Room Air Handling Unit

Developed to deliver the highest levels of efficiency and reliability, the unit features an optimized chilled water heat exchanger, a latest-generation EC fan with embedded PFC, and a factory-installed Energy PICV. The advanced, in-house developed control system ensures continuous operation through ATS, Ultracap and built-in redundancies.

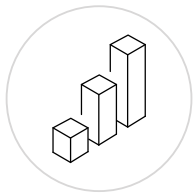

Wide cooling capacity range
from 30 kW to 200 kW

Key Benefits



Advanced in-house development control solution



Wide list of accessories

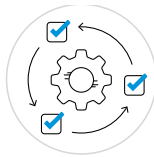

Flexible & modular design



Optimised Heat Exchanger for higher efficiency

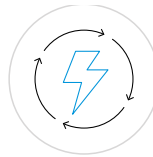

Latest generation EC fans

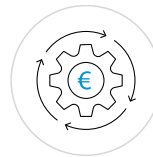

Group operation for reduced operational costs



Enhanced reliability through ATS & ultracap integration

Versatile configuration

Raised floor

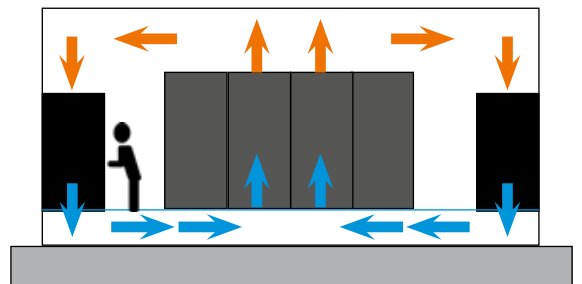
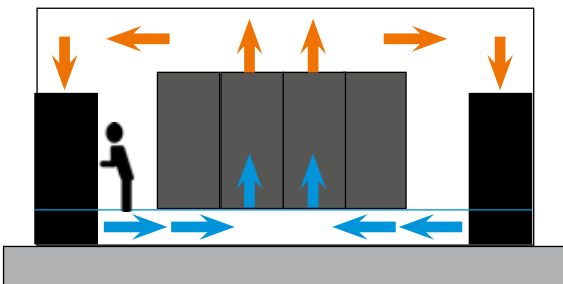

Hard Floor

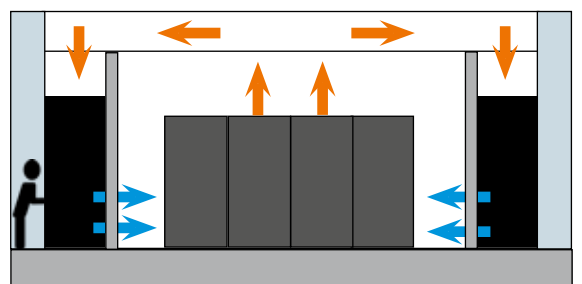
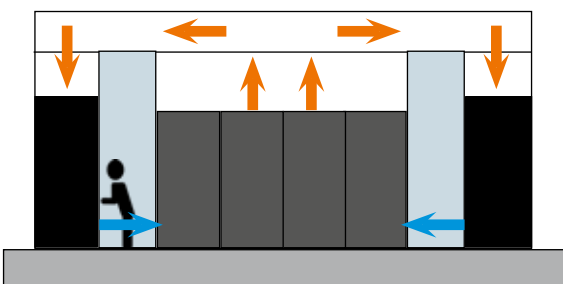

Smart Modular Design for Every Application

The CRAH range is designed around a **fully modular concept** that allows cooling capacity to be scaled easily and precisely. Each unit is built from standardised fan and chilled-water coil modules, starting from a base configuration with one fan and one coil. Higher sizes increase performance by adding fans and enlarging the heat exchange surface, delivering more airflow and cooling power. Intermediate configurations further refine this scaling by keeping the same number of fans while increasing coil size, to increase thermal exchange and reduce power consumption. This approach ensures a compact design across the range, while providing flexible, tailored cooling solutions for different load requirements.

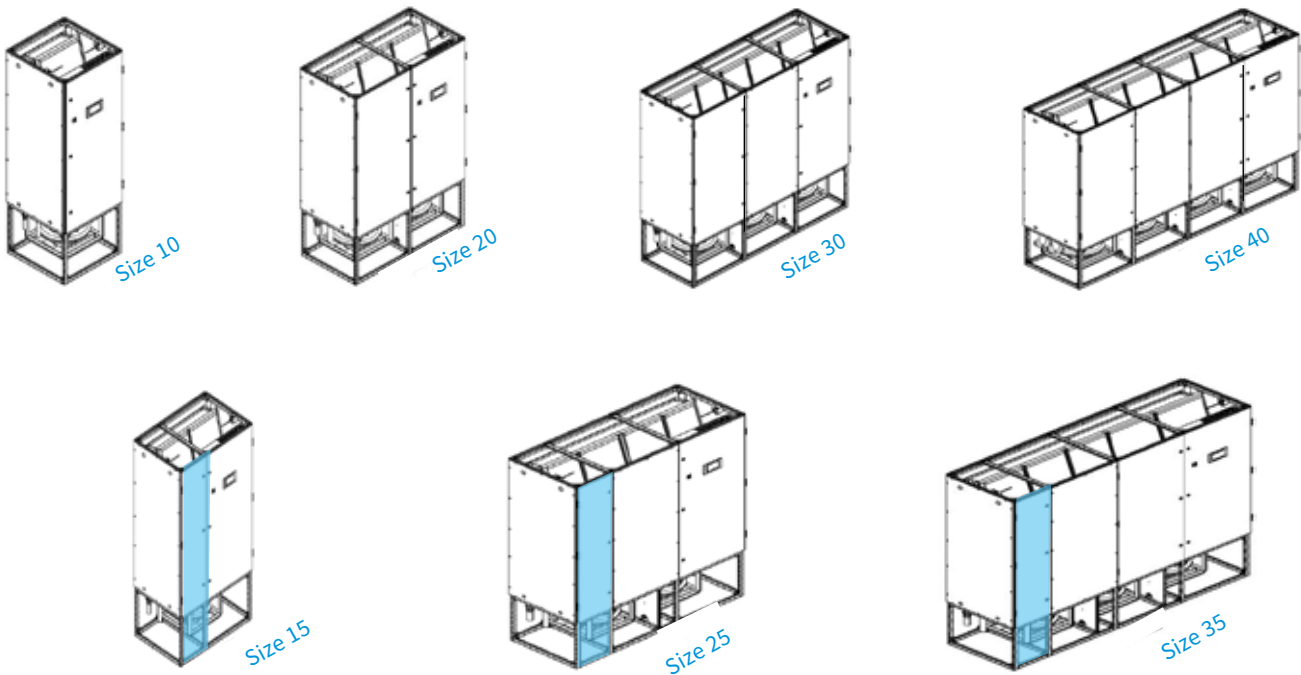

Technical data

		Size						
		10	15	20	25	30	35	40
Width	[mm]	890	1340	1740	2190	2590	3040	3440
Depth	[mm]	890	890	890	890	890	890	890
Height	[mm]	1975+675	1975+675	1975+675	1975+675	1975+675	1975+675	1975+675
Airflow	[m ³ /h]	10313	13658	23414	27037	36514	39302	50451
ESP	[Pa]	20	20	20	20	20	20	20
Net cooling capacity	[kW]	37	49	85	97	131	141	181
EER		20.0	20.0	20.0	20.0	20.0	20.0	20.0
Air Inlet T	[°C]	36	36	36	36	36	36	36
Air Outlet T	[°C]	25	25	25	25	25	25	25
Water Inlet T	[°C]	20	20	20	20	20	20	20
Water Outlet T	[°C]	28	28	28	28	28	28	28
Water DP (incl. ePICV)	[kPa]	30	44	40	46	57	53	60

Pro-W Slim

Smallest footprint solution on the market
for air & hybrid cooled Data Centre



Key Benefits

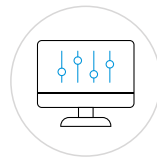

Internally developed advanced control



Plug & Play and ready to use



Cutting building construction costs

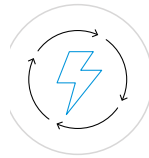

Energy-efficiency for sustainable operations

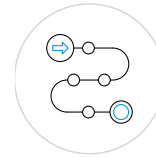

Quick installation thanks to fast assembly



Sectioned design for simplified transportation

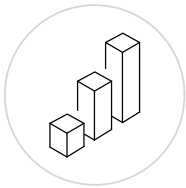

Cooling capacity range from 100 kW to 150 kW

The Daikin Fan Wall Slim delivers high cooling capacity with superior energy efficiency, significantly reducing power consumption and operating costs. Its compact design minimises construction requirements maximising usable space for IT racks. Thanks to its optimized engineering and advanced control strategies, the Pro-WS ensures precise temperature regulation, exceptional flexibility, built-in redundancy, and low lifecycle operating costs.

Technical data

		Size	
		10	15
Width	[mm]	1640	1640
Depth	[mm]	670	670
Height	[mm]	4950	5740
Airflow	[m3/h]	30000	39200
ESP	[Pa]	50	50
Net cooling cap	[kW]	115	152
EER		25	26
Air Inlet T	[°C]	36	36
Air Outlet T	[°C]	24	24
Water Inlet T	[°C]	20	20
Water Outlet T	[°C]	28	28

Airflow system layout

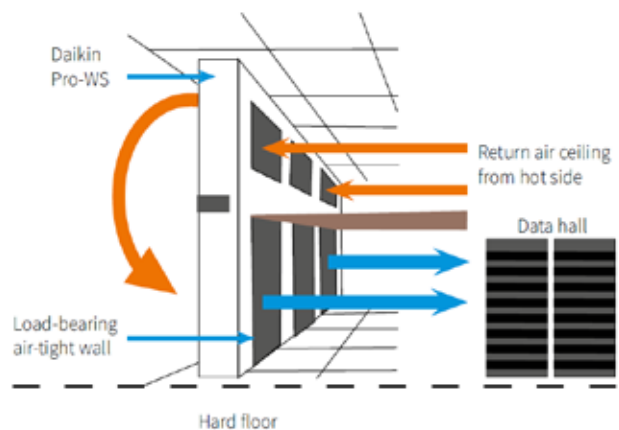

Coolant Distribution Unit - CDU

Direct to Chip Liquid Cooling
for Data-Centres and AI-Factory

Compact and powerful, the Daikin CDU is designed to fit any data centre layout, whether installed in-row, at the end of an aisle, or in a technical corridor. It delivers high efficiency with a low approach temperature (ATD down to 2K) and optimized pumping energy thanks to the IE5 motor. Engineered for maximum uptime, the CDU features pump redundancy and hot-swappable components. It precisely controls the leaving temperature on the TCS loop, maintaining constant coolant flow and pressure to respond rapidly to volatile AI thermal loads. It can meet any plant requirement with a wide range of options, including fully stainless-steel pumps, coolant filtration down to 25 µm, fully AISI-316 BPHE, integrated TDH < 5%, and an automatic transfer switch. Easy routine maintenance activities, with only front and rear service access.

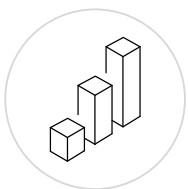

Available in three sizes,
from 400 kW up to over 2.5 MW.

Cooling capacity up to **10+ MW**
by grouping multiple CDUs on a
customisable skid.

Key Benefits

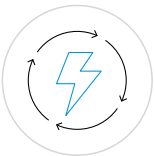

Optimised thermal
& hydronic
performance



Internally
developed
advanced control

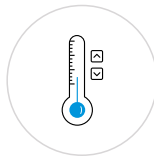

Precise and reliable
temperature
control

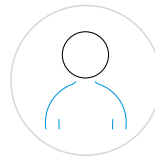

On-demand
customisation



Designed for
continuous
operation

Technical data

		Cooling Capacity kW						
		400 kW		1000 kW		2000 kW		
FWS Side	Fluid Type		Ethilenic 30%	Ethilenic 30%	Ethilenic 30%	Ethilenic 30%	Ethilenic 30%	Ethilenic 30%
	T_IN / T_OUT	[°C]	20 / 30	30 / 40	20 / 30	30 / 40	20 / 30	30 / 40
	Internal DP	[kPa]	40	14	56	26	56	77
	Stainless Stell Filtration	[µm]	500	500	500	500	500	500
TCS Side	Fluid Type		PG25	PG25	PG25	PG25	PG25	PG25
	T_IN / T_OUT	[°C]	34 / 24	44/32	34 / 24	44/32	34 / 24	44/32
	lpm / kW		1,5	1,2	1,5	1,2	1,5	1,2
	Approach Temperature (ATD)	[K]	4	2	4	2	4	2
	Stainless Stell Filtration	[µm]	down to 25	down to 25	down to 25	down to 25	down to 25	down to 25
	Electrical Power Input	[kW]	3,3	3,0	7,7	7,2	15,6	12,8
Available Ext. Pressure (low ESP)		230	230	250	230	250	240	

Legend : FWS - Facility Water System ; TCS - Technology Cooling System

Top class services

Wherever your data center may be, we are there, too. With a worldwide service and partner network, with over 13,000 employees in Europe, there are more than enough resources to cover all your needs.

6 Reasons to choose Daikin

- 1. Preventive Maintenance Plan:** Reliability over time with a detailed plan based on Daikin's 55 years of chiller technology experience, covering all necessary field activities and component checks.
- 2. Extended Warranty:** The standard one-year warranty is extendable up to four additional years, providing greater security and peace of mind for customers.
- 3. Global Service Availability:** With sales offices in over 170 countries, Daikin ensures service availability and expertise wherever and whenever needed, tailored to customer protocols.
- 4. Spare Parts Management:** Timely and professional supply of maintenance parts, with the option to manage spare parts stock directly at the customer's premises for simplified maintenance.
- 5. Comprehensive Maintenance Services:** Preventive and corrective maintenance, retrofit solutions, and upgrades to extend equipment life, to improve performance, and ensure consistent reliability.
- 6. Daikin on Site (DoS):** Cloud-based remote monitoring service offers real-time assessment, reporting, and intelligent maintenance to proactively prevent failures and minimise associated costs.

Rental Solutions

Daikin Rental is offering chillers, heat pumps, air handling, and power, to meet your temporary cooling needs while reducing CAPEX and optimising your OPEX. The Daikin Rental team is available 24/7 to address any situation.



Facility expansion

During facility expansions there is a need to test and adjust equipment, but not sufficient load to keep new or large chillers running. A simple rental solution ensures the correct load and energy efficiency while the expansion new build is being finalised.

Peak load support & seasonality

When the cooling demand of your facility exceeds your system's capacity due to high temperatures or changes to the cooling requirements, Daikin temporary cooling can be used to increase your cooling output and you save on capital expenditures.



Daikin Rental Solutions quickly responds on equipment failures. Our team of experts stands ready to assist you. every step of the way.



A temporary cooling system is used to back-up critical cooling, or when system redundancy has been reduced.



- Quickly restore normal operations
- Minimise financial losses and downtime
- Peace of mind during unexpected events
- Replacement of older equipment
- Our plans are designed to handle financial risks and ensure the right equipment size.

Green Mountain Data Centre

71

Free cooling
chillers

8

Control
systems

330

Fan array
units

115 MW total cooling capacity

For Norway's largest data center, OSL-Hamar (Green Mountain), Daikin delivered cutting-edge solutions that combine efficiency, integration, and long-term sustainability.

iDCM control system
energy saving results

Mechanical mode

13%

Energy saving

Free cooling

22%

Energy saving





For more information visit www.daikinapplied.uk/data-centre-solution

For Product, Service & Maintenance,
Rental and Spares enquiries:

 0345 565 2700

 www.daikinapplied.uk

 www.daikinrentalsolutions.uk

Follow us:
 www.linkedin.com/company/daikin-applied-uk-ltd/



Daikin Europe N.V. participates in the Eurovent Certified Performance programme for Fan Coil Units and Variable Refrigerant Flow systems. Daikin Applied Europe S.p.A participates in the Eurovent Certified performance programme for Liquid Chilling Packages, Hydronic Heat Pumps and Air handling Units. Check ongoing validity of certificate: www.eurovent-certification.com

The present publication is drawn up by way of information only and does not constitute an offer binding upon Daikin Applied (UK). Daikin Applied (UK) Ltd has compiled the content of this publication to the best of its knowledge. No express or implied warranty is given for the completeness, accuracy, reliability or fitness for particular purpose of its content and the products and services presented therein. Specifications are subject to change without prior notice. Daikin Applied (UK) Ltd explicitly rejects any liability for any direct or indirect damage, in the broadest sense, arising from or related to the use and/or interpretation of this publication.



Daikin Applied (UK) Ltd is certified to ISO 9001 Quality Management System (QMS), ISO 14001 Environmental Management System (EMS), and ISO 45001 Occupational Health and Safety (OH&S) management systems. For the latest certificates, visit www.daikinapplied.uk/documents-download

