

Model No : EDV-LR-BP

Overview

The Eau de Vie “LR model ” is a slot-in cassette version of the free standing variants. It can be installed on existing shelving and sited remotely from the dispense tap or taps, affording more flexibility in confined spaces. The Large Remote comes complete with an integral filter to ensure great tasting water. The water filter reduces chlorine, odours, particles, bad taste and health contaminants.

The cooling chamber is hidden inside with filters external for easy maintenance and replacement.

The unit is designed to dispense directly into glasses or Eau De Vie bottles which are distinguishable as still or sparkling water due to the bottle cap design.

Features

- Compact and flexible
- Capable of supplying quality fresh filtered water
- Water is supplied chilled with the option of still and sparkling
- Easy access for changing filters
- Simple to install
- Optional UV filter that kills bacteria which may be in the mains water
- Cooling capacity of 150 litres per hour
- 80 litres continuous supply
- Standard dimensions - 474(w) x 459(d) x 514(h)



Easy installation, connects to mains cold water supply and plugs into 2 x 13 amp sockets. Supplied with external water filters to provide premium quality tasting water.

The unit requires connection to a CO² cylinder which is housed externally and supplied by gas suppliers.

Benefits

- Free up valuable storage space
- Improved profits compared to bottled water
- Eco friendly
- Reduced environmental impact compared to transporting bottled water
- Reusable Eau De Vie branded bottles reduces waste disposal & recycling costs
- Provide added value to customers and employees
- Easy to operate by non skilled staff
- Hygienic and easy to keep clean
- A font for all occasions – chilled fresh filtered still & sparkling water (remotely sited)

Accessories

- Racks specifically designed for bottle washing
- Six bottle carrier
- Rack transportation dollies
- Branded 750ml or 500ml glass bottles
- “Still” Silver bottle top
- “Sparkling” Gold bottle top
- Branded paper cups
- Branded paper cup dispenser
- Branded aluminium water flasks
- Filters
- Sanitizing spray bottles (6 x 750 ml)
- Bottle Seal “Still”
- Bottle Seal “Sparkling”

Model No : EDV-LR

EAUdeVIE®

fresh filtered still & sparkling water systems

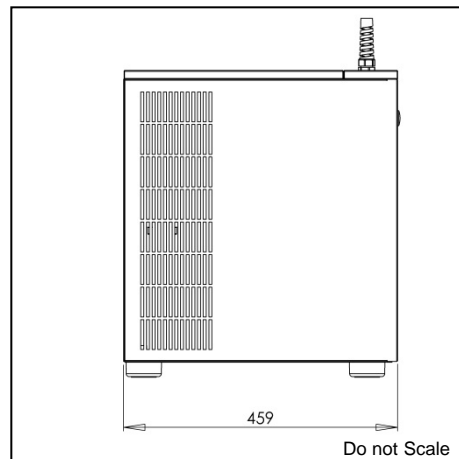
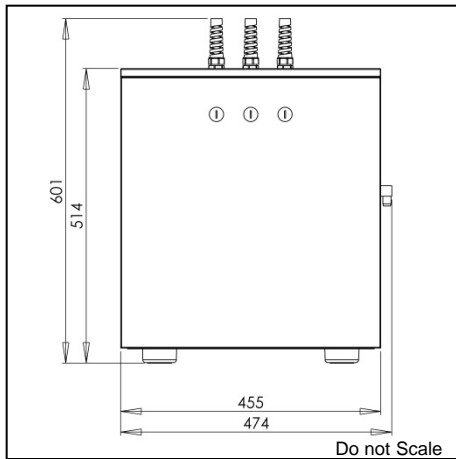

Dimensions (CAD blocks available upon application (00 44 (0)1908 359 000))

- Width 474 mm
- Depth 459 mm
- Height 514 mm

Water Connection

- Cold water mains potable supply
- Water Pressure $\frac{3}{4}$ BSP Isolator (3/4 BSP-3/8 Adaptor required)
Min 1.5 /Max 3.5 Bar
(No drainage required)
- Excess spillage into drip tray

Electrical Connection

- Mains Supply 230 V 1Ph 50 Hz Rated input 800 Watts
- Run Current 2.6 Amps
- Start Current 7.0 Amps
- Fuse at 10 Amps
- Supply Lead 2M Mains Cable 3 Pin UK Plug

Refrigeration Performance

- Ice bank weight 8 Kg Nominal
- Maximum ambient temperature 32°C
- Refrigerant type/charge Natural Hydrocarbon R290

Weight

- Packed 50 kg
- Unpacked 40 kg
- Operational 45 kg

Capacities based on incoming water temperatures



Classeq, Roebuck Way, Knowlhill, Milton Keynes, MK5 8WH.
Telephone: 00 44 (0)1908 359000 Fax: 00 44 (0)1908 359060
Email: sales@classeq.co.uk www.eaudevie.com

Part of the Winterhalter
group of companies