

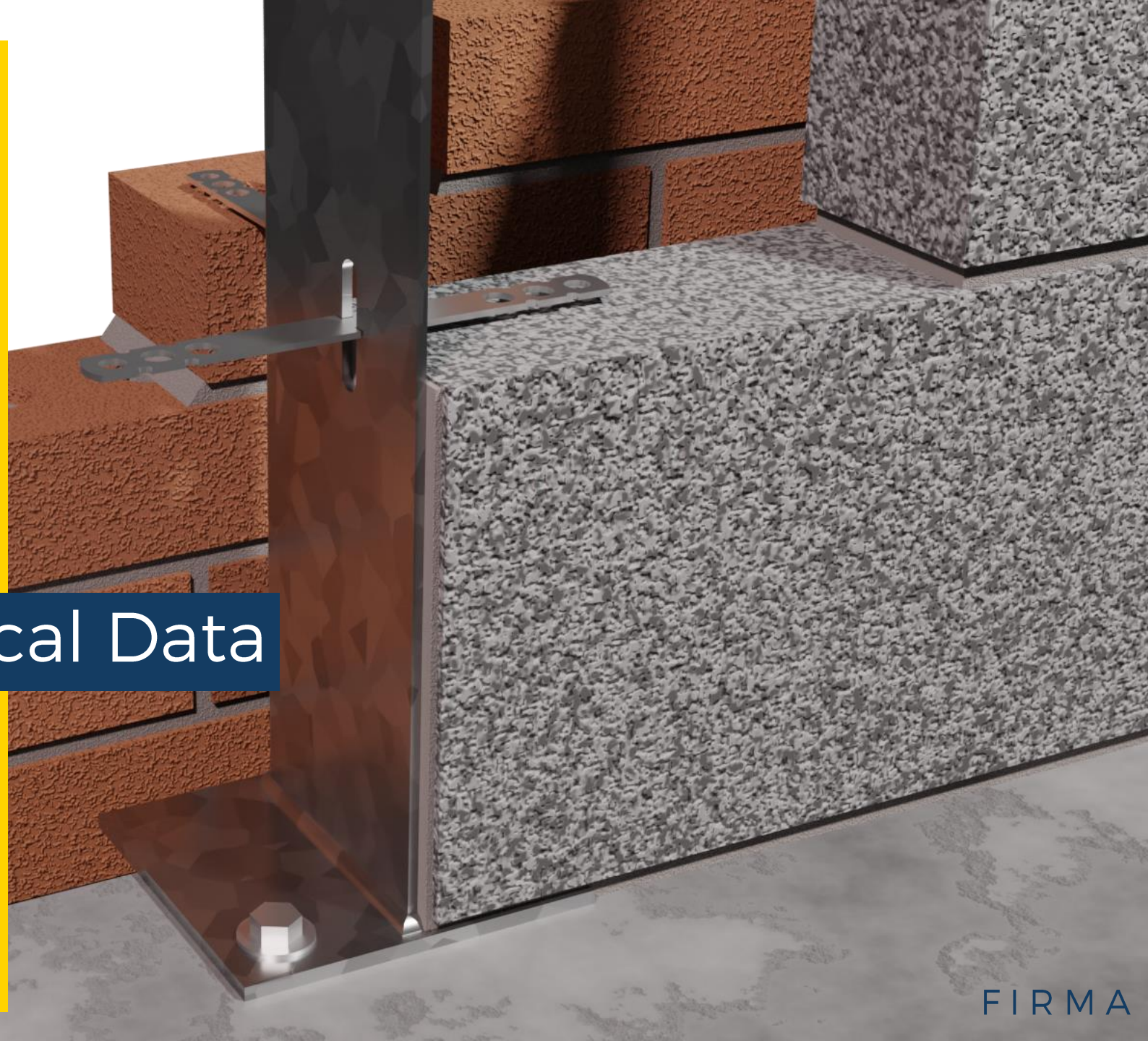

MARCH 2023

Windpost Technical Data

Non-combustible Windpost Systems
designed to increase safety and improve
standards for the construction industry



Our Product

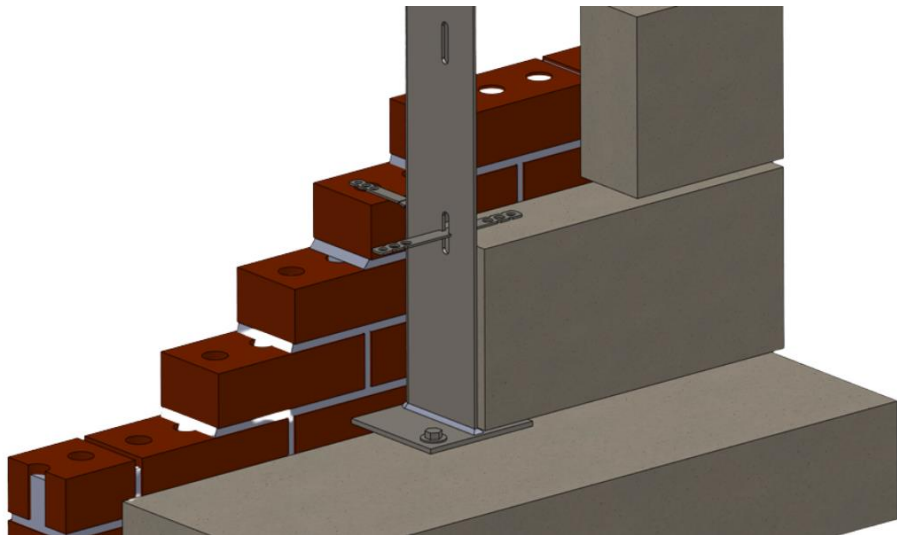

Scan QR Code to view full product range on our website!

WINDPOST CREDENTIALS

- > Fully **A1 rated** to comply with the Approved Document B 2019 amendments
- > Supplied complete with the appropriate fixing packs for simple **on-site installation**
- > Full design and scheduling service included as standard. Product **cut and manufactured** to schedule to facilitate fast site installation
- > Full structural calculations provided where required, ensuring full compliance
- > Available on 3-4-week lead times, subject to a review of project requirements

Stainless steel mild steel wind posts for structural **facades** and **brick walls**.

Typically used to span vertically between floors of a building to provide **additional structural strength** to a wall where wind loads need to be accounted for.

2.

Call 01603 722330 web www.firma.co.uk email info@firma.co.uk

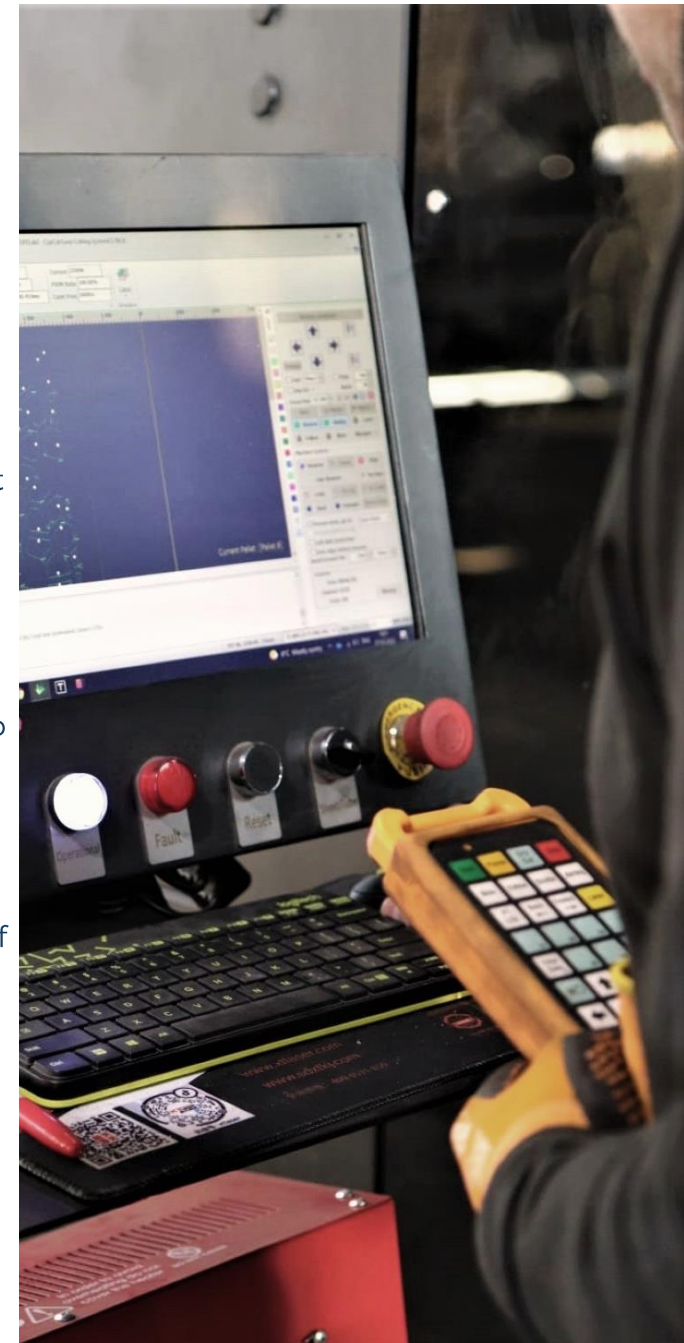

Windpost Profiles

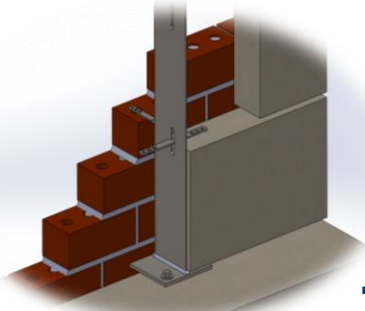

1

L-Profile Windposts

Angle profile wind posts are used where there is a small cavity to the wall and one leg of the angle is built into the blockwork and is effective where high wind loads are allowed for.

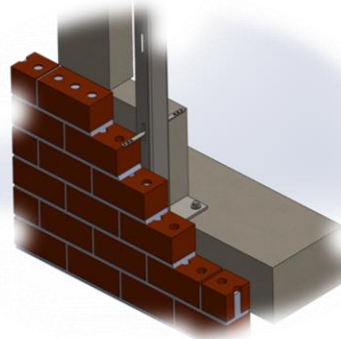

2

C-Profile Windposts

A C-Profile wind post is designed to be installed or concealed in the cavity of a wall. The slotted holes allow for simple attachment of the brick ties to be built into the blockwork.

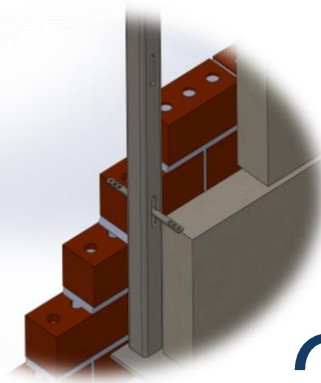

3

Box-Profile Windposts

Box profile wind posts are generally designed to be fitted in line with a single block wall with brick ties fixed to the box section and built into the block coursing.

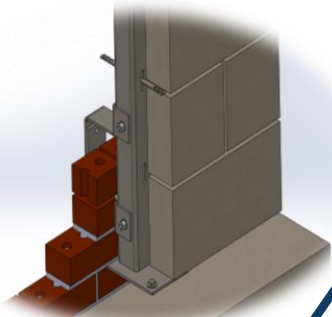

4

Parapet Windposts

These posts are designed and engineered differently to standard wind posts in that the posts are cantilevered instead of being fixed at both ends vertically.

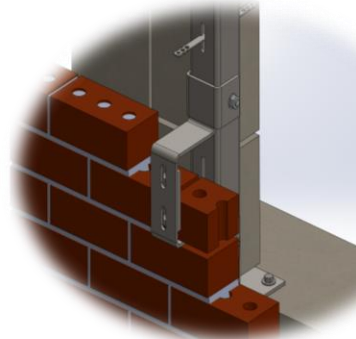

5

Parapet & Balustrade Windposts

There is often a requirement for a low-level brick parapet with aluminium or stone copings with a low-level balustrade in glass or steel to provide protection to the edge of the terrace or balcony to a minimum of 1100mm from the finished floor.

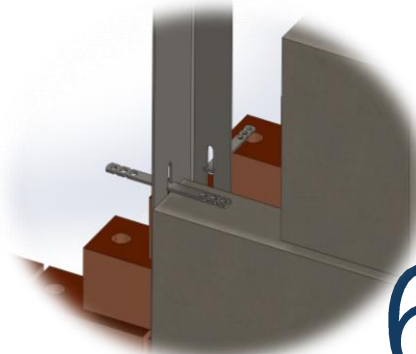

6

Masonry Ties

Stainless steel wall ties to connect with BA Windposts.

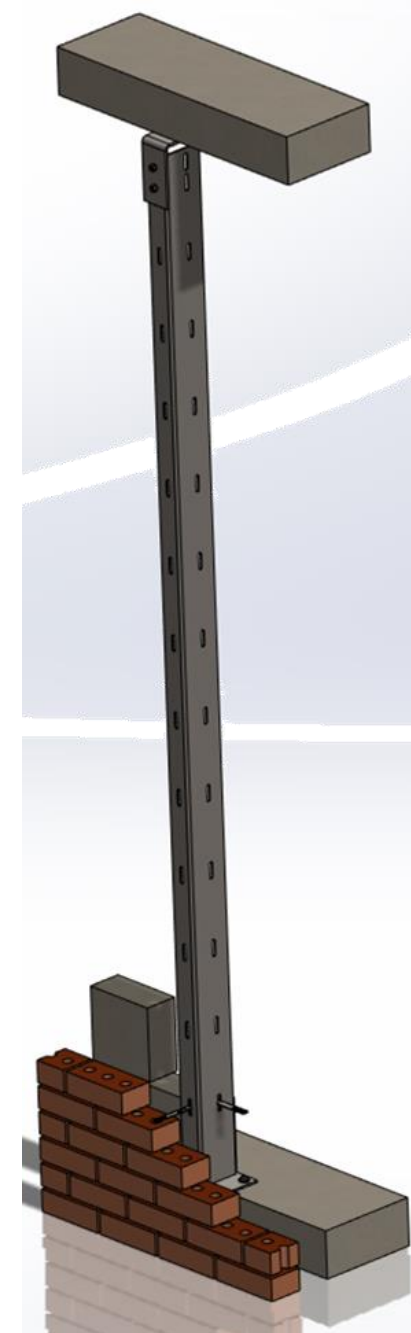

L-Profile Windpost

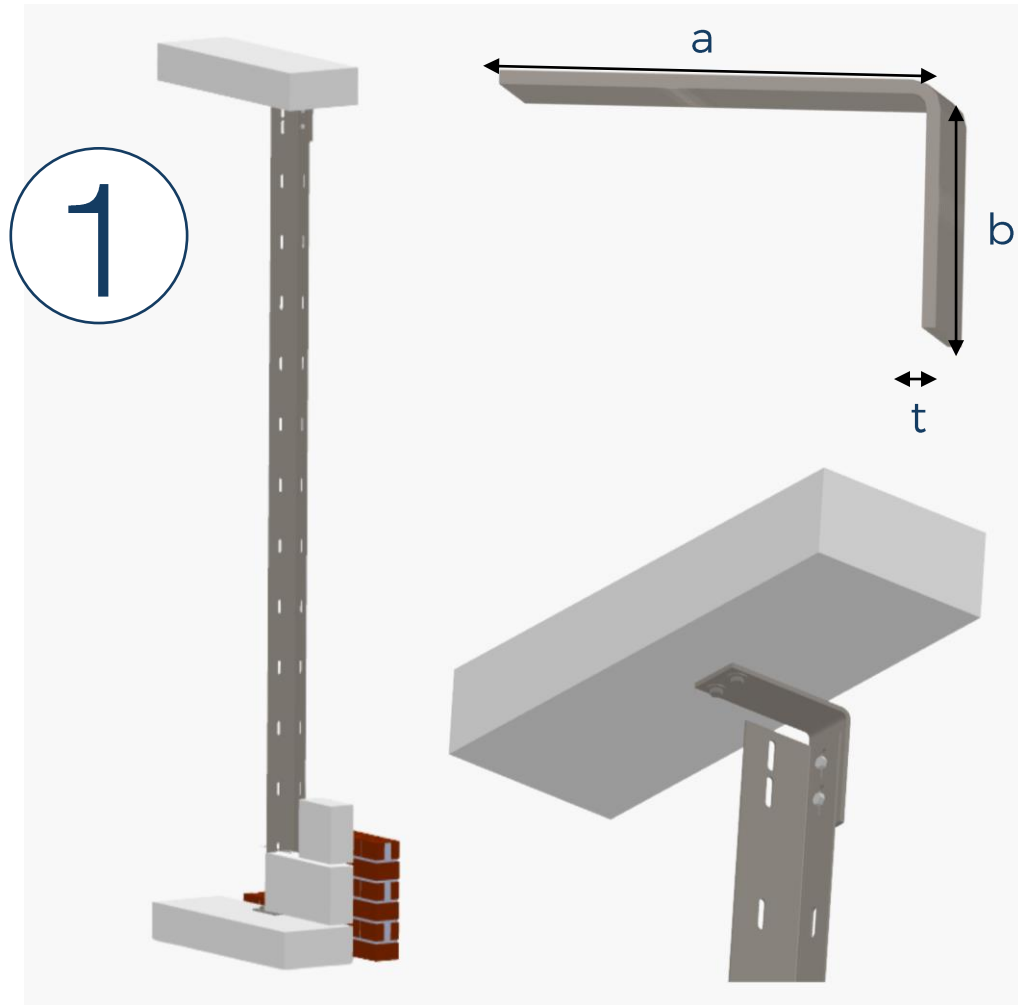

L Profile Windposts are usually used with smaller wall cavities and can be built into the inner brick or block skin. The posts are pre cut with slots for fixing to the outer skin with stainless steel brick ties. Slots in the header bracket facilitate simple installation with tolerance to allow for discrepancies in the steel or concrete substrate.

Stainless Steel Grade 304		
e	200000	MPa
f _y	191	MPa
Deflection limits for Serviceability:		
Wind Post (simply supported): Post height/360		

L Angle Wind Post			L Angle Profile Simply Supported Wind Post Height (mm)							
Section	I _{xx}	Z _{xx}	2500	3000	3500	4000	4500	5000	5500	6000
(axbxt)	mm ⁴ x10 ⁻⁶	mm ³ x10 ⁻³	Total allowable Ultimate Horizontal Load on Wind Post (kN)							
125x70x4 L	1.266	15.286	9.3	7.8	6.6	5.1	4.0	3.2	2.7	2.3
140x70x4 L	1.721	18.875	11.5	9.6	8.2	6.9	5.4	4.4	3.6	3.1
130x70x6 L	2.044	24.172	14.8	12.3	10.6	8.2	6.5	5.2	4.3	3.6
155x70x4 L	2.266	22.800	13.9	11.6	10.0	8.7	7.2	5.8	4.8	4.0
170x70x4 L	2.909	27.054	16.5	13.8	11.8	10.3	9.2	7.4	6.2	5.2
150x70x6 L	3.019	31.593	19.3	16.1	13.8	12.1	9.5	7.7	6.4	5.4
160x70x6 L	3.599	35.635	21.8	18.1	15.6	13.6	11.4	9.2	7.6	6.4
185x70x4 L	3.657	31.633	19.3	16.1	13.8	12.1	10.7	9.4	7.7	6.5
150x80x8 L	4.068	42.203	24.8	21.5	18.4	16.1	12.9	10.4	8.6	7.2
185x70x5 L	4.511	39.224	24.0	20.0	17.1	15.0	13.3	11.5	9.5	8.0
160x80x8 L	4.855	47.647	24.8	24.3	20.8	18.2	15.3	12.4	10.3	8.6
200x70x5 L	5.574	45.318	24.8	23.1	19.8	17.3	15.4	13.8	11.8	9.9

C-Profile Windpost

2

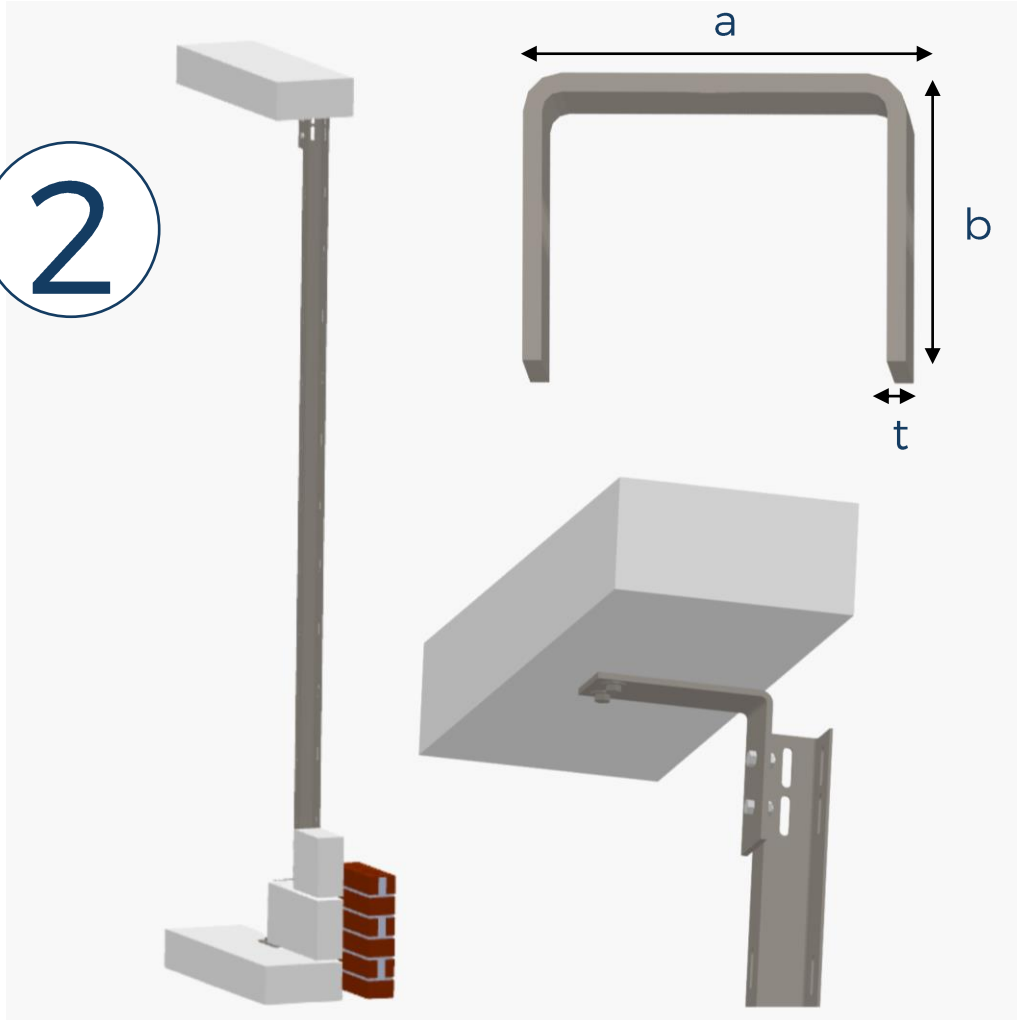

C Profile Windposts are designed to fit into the cavity with no interruption to the brick or blockwork. Stainless steel ties then support the blockwork off the windposts. Data is available as below on some standard sizes but windposts can be fabricated in house to specific or bespoke requirements. Slots in the header bracket facilitate simple installation with tolerance to allow for discrepancies in the steel or concrete substrate.

Stainless Steel Grade 304		
e	200000	MPa
f _y	191	MPa
Deflection limits for Serviceability:		
Wind Post (simply supported): Post height/360		

C Profile Wind Post			C Profile Simply Supported Wind Post Height (mm)							
Section (axbxt)	I _{xx} mm ⁴ x10 ⁻⁶	Z _{xx} mm ³ x10 ⁻³	2500	3000	3500	4000	4500	5000	5500	6000
			Total allowable Ultimate Horizontal Load on Wind Post (kN)							
55x60x4 _C	0.333	12.097	3.4	2.4	1.7	1.3	1.1	0.9	0.7	0.6
55x60x5 _C	0.392	14.239	4.0	2.8	2.0	1.6	1.2	1.0	0.8	0.7
65x60x4 _C	0.488	15.020	5.0	3.5	2.6	2.0	1.5	1.2	1.0	0.9
65x60x5 _C	0.579	17.803	5.9	4.1	3.0	2.3	1.8	1.5	1.2	1.0
75x60x4 _C	0.678	18.081	6.9	4.8	3.5	2.7	2.1	1.7	1.4	1.2
75x60x5 _C	0.808	21.539	8.3	5.7	4.2	3.2	2.6	2.1	1.7	1.4
85x60x4 _C	0.904	21.277	9.3	6.4	4.7	3.6	2.9	2.3	1.9	1.6
85x60x5 _C	1.082	25.447	11.1	7.7	5.7	4.3	3.4	2.8	2.3	1.9
95x60x5 _C	1.402	29.525	14.4	10.0	7.3	5.6	4.4	3.6	3.0	2.5
105x60x5 _C	1.773	33.771	16.5	12.6	9.3	7.1	5.6	4.5	3.8	3.2
115x60x5 _C	2.196	38.186	16.5	15.6	11.5	8.8	6.9	5.6	4.6	3.9
115x60x6 _C	2.540	44.173	16.5	16.5	13.3	10.2	8.0	6.5	5.4	4.5

Box Profile Windpost

3



Box profile Windposts are for building within the blockwork but can also be used in cavities if required. Stainless steel ties are usually fixed to these with self-drilling fixings also available from BA Systems. Basic data is available on these simply supported windposts. Slots in the header bracket facilitate simple installation with tolerance to allow for discrepancies in the steel or concrete substrate.

Stainless Steel Grade 304	
e	200000 MPa
fy	191 MPa
Deflection limits for Serviceability:	
Wind Post (simply supported): Post height/360	

SHS Wind Post			Square Hollow Section Simply Supported Wind Post Height (mm)							
Section (axaxt)	I_{xx} mm ⁴ x10 ⁻⁶	Z_{xx} mm ³ x10 ⁻³	2500	3000	3500	4000	4500	5000	5500	6000
Total allowable Ultimate Horizontal Load on Wind Post (kN)										
SHS 80 / 4	1.145	28.61	11.7	8.1	6.0	4.6	3.6	2.9	2.4	2.0
SHS 80 / 5	1.366	34.15	14.0	9.7	7.1	5.5	4.3	3.5	2.9	2.4
SHS 90 / 4	1.663	36.95	17.0	11.8	8.7	6.7	5.3	4.3	3.5	3.0
SHS 90 / 5	1.996	44.35	20.4	14.2	10.4	8.0	6.3	5.1	4.2	3.5
SHS 100 / 4	2.318	46.36	23.7	16.5	12.1	9.3	7.3	5.9	4.9	4.1
SHS 100 / 5	2.794	55.89	28.6	19.9	14.6	11.2	8.8	7.2	5.9	5.0
SHS 120 / 5	4.977	82.95	30.0	35.4	26.0	19.9	15.7	12.7	10.5	8.8
SHS 140 / 5	8.075	115.4	30.0	36.0	42.2	32.3	25.5	20.7	17.1	14.4
SHS 150 / 5	10.02	133.6	30.0	36.0	42.0	40.1	31.7	25.7	21.2	17.8
SHS 180 / 5	17.65	196.1	30.0	36.0	42.0	48.0	54.0	45.2	37.3	31.4
SHS 200 / 5	24.45	244.5	30.0	36.0	42.0	48.0	54.0	60.0	51.7	43.5
SHS 200 / 6.3	30.11	301.1	30.0	36.0	42.0	48.0	54.0	60.0	63.7	53.5

Parapet Windposts

Box Profile

4a.

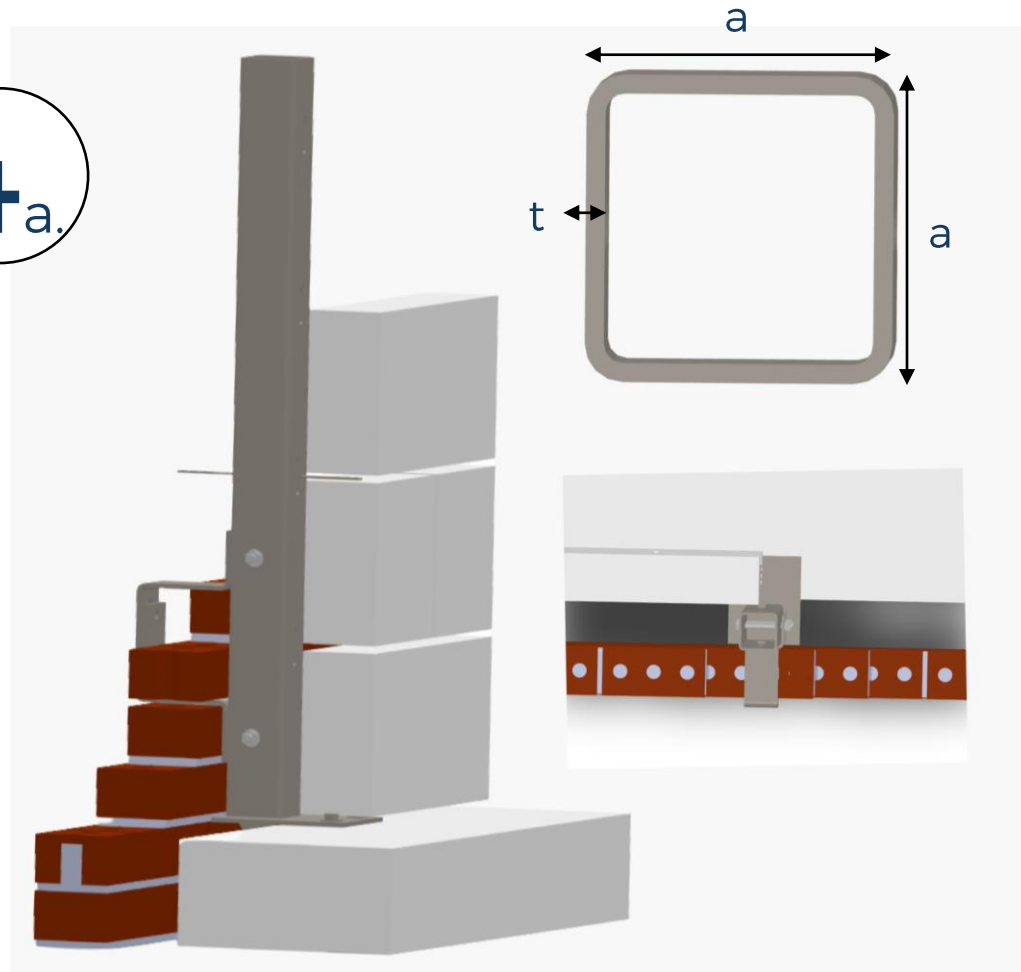

Almost any size of Box profile, L Profile or C Profile can be designed to be used as a parapet windpost. This windpost acts as a cantilever and data on these cantilevered loads are shown on the different profiles below.

Stainless Steel Grade		
304		
e	200000	MPa
fy	191	MPa
Deflection limits for Servicability:		
Parapet Post (cantilever): Post height/180		

SHS Parapet Post			Fixed Base Square Hollow Section Parapet Post Height (mm)						
Section (axaxt)	I _{xx} mm ⁴ × 10 ⁻⁶	Z _{xx} mm ³ × 10 ⁻³	800	1000	1200	1400	1600	1800	2000
Total allowable Ultimate Horizontal Load on Parapet Post (kN)									
SHS 80 / 4	1.145	28.61	9.6	10.9	9.1	7.8	6.0	4.7	3.8
SHS 80 / 5	1.314	32.86	9.6	12.0	10.5	8.9	6.8	5.4	4.4
SHS 90 / 4	1.663	36.95	9.6	12.0	11.8	10.1	8.7	6.8	5.5
SHS 90 / 5	1.996	44.35	9.6	12.0	14.1	12.1	10.4	8.2	6.7
SHS 100 / 4	2.318	46.36	9.6	12.0	14.8	12.6	11.1	9.5	7.7
SHS 100 / 5	2.794	55.89	9.6	12.0	15.0	15.2	13.3	11.5	9.3
SHS 120 / 5	4.977	82.95	9.6	12.0	15.0	18.0	19.8	17.6	15.8
SHS 140 / 5	8.075	115.4	9.6	12.0	15.0	18.0	21.0	24.0	22.0
SHS 150 / 5	10.020	133.6	9.6	12.0	15.0	18.0	21.0	24.0	24.0
SHS 180 / 5	17.650	196.1	9.6	12.0	15.0	18.0	21.0	24.0	24.0
SHS 200 / 5	24.450	244.5	9.6	12.0	15.0	18.0	21.0	24.0	24.0
SHS 200 / 6.3	30.110	301.1	9.6	12.0	15.0	18.0	21.0	24.0	24.0

Parapet Windposts

L-Angle

4_b

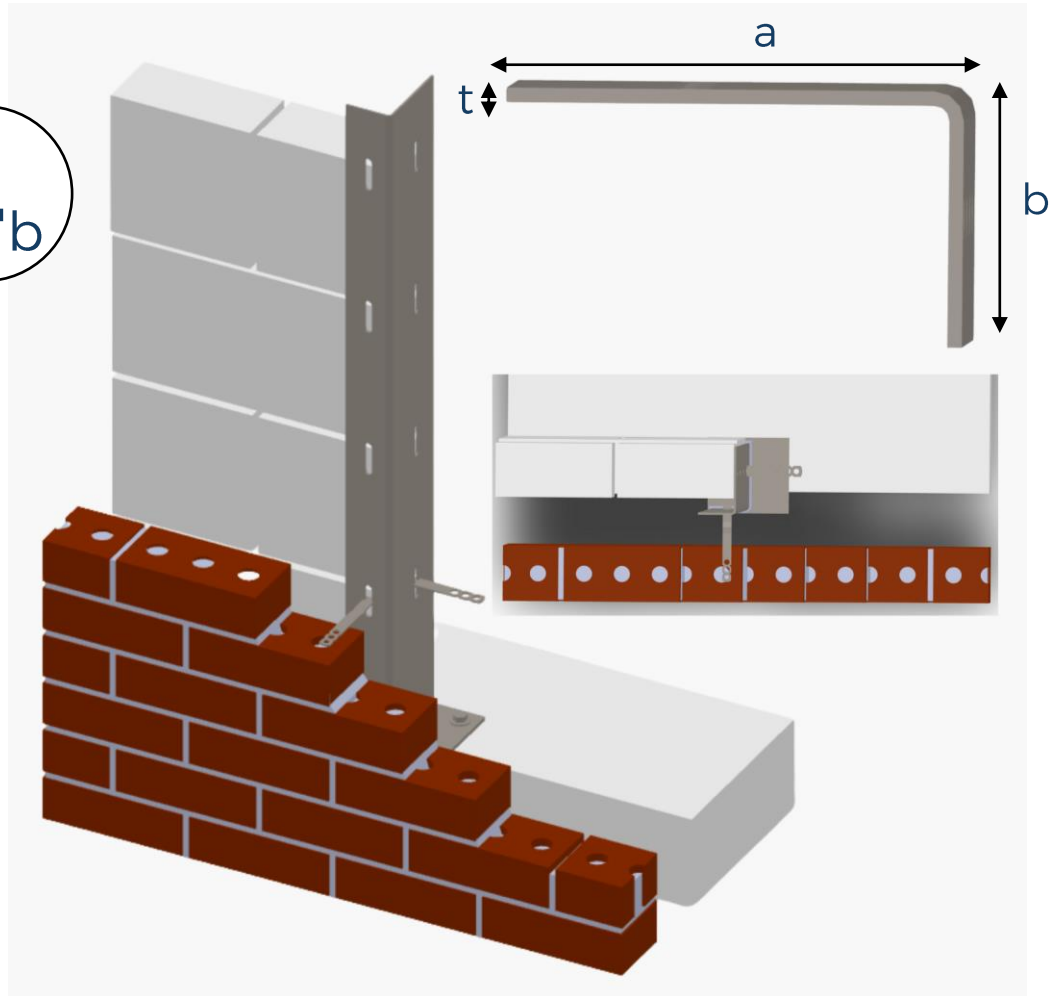

Almost any size of Box profile, L Profile or C Profile can be designed to be used as a parapet windpost. This windpost acts as a cantilever and data on these cantilevered loads are shown on the different profiles below.

Stainless Steel Grade 304	
e	200000 MPa
fy	191 MPa
Deflection limits for Servicability:	
Parapet Post (cantilever): Post height/180	

L Angle Parapet Post			Fixed Base L Angle Section Parapet Post Height (mm)						
Section	Ixx	Zxx	800	1000	1200	1400	1600	1800	2000
(axbxt)	mm ⁴ x10 ⁻⁶	mm ³ x10 ⁻³	Total allowable Ultimate Horizontal Load on Parapet Post (kN)						
125x70x4 L	1.266	15.29	6.8	5.8	4.9	4.2	3.6	3.2	2.9
140x70x4 L	1.721	18.88	6.8	7.2	6.0	5.2	4.5	4.0	3.6
130x70x6 L	2.044	24.17	6.8	9.0	7.7	6.6	5.8	5.1	4.6
155x70x4 L	2.044	24.17	6.8	9.0	7.7	6.6	5.8	5.1	4.6
170x70x4 L	2.909	27.05	6.8	9.0	8.6	7.4	6.5	5.7	5.2
150x70x6 L	3.019	31.59	6.8	9.0	10.1	8.6	7.5	6.7	6.0
160x70x6 L	3.599	35.63	6.8	9.0	11.3	9.7	8.5	7.6	6.8
185x70x4 L	3.657	31.63	6.8	9.0	10.1	8.6	7.6	6.7	6.0
150x80x8 L	4.068	42.20	6.8	9.0	11.3	11.5	10.1	9.0	8.1
185x70x5 L	4.068	42.20	6.8	9.0	11.3	11.5	10.1	9.0	8.1
160x80x8 L	4.855	47.65	6.8	9.0	11.3	13.0	11.4	10.1	9.1
200x70x5 L	5.574	45.32	6.8	9.0	11.3	12.4	10.8	9.6	8.7

Parapet Windposts

C-Profile

4_{C.}

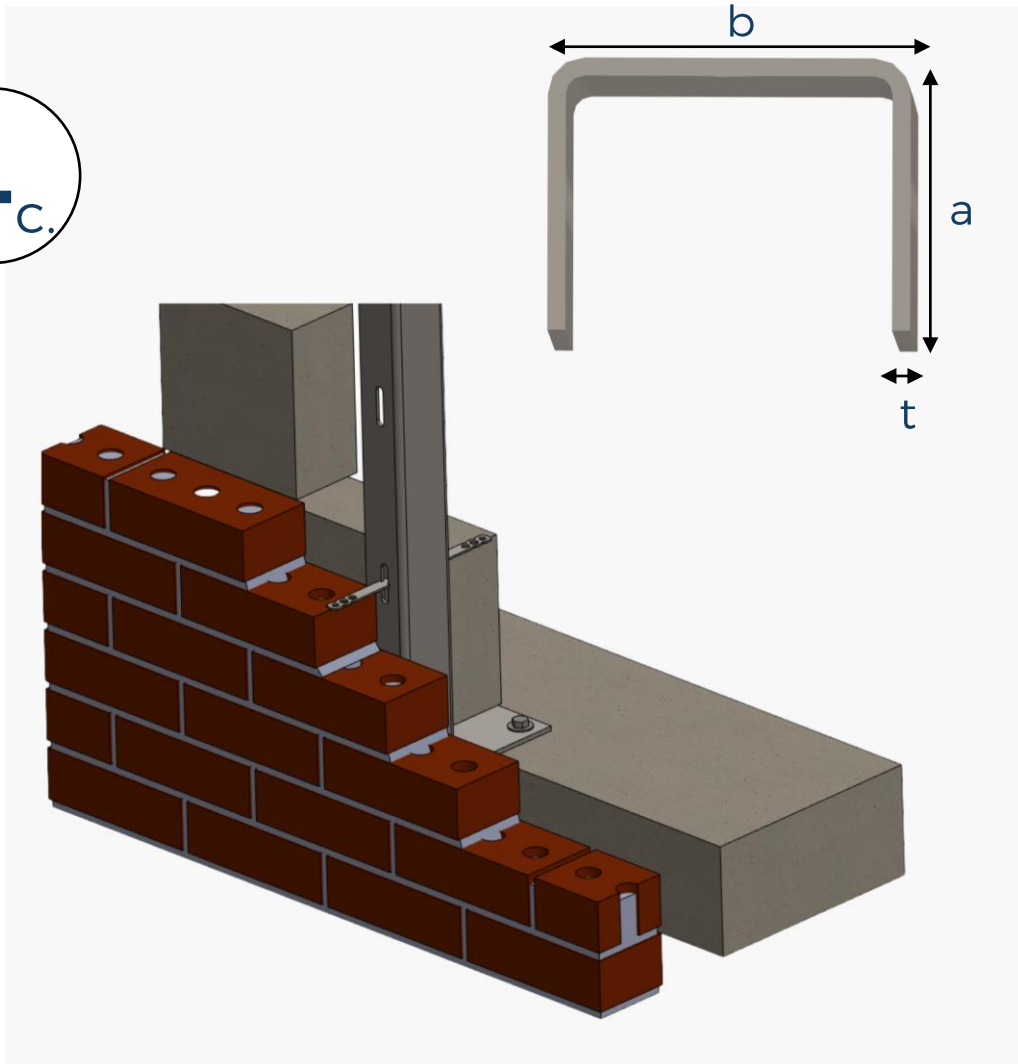

Almost any size of Box profile, L Profile or C Profile can be designed to be used as a parapet windpost. This windpost acts as a cantilever and data on these cantilevered loads are shown on the different profiles below.

Stainless Steel Grade 304	
e	200000 MPa
f_y	191 MPa
Deflection limits for Servicability:	
Parapet Post (cantilever): Post height/180	

C Profile Parapet Post			Fixed Base C Profile Parapet Post Height (mm)						
Section	I _{xx}	Z _{xx}	800	1000	1200	1400	1600	1800	2000
(a x b x t)	mm ⁴ x 10 ⁻⁶	mm ³ x 10 ⁻³	Total allowable Ultimate Horizontal Load on Parapet Post (kN)						
55 x 60 x 4 C	0.333	12.10	4.5	4.4	3.1	2.3	1.7	1.4	1.1
55 x 60 x 5 C	0.392	14.24	4.5	5.2	3.6	2.7	2.0	1.6	1.3
65 x 60 x 4 C	0.488	15.02	4.5	5.7	4.5	3.3	2.5	2.0	1.6
65 x 60 x 5 C	0.579	17.80	4.5	6.0	5.4	3.9	3.0	2.4	1.9
75 x 60 x 4 C	0.678	18.08	4.5	6.0	5.8	4.6	3.5	2.8	2.3
75 x 60 x 5 C	0.808	21.54	4.5	6.0	6.9	5.5	4.2	3.3	2.7
85 x 60 x 4 C	0.904	21.28	4.5	6.0	6.8	5.8	4.7	3.7	3.0
85 x 60 x 5 C	1.082	25.45	4.5	6.0	7.5	6.9	5.6	4.5	3.6
95 x 60 x 5 C	1.402	29.52	4.5	6.0	7.5	8.1	7.0	5.8	4.7
105 x 60 x 5 C	1.773	33.77	4.5	6.0	7.5	9.0	8.1	7.2	5.9
115 x 60 x 5 C	2.196	38.19	4.5	6.0	7.5	9.0	9.1	8.1	7.3
115 x 60 x 6 C	2.540	44.17	4.5	6.0	7.5	9.0	10.5	9.4	8.4

Balustrade & Parapet Windpost

When designing parapet windposts at early design stages of a project, the loads on this support post are often viewed independently from the balustrade without giving consideration to the balustrade. Early design involvement on these supports means that balustrade fixing details are considered along with the parapet masonry support meaning a far more seamless and coordinated installation.

5

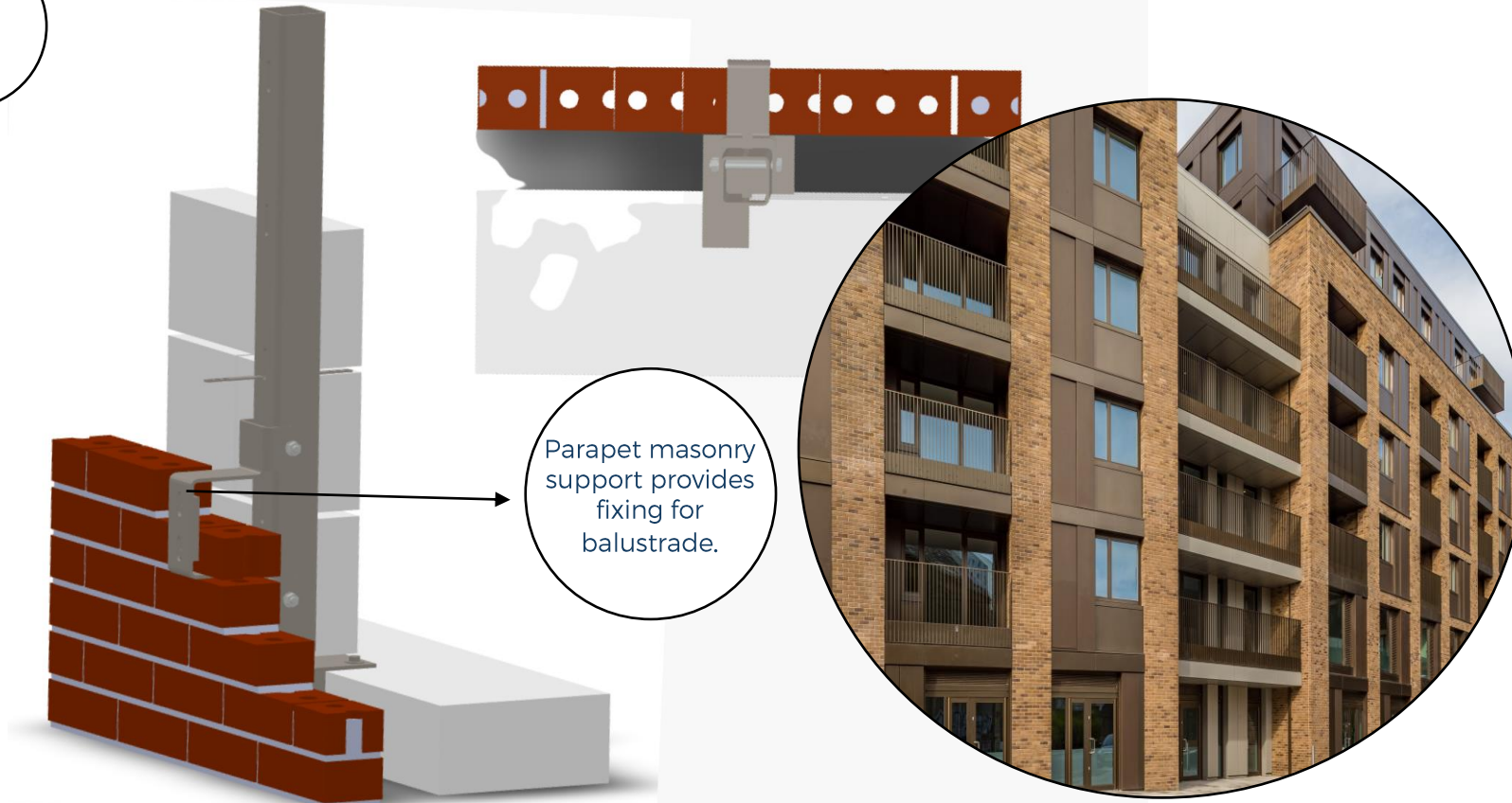

Get in touch

For product information,
or to discuss your project
please **get in touch today:**

Call +44 (0) 1603 722 330

Email info@firma.co.uk

