

COMPACT CHANNEL **KOMPAQDRAIN®**



WHO WE ARE



ULMA Architectural Solutions is a member of the **ULMA Group**, a leading industry group in the Basque Country, and also part of the Industrial Division of the **MONDRAGON Corporation**, one of the largest business corporations in Spain and the largest Cooperative Group in the world.

Our expertise and experience in **prefabricated systems for construction** has led us to develop a wide range of products aimed at **four market** segments:



OUR MATERIAL

COMPRESSIVE STRENGTH

The polymer concrete used in prefabricated systems is capable of withstanding compression forces greater than 1000kg/cm².

FLUID DRAINAGE

The polymeric nature of this material allows smooth surfaces with very low friction on prefabricated elements, thereby facilitating the rapid run-off of fluids and also offering a water absorption index which is virtually non-existent, compared with 5-10% of traditional concrete.

RESISTANCE TO CHEMICAL PRODUCTS

Polyester resin, one of the components of Polymer Concrete, is a material resistant to a very wide range of chemical products; it is an inert material and therefore does not react when it comes into contact with chemical compounds, no matter its concentration.

ABRASIVE WEAR

The hardness of silica aggregates ensures good preservation of structures exposed to road traffic, since polymer concrete shows optimal resistance to abrasion.

IMPACT RESISTANCE

The qualities of this material, together with its optimal prefabrication design, increase its capacity to withstand and absorb impact forces, making it highly resistant.

POLYMER CONCRETE is a **high performance** material made up of a **precise** combination of silica and quartz aggregates bonded by polyester resins.



POLYMER CONCRETE
by **ULMA**

In addition to its **extremely high resistance to compression**, far greater than other traditional concretes, its polymer matrix ensures a high **resistance to most chemical products**. Moreover, the percentage of **water absorption is practically nonexistent**, ensuring its **stability during freeze-thaw cycles**. Its **great impact strength** and **low abrasive wear** are additional features that make polymer concrete the ideal material for the drainage of water and a wide variety of other fluids, even in such demanding environments as the industrial, food, chemical and pharmaceutical sectors.

PHYSICAL PROPERTIES	STANDARD	VALUE
Compressive strength	EN1433	>90 MPa
Resistance to bending	EN1433	>22 MPa
Water absorption	EN 14617-1	0.1%
Resistance to bending after freeze/thaw cycles	EN 14617-5	23.8 MPa
Resistance to abrasive wear	EN 14617-4	32.5 MPa
Resistance to impact	EN 14617-9	5 J
Density	EN 14617-1	2.1 g/cm ³
Resistance to thermal change	EN 14617-6	23.6 MPa
Coefficient of linear thermal expansion	-	2.15-10 ⁻⁵ °C ⁻¹
Resistance to chemicals	EN 14617-10	C4



Compact Channel KOMPAQDRAIN® with Max Flow® system

Specially designed for areas with high traffic density by **ULMA Architectural Solutions**, specialists in drainage system, this novel compact channel made of polymer concrete, is suitable up to load class F900, according to standard EN-1433.

Motorways, airports, service stations and other intense traffic areas require high drainage and maximum safety, requirements to which **KOMPAQDRAIN®** responds with a combination of features that make it unique on the market.

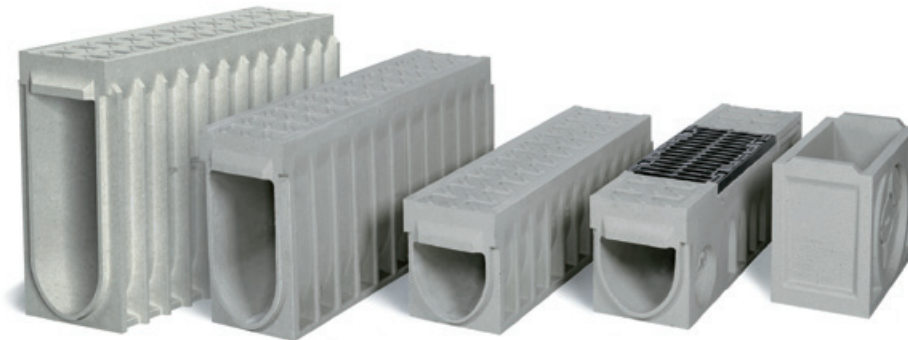

GRATING DESIGNS

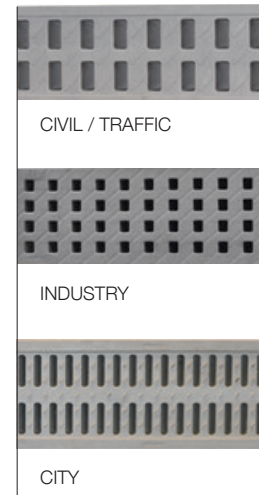

ADVANTAGES OF THE SYSTEM

1. COMPACT
2. LONG-LASTING AND RESISTANT
3. SELF-CLEANING
4. MAXIMUM SECURITY
5. QUICK INSTALLATION

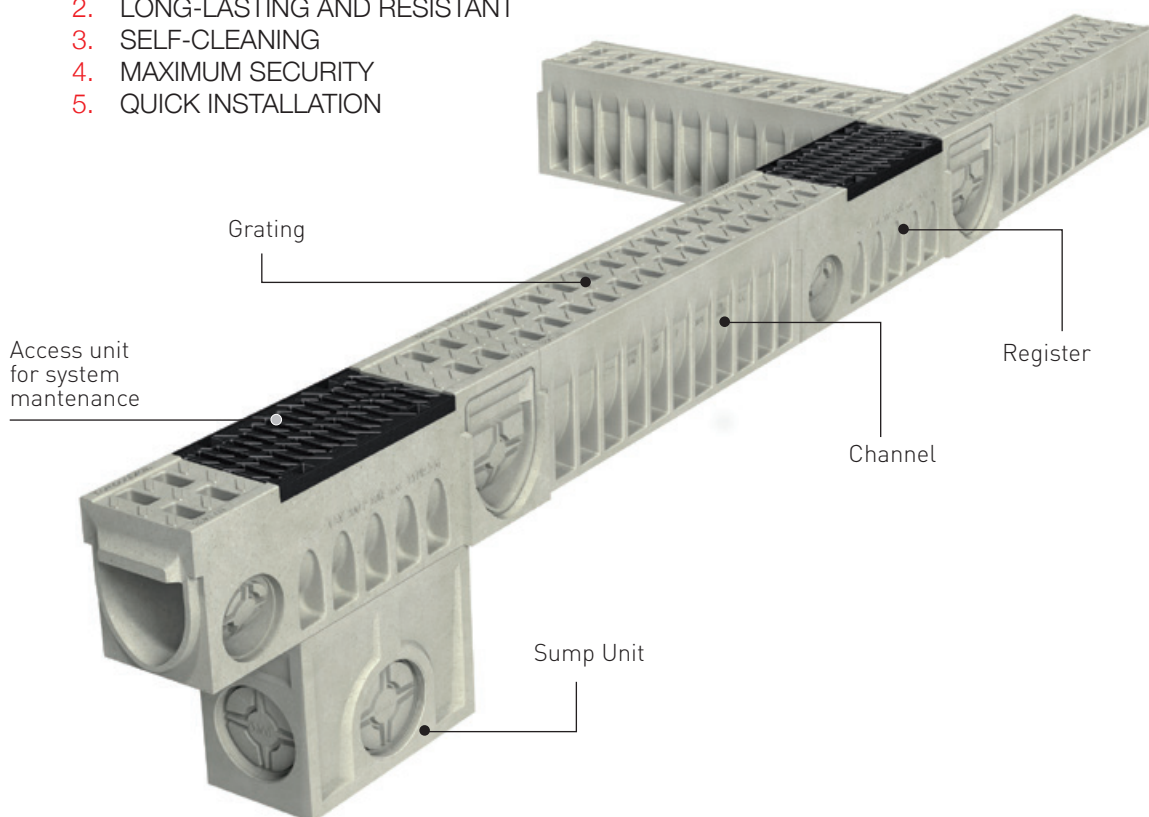

KOMPAQDRAIN®

ADVANTAGES

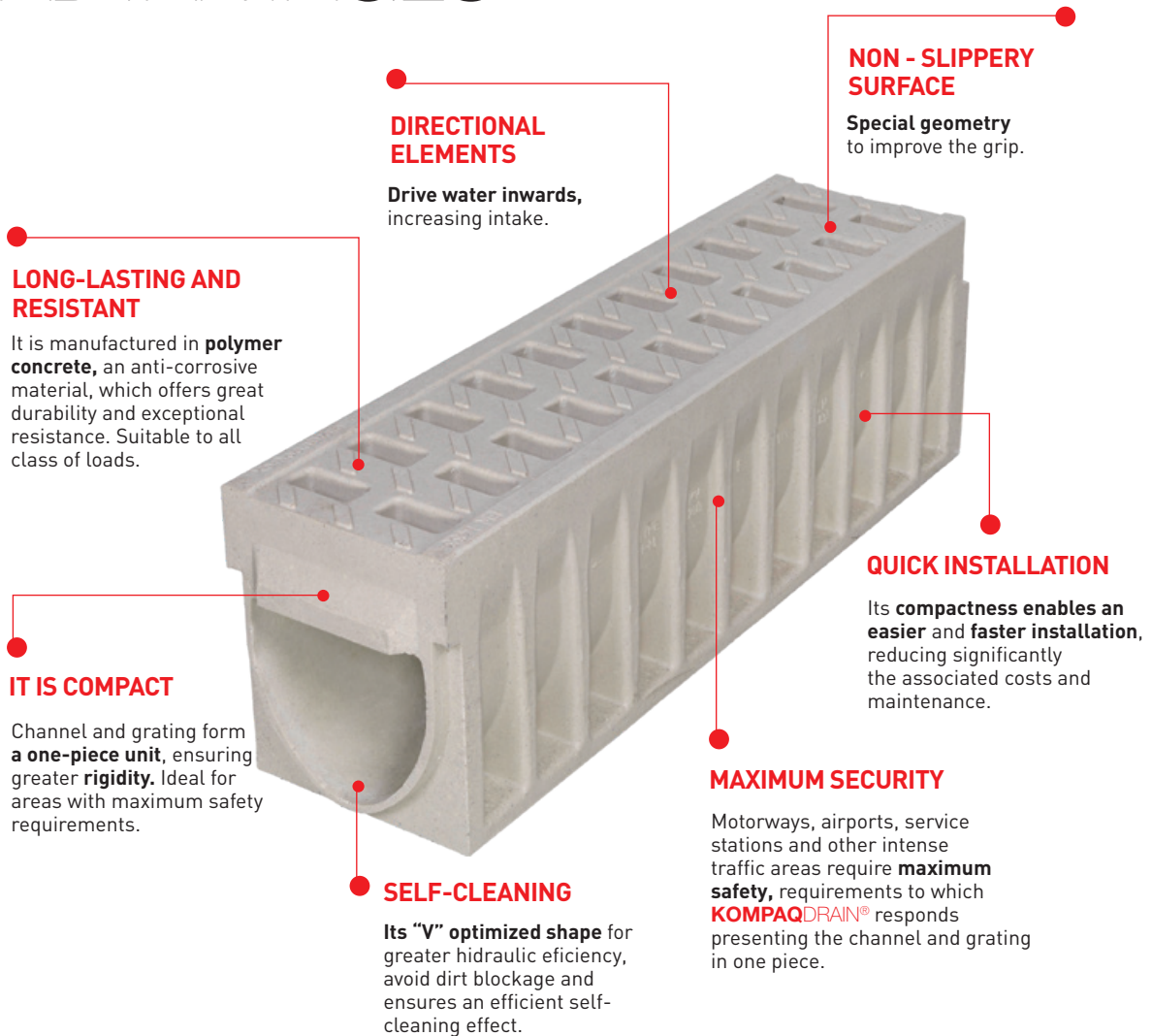

REGISTER

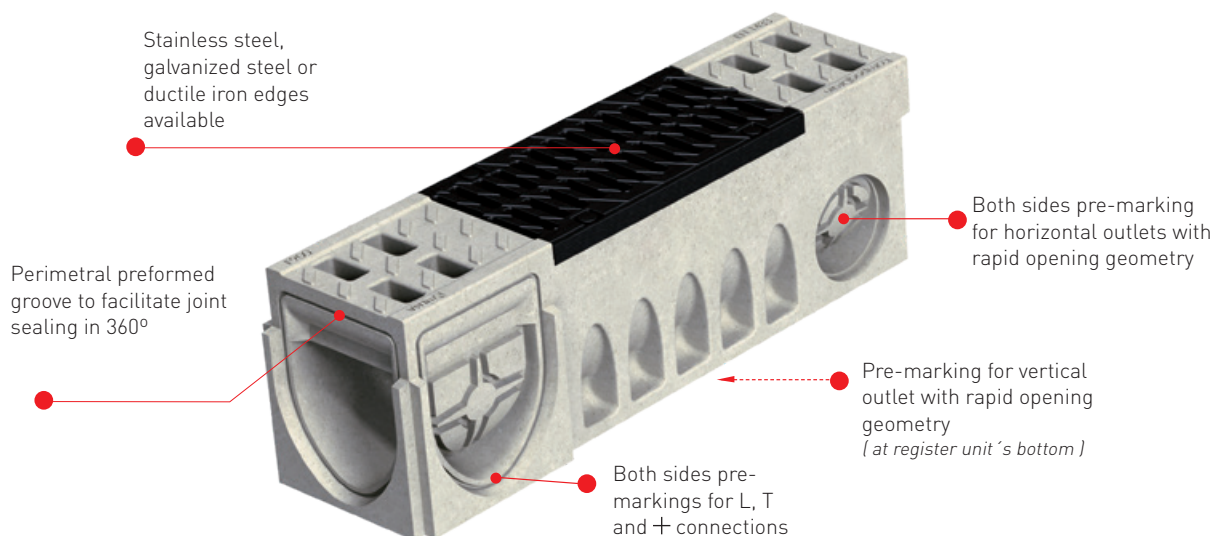

Max Flow[®] SYSTEM

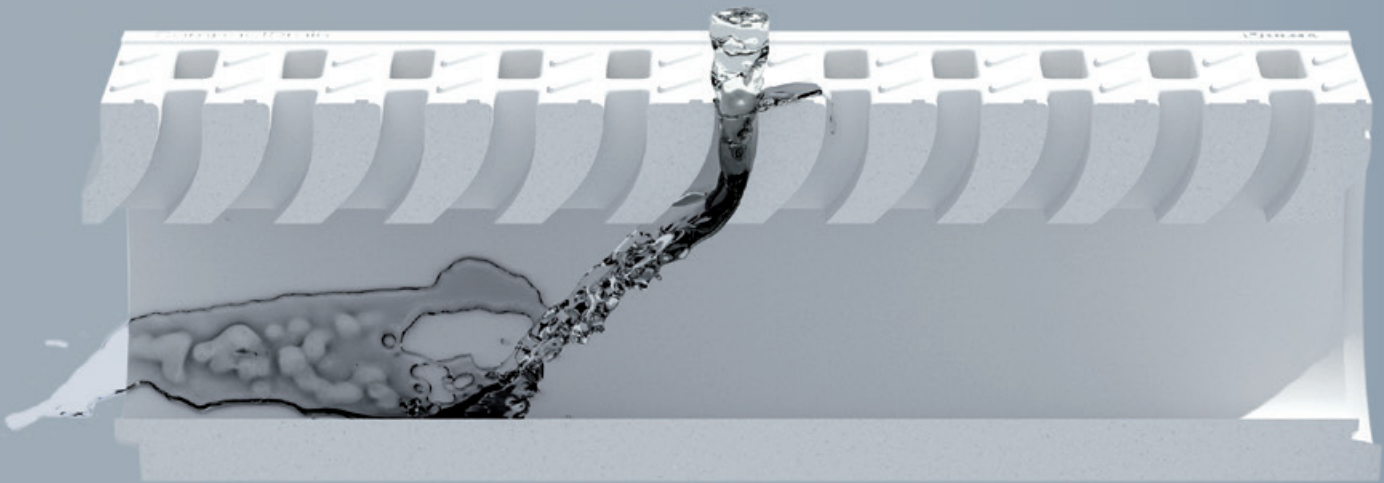

The original curved design of the inlets, together with the non-slip surface and water router, achieve the novel **Max Flow[®]** effect, **increasing the water speed and the drainage capacity**. Moreover, the progressive widening of the orifices helps the waste pass through more easily. Therefore **KOMPAQDRAIN[®]** can drain the same volume of water with a smaller channel.

KOMPAQDRAIN[®] meets all requirements of the EN-1433 international standard of quality and reliability.



// CURVED DESIGN OF THE INLETS

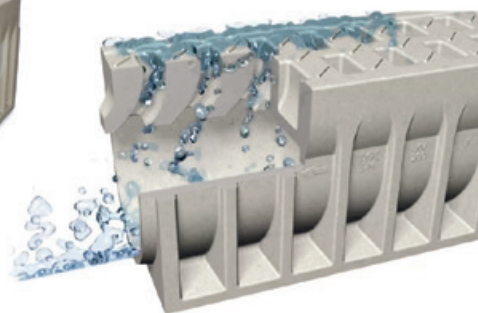

// IT INCREASES THE WATER ENTRY SPEED AND THE DRAINAGE CAPACITY

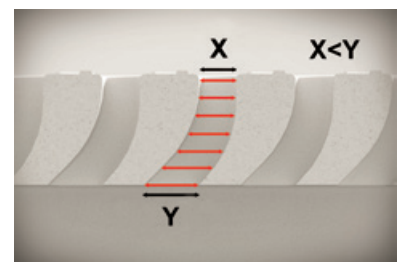

// PROGRESSIVE WIDENING TO PREVENT DIRT BLOCKAGE

KOMPAQDRAIN®

OVERVIEW

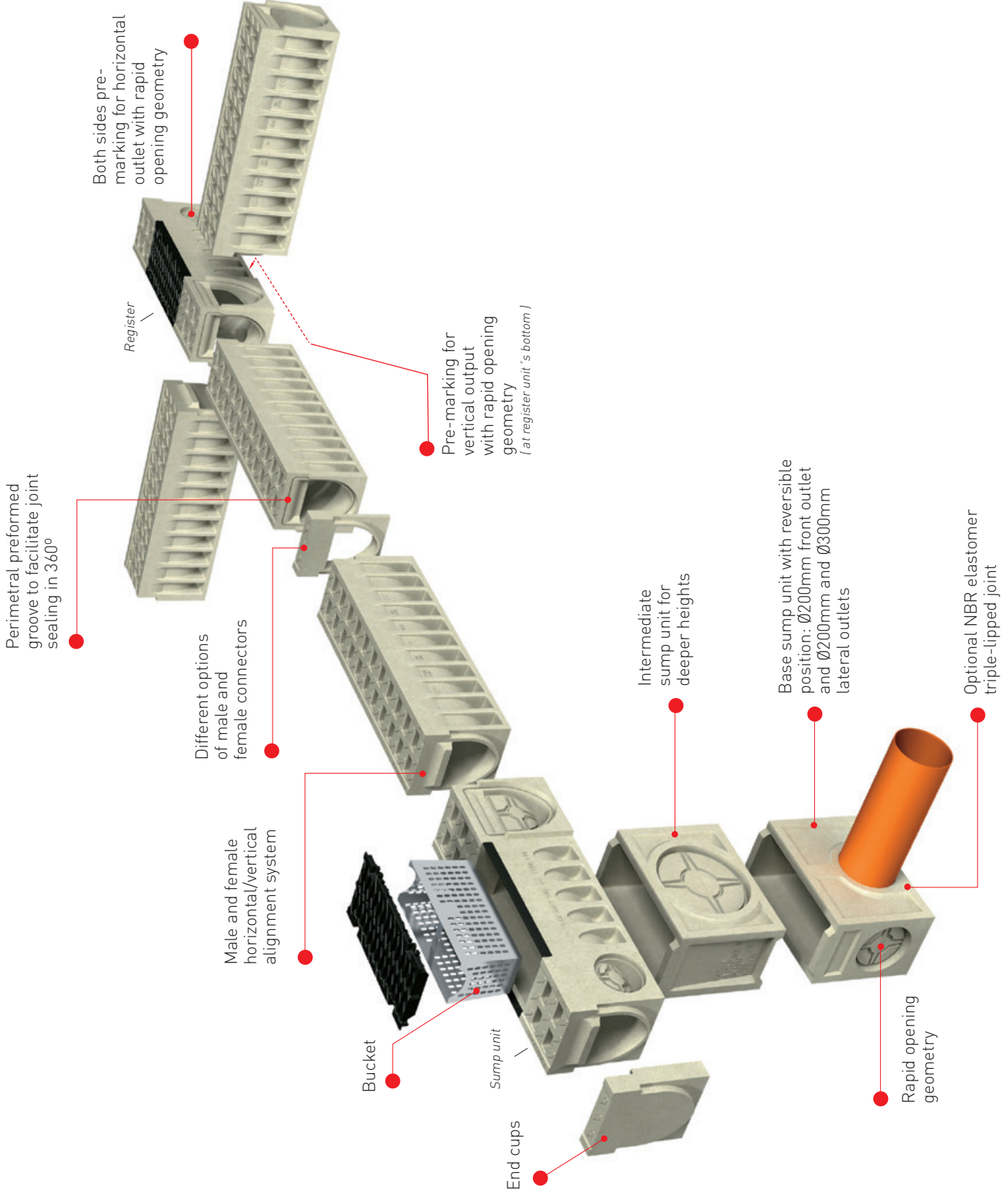

KOMPAQ100 CITY

LOAD CLASS
UP TO **D400**
EN-1433 STANDARD



Linear Drainage Channel model **ULMA KompaqDrain® City KVDH100**, with an integral grating, presented in one-piece and manufactured by high resistant Polymer Concrete. Vandal – proof and corrosion resistant. Load class up to D-400, for all type of vehicles crossing and with reduced capture holes of 8 mm. With "V" optimized shaped and capture holes with MAX-FLOW® geometry: self-cleaning effect at a low flow, increase at maximum flow and positive opening in order to avoid dirt blockage, for areas

without slope. Active surface for cutting of water sheet and for its driving to uptake holes and with non-slippery protuberances. Male and female horizontal and vertical alignment and perimetral preformed groove to facilitate joint sealing in 360°.

The register and the sump unit include: cast iron grating FNHX100FTDM, lateral preforms for horizontal outlets on each side and lateral preforms for connections in T, L and in cross.

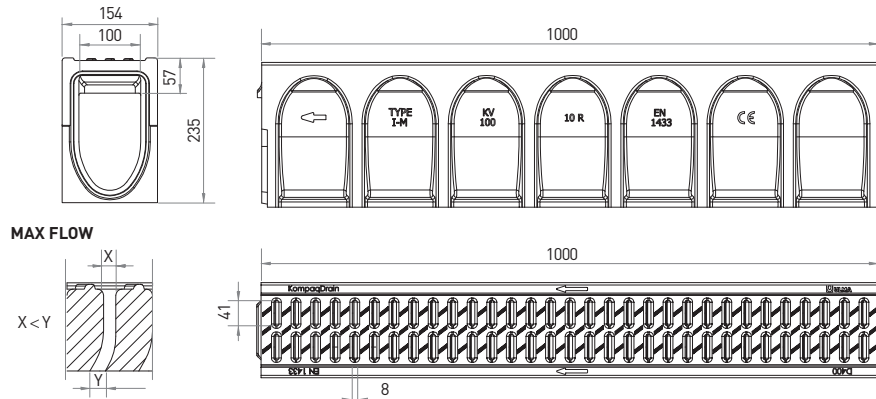
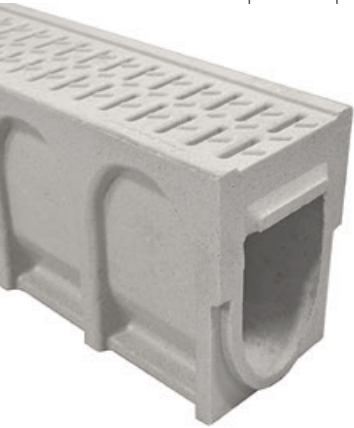

CHANNELS

Channel Code	Length (mm)	Height (mm)	Channel width (mm)		Weight (Kg)	Hydraul. Section (cm ²)	Pcs. (x pallet)
			External	Internal			
KVDH100.10R	1000	235	154	100	32,6	139,5	28

REGISTERS

Channel Code	L. (mm)	Height (mm)	Channel width (mm)		Lateral Outlet (mm)	Vertical Outlet (mm)	T and + channel connection	Weight (Kg)	Hydraul. Section (cm ²)	Pcs. (x pallet)
			Ext.	Int.						
AKVDH100MF10R	1000	235	154	100	110 110	110	YES	40	139,5	28

* Standard cast iron edges, galvanized and stainless steel edges available.

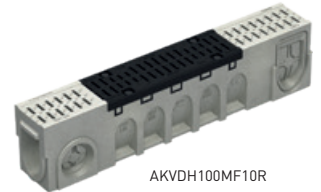

AKVDH100MF10R

SUMP UNITS

Sump Unit Code	L. (mm)	Height (mm)	Channel width (mm)		Frontal Outlet (mm)	Lateral Outlet (mm)	Galvanized steel bucket	Weight (Kg)	Hydraul. Section (cm ²)	Pcs. (x pallet)
			Ext.	Int.						
AKVDH100MF10RS	1000	235	154	100	-	110 110	-	139,5	28	
AKVD100I	500	260	154	100	110	160 110	CKV100	17	-	24
AKVD100B	500	260	154	100	110	160 110	CKV100	19	-	24

** The Sump unit can be higher incorporating an intermediate unit of 260 mm. AKVD100I

*** More info about sump units and registers on page 8.

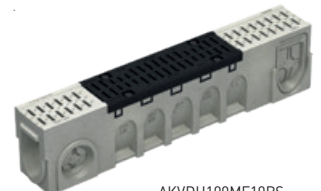

AKVDH100MF10RS



AKVD100B

END CAPS

Channel	Code	∅ (mm)
KVDH100.10R	TKVDH100.10RC	-
	TKVDH100.10RAJ	90



RAJ

CONNECTORS

Channel	Code
KVDH100.10R	TCKVDH100.10RFFA
	TCKVDH100.10RMMA



FFA

MMA

BUCKET

Code
CKV100



SLOPE DESIGNS



WITHOUT SLOPE

SUMP UNITS

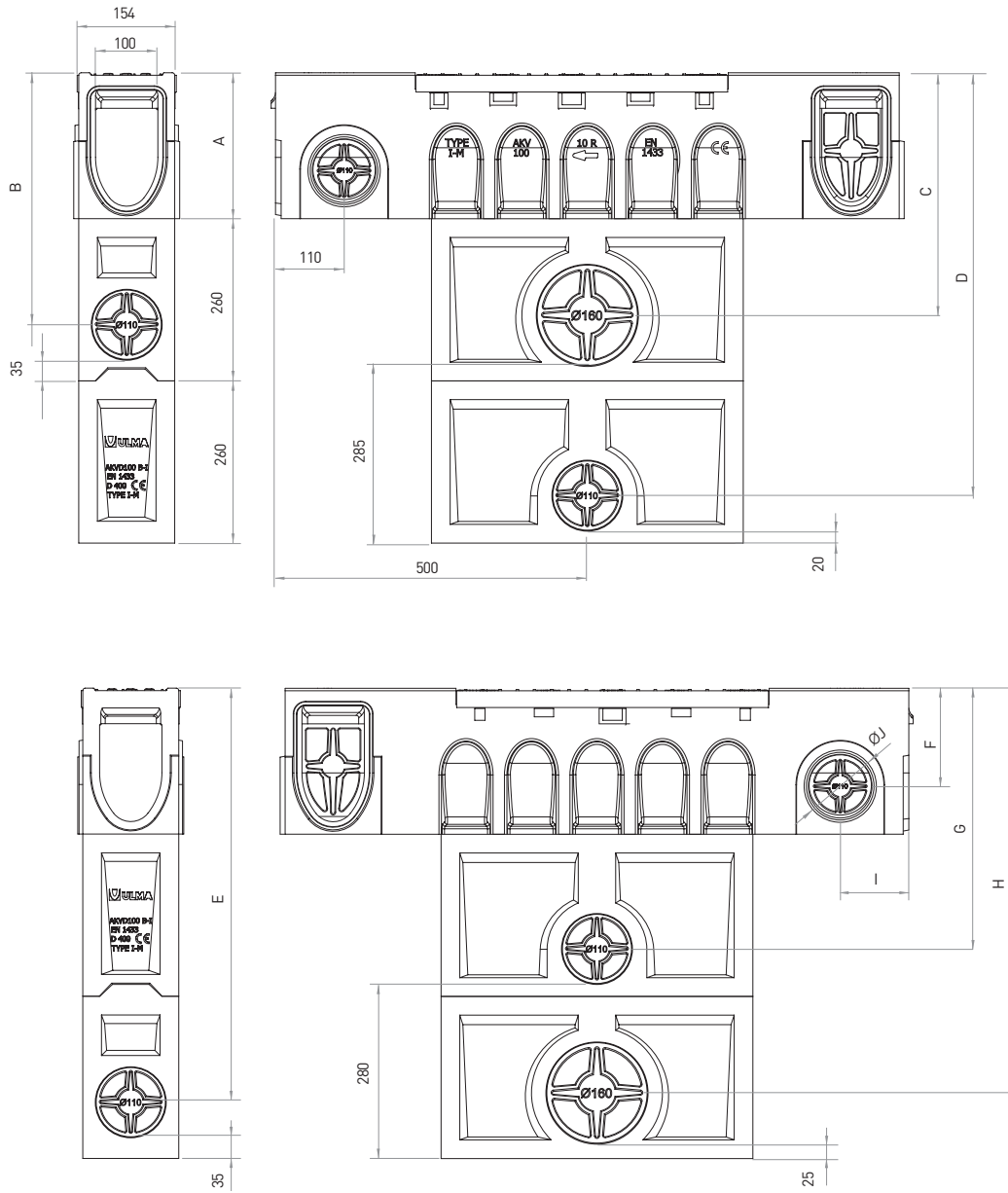

SUMP UNITS SUPERIOR	A	B	C	D	E	F	G	H	I	J
AKVDH100MF10RS	235	403	388	677	663	157	417	648	110	110

KOMPAQ150 CITY

LOAD CLASS
UP TO **D400**
EN-1433 STANDARD



Linear Drainage Channel model **ULMA KompaqDrain® City KVFDH150**, with an integral grating, presented in one-piece and manufactured by high resistant Polymer Concrete. Vandal – proof and corrosion resistant. Load class up to D-400, for all type of vehicles crossing and with reduced capture holes of 13 mm. With "V" optimized shaped and capture holes with MAX-FLOW® geometry: self-cleaning effect at a low flow, increase at maximum flow and positive opening in order to avoid dirt blockage, for areas

without slope. Active surface for cutting of water sheet and for its driving to uptake holes and with non-slippery protuberances. Male and female horizontal and vertical alignment and perimetral preformed groove to facilitate joint sealing in 360°. The register and the sump unit include: cast iron grating FNHX150FTDM, lateral preforms for horizontal outlets on each side and lateral preforms for connections in T, L and in cross.

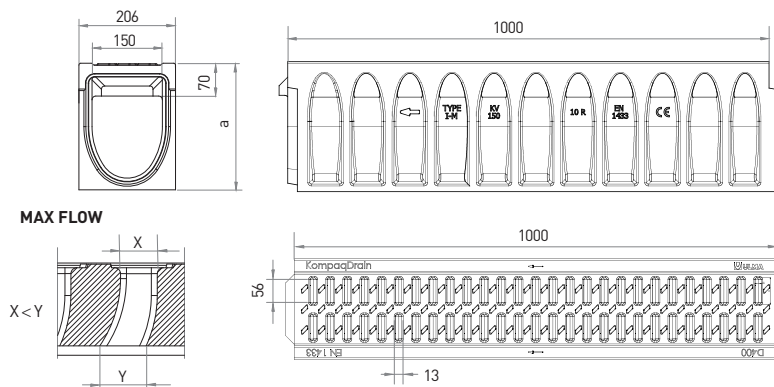

CHANNELS

Channel Code	Length (mm)	Height (mm)	Channel width (mm)		Weigth (Kg)	Hydraul. Section (cm ²)	Pcs. (x pallet)
			External	Internal			
KVFDH150.10R	1000	270	206	150	60	227	15
KVFDH150.20R	1000	370	206	150	70	377	15
KVFDH150.30R	1000	470	206	150	79	527	10

REGISTERS

Channel Code	L. (mm)	Height (mm)	Channel width (mm)		Lateral Outlet (mm)	Vertical Outlet (mm)	T and + channel connection	Weigth (Kg)	Hydraul. Section (cm ²)	Pcs. (x pallet)
			Ext.	Int.						
AKVFDH150MF10R	1000	270	206	150	160 160	160	YES	61	227	12
AKVFDH150MF20R	1000	370	206	150	315 200	160	YES	71	377	12
AKVFDH150MF30R	1000	470	206	150	315 315	160	YES	80	527	8

* Standard cast iron edges, galvanized and stainless steel edges available.



AKVFDH150MF10R

SUMP UNITS

Sump Unit Code	L. (mm)	Height (mm)	Channel width (mm)		Frontal Outlet (mm)	Lateral Outlet (mm)	Galvanized steel bucket	Weigth (Kg)	Hydraul. Section (cm ²)	Pcs. (x pallet)
			Ext.	Int.						
AKVFDH150MF10RS	1000	270	206	150	-	160 160	-	58	227	12
AKVFDH150MF20RS	1000	370	206	150	-	315 200	-	67	377	12
AKVFDH150MF30RS	1000	470	206	150	-	315 315	-	76	527	8
AKVF150I	500	380	206	150	160	200 315	CKV150	30	-	16
AKVF150B	500	380	206	150	160	200 315	CKV150	33	-	16

** The Sump unit can be higher incorporating an intermediate unit of 380 mm. AKVF150I

*** More info about sump units and registers on page 13.



AKVFDH150MF20RS



AKVF150B

END CAPS

Channel	Code	Ø (mm)
KVFDH150.10R	TKVFDH150.10RC	-
	TKVFDH150.10RAJ	110
KVFDH150.20R	TKVFDH150.20RC	-
	TKVFDH150.20RAJ	110
KVFDH150.30R	TKVFDH150.30RC	-
	TKVFDH150.30RAJ	110



RAJ

CONNECTORS

Channel	Code
KVFDH150.10R	TCKVFDH150.10RFFA
	TCKVFDH150.10RMMA
KVFDH150.20R	TCKVFDH150.20RFFA
	TCKVFDH150.20RMMA
KVFDH150.30R	TCKVFDH150.30RFFA
	TCKVFDH150.30RMMA



MMA

BUCKET

Code
CKV150



STEP UNIT

Code
CEKV150



SLOPE DESIGNS



WITHOUT SLOPE

CASCADED SLOPE

KOMPAQ150 TRAFFIC

LOAD CLASS
UP TO **D400**
EN-1433 STANDARD



Linear Drainage Channel model **ULMA KompaqDrain® Traffic KVFD150**, with an integral grating, presented in one-piece and manufactured by high resistant Polymer Concrete. Vandal – proof and corrosion resistant. Load class up to D-400, for all type of vehicles crossing. With “V” optimized shaped and capture holes with MAX-FLOW® geometry: self-cleaning effect at a low flow, increase at maximum flow and positive opening in order to avoid

dirt blockage, for areas without slope. Active surface for cutting of water sheet and for its driving to uptake holes and with non-slippery protuberances. Male and female horizontal and vertical alignment and perimetral preformed groove to facilitate joint sealing in 360°. The register and the sump unit include: cast iron grating FN150FTDM, lateral preforms for horizontal outlets on each side and lateral preforms for connections in T, L and in cross.

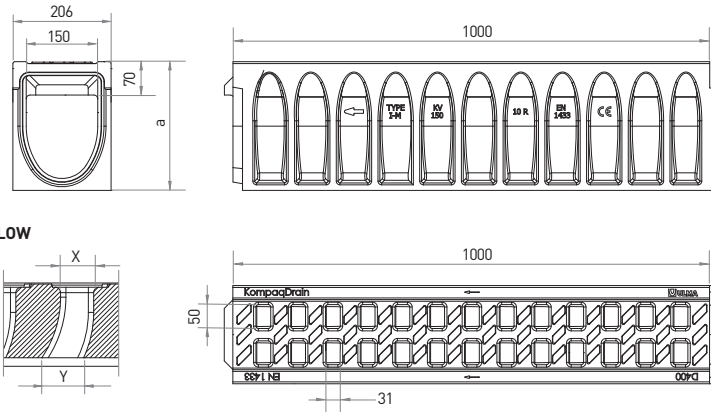

CHANNELS

Channel Code	Length (mm)	Height (mm)	Channel width (mm)		Weigth (Kg)	Hydraul. Section (cm²)	Pcs. (x pallet)
			External	Internal			
KVFD150.10R	1000	270	206	150	57	227	15
KVFD150.20R	1000	370	206	150	67	377	15
KVFD150.30R	1000	470	206	150	78	527	10

REGISTERS

Channel Code	L. (mm)	Height (mm)	Channel width (mm)		Lateral Outlet (mm)	Vertical Outlet (mm)	T and + channel connection	Weigth (Kg)	Hydraul. Section (cm²)	Pcs. (x pallet)	
			Ext.	Int.							
AKVFD150MF10R	1000	270	206	150	160	160	160	YES	57,7	227	12
AKVFD150MF20R	1000	370	206	150	315	200	160	YES	68	377	12
AKVFD150MF30R	1000	470	206	150	315	315	160	YES	79	527	8

* Standard cast iron edges, galvanized and stainless steel edges available.



AKVFD150MF10R

SUMP UNITS

Sump Unit Code	L. (mm)	Height (mm)	Channel width (mm)		Frontal Outlet (mm)	Lateral Outlet (mm)	Galvanized steel bucket	Weigth (Kg)	Hydraul. Section (cm²)	Pcs. (x pallet)	
			Ext.	Int.							
AKVFD150MF10RS	1000	270	206	150	-	160	160	-	54	227	12
AKVFD150MF20RS	1000	370	206	150	-	315	200	-	64	377	12
AKVFD150MF30RS	1000	470	206	150	-	315	315	-	75	527	8
AKVF150I	500	380	206	150	160	200	315	CKV150	30	-	16
AKVF150B	500	380	206	150	160	200	315	CKV150	33	-	16

** The Sump unit can be higher incorporating an intermediate unit of 380 mm. AKVF150I

*** More info about sump units and registers on page 13.



AKVFD150MF10RS



AKVF150B

END CAPS

Channel	Code	Ø (mm)
KVFD150.10R	TKVFD150.10RC	-
	TKVFD150.10RAJ	110
KVFD150.20R	TKVFD150.20RC	-
	TKVFD150.20RAJ	110
KVFD150.30R	TKVFD150.30RC	-
	TKVFD150.30RAJ	110

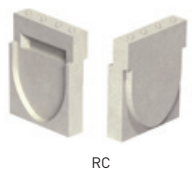

RC



RAJ

CONNECTORS

Channel	Code
KVFD150.10R	TCKVFD150.10RFFA
	TCKVFD150.10RMMA
KVFD150.20R	TCKVFD150.20RFFA
	TCKVFD150.20RMMA
KVFD150.30R	TCKVFD150.30RFFA
	TCKVFD150.30RMMA



FFA



MMA

BUCKET

Code
CKV150



STEP UNIT

Code
CEKV150



SLOPE DESIGNS



WITHOUT SLOPE

CASCADED SLOPE

KOMPAQ150

INDUSTRY

LOAD CLASS
UP TO **E600**
EN-1433 STANDARD



Linear Drainage Channel model **ULMA KompacqDrain® Industry KVE150**, with an integral grating, presented in one-piece and manufactured by high resistant Polymer Concrete. Vandal – proof and corrosion resistant. Load class up to E-600 with surface design without protuberances to avoid vibrations in crossing vehicles, 30 x 25 mm uptake holes. With “V” optimized shaped and capture holes with MAX-FLOW® geometry: self-cleaning effect at a low flow, increase at maximum flow and positive opening in order to avoid dirt

blockage, for areas without slope. Active surface for cutting of water sheet and for its driving to uptake holes. Male and female horizontal and vertical alignment and perimetral preformed groove to facilitate joint sealing in 360°.

The register and the sump unit include: cast iron grating FNX150FTEM, lateral preforms for horizontal outlets on each side and lateral preforms for connections in T, L and in cross.

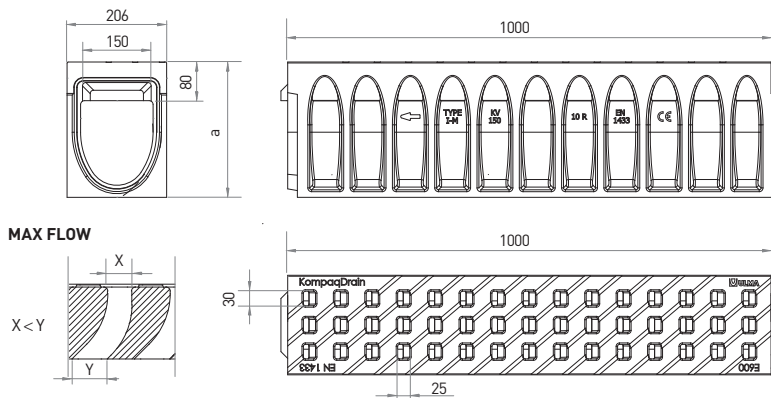
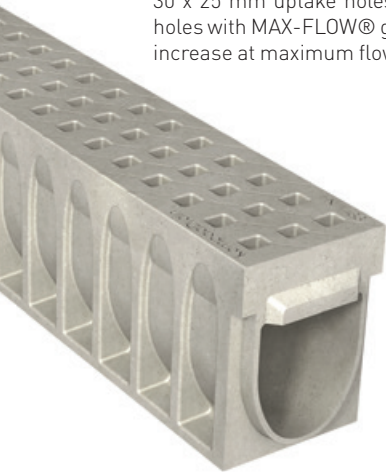

CHANNELS

Channel Code	Length (mm)	Height (mm)	Channel width (mm)		Weight (Kg)	Hydraul. Section (cm²)	Pcs. (x pallet)
			External	Internal			
KVE150.10R	1000	280	206	150	59	227	15
KVE150.20R	1000	380	206	150	69	377	15
KVE150.30R	1000	480	206	150	80	527	10

REGISTERS

Channel Code	L. (mm)	Height (mm)	Channel width (mm)		Lateral Outlet (mm)	Vertical Outlet (mm)	T and + channel connection	Weight (Kg)	Hydraul. Section (cm²)	Pcs. (x pallet)
			Ext.	Int.						
AKVE150MF10R	1000	280	206	150	160	160	160	59	227	12
AKVE150MF20R	1000	380	206	150	315	200	160	70	377	12
AKVE150MF30R	1000	480	206	150	315	315	160	80	527	8

* Standard cast iron edges, galvanized and stainless steel edges available.



AKVE150MF10R

SUMP UNITS

Sump Unit Code	L. (mm)	Height (mm)	Channel width (mm)		Frontal Outlet (mm)	Lateral Outlet (mm)	Galvanized steel bucket	Weight (Kg)	Hydraul. Section (cm²)	Pcs. (x pallet)
			Ext.	Int.						
AKVE150MF10RS	500	280	206	150	-	160	160	-	228	12
AKVE150MF20RS	500	380	206	150	-	315	200	-	379	12
AKVE150MF30RS	500	480	206	150	-	315	315	-	530	8
AKVF150I	500	380	206	150	160	200	315	CKV150	30	16
AKVF150B	500	380	206	150	160	200	315	CKV150	33	16

** The Sump unit can be higher incorporating an intermediate unit of 380 mm. AKVF150I

*** More info about sump units and registers on page 13.



AKVE150MF10RS

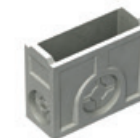

AKVF150B

END CAPS

Channel	Code	∅ (mm)
KVE150.10R	TKVE150.10RC	-
	TKVE150.10RAJ	110
KVE150.20R	TKVE150.20RC	-
	TKVE150.20RAJ	110
KVE150.30R	TKVE150.30RC	-
	TKVE150.30RAJ	110



RC



RAJ

CONNECTORS

Channel	Code
KVE150.10R	TCKVE150.10RFFA
	TCKVE150.10RMMA
KVE150.20R	TCKVE150.20RFFA
	TCKVE150.20RMMA
KVE150.30R	TCKVE150.30RFFA
	TCKVE150.30RMMA



FFA

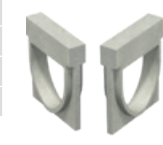

MMA

BUCKET

Code
CKV150



STEP UNIT

Code
CEKV150



SLOPE DESIGNS



WITHOUT SLOPE

CASCADED SLOPE

KOMPAQ150 CIVIL

LOAD CLASS
UP TO **F900**
EN-1433 STANDARD



Linear Drainage Channel model **ULMA KompaqDrain® Civil KVF150**, with an integral grating, presented in one-piece and manufactured by high resistant Polymer Concrete. Vandal – proof and corrosion resistant.

Load class up to F-900, for heavy loads. With "V" optimized shaped and capture holes with MAX-FLOW® geometry: self-cleaning effect at a low flow, increase at maximum flow and positive opening in order to avoid dirt blockage, for areas without slope. Active surface

for cutting of water sheet and for its driving to uptake holes and with non-slippery protuberances. Male and female horizontal and vertical alignment and perimetral preformed groove to facilitate joint sealing in 360°.

The register and the sump unit include: cast iron grating FN150FTFM, lateral preforms for horizontal outlets on each side and lateral preforms for connections in T, L and in cross.

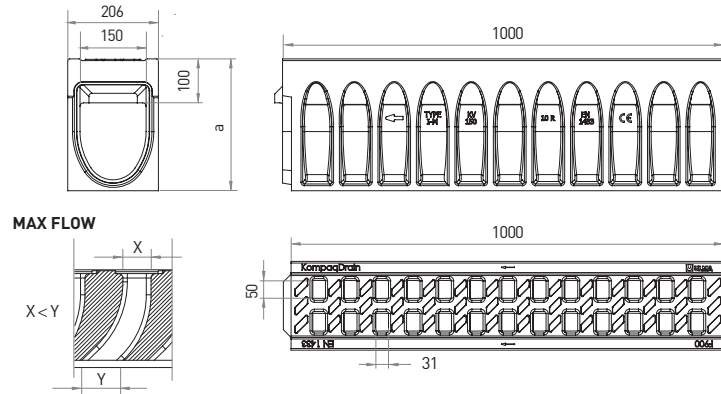

CHANNELS

Channel Code	Length (mm)	Height (mm)	Channel width (mm)		Weight (Kg)	Hydraul. Section (cm ²)	Pcs. (x pallet)
			External	Internal			
KVF150.10R	1000	300	206	150	65	227	12
KVF150.20R	1000	400	206	150	75	377	12
KVF150.30R	1000	500	206	150	84	527	8

REGISTERS

Channel Code	L. (mm)	Height (mm)	Channel width (mm)		Lateral Outlet (mm)	Vertical Outlet (mm)	T and + channel connection	Weight (Kg)	Hydraul. Section (cm ²)	Pcs. (x pallet)
			Ext.	Int.						
AKVF150MF10R	1000	300	206	150	160 160	160	YES	69	227	15
AKVF150MF20R	1000	400	206	150	200 200	160	YES	79	377	15
AKVF150MF30R	1000	500	206	150	315 315	160	YES	89	527	10

* Standard cast iron edges, galvanized and stainless steel edges available.



SUMP UNITS

Sump Unit Code	L. (mm)	Height (mm)	Channel width (mm)		Frontal Outlet (mm)	Lateral Outlet (mm)	Galvanized steel bucket	Weight (Kg)	Hydraul. Section (cm ²)	Pcs. (x pallet)
			Ext.	Int.						
AKVF150MF10RS	1000	300	206	150	-	160 160	-	66	227	12
AKVF150MF20RS	1000	400	206	150	-	315 200	-	76	377	12
AKVF150MF30RS	1000	500	206	150	-	315 315	-	86	527	8
AKVF150I	500	380	206	150	160	200 315	CKV150	30	-	16
AKVF150B	500	380	206	150	160	200 315	CKV150	33	-	16

** The Sump unit can be higher incorporating an intermediate unit of 380 mm. AKVF150I

*** More info about sump units and registers on page 13.



END CAPS

Channel	Code	Ø (mm)
KVF150.10R	TKVF150.10RC	-
	TKVF150.10RAJ	110
KVF150.20R	TKVF150.20RC	-
	TKVF150.20RAJ	110
KVF150.30R	TKVF150.30RC	-
	TKVF150.30RAJ	110

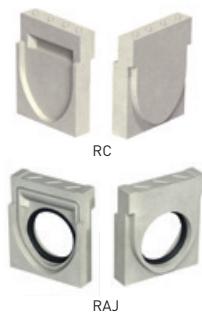

CONNECTORS

Channel	Code
KVF150.10R	TCKVF150.10RFFA
	TCKVF150.10RMMA
KVF150.20R	TCKVF150.20RFFA
	TCKVF150.20RMMA
KVF150.30R	TCKVF150.30RFFA
	TCKVF150.30RMMA



BUCKET

Code
CKV150



STEP UNIT

Code
CEKV150



SLOPE DESIGNS



SUMP UNITS

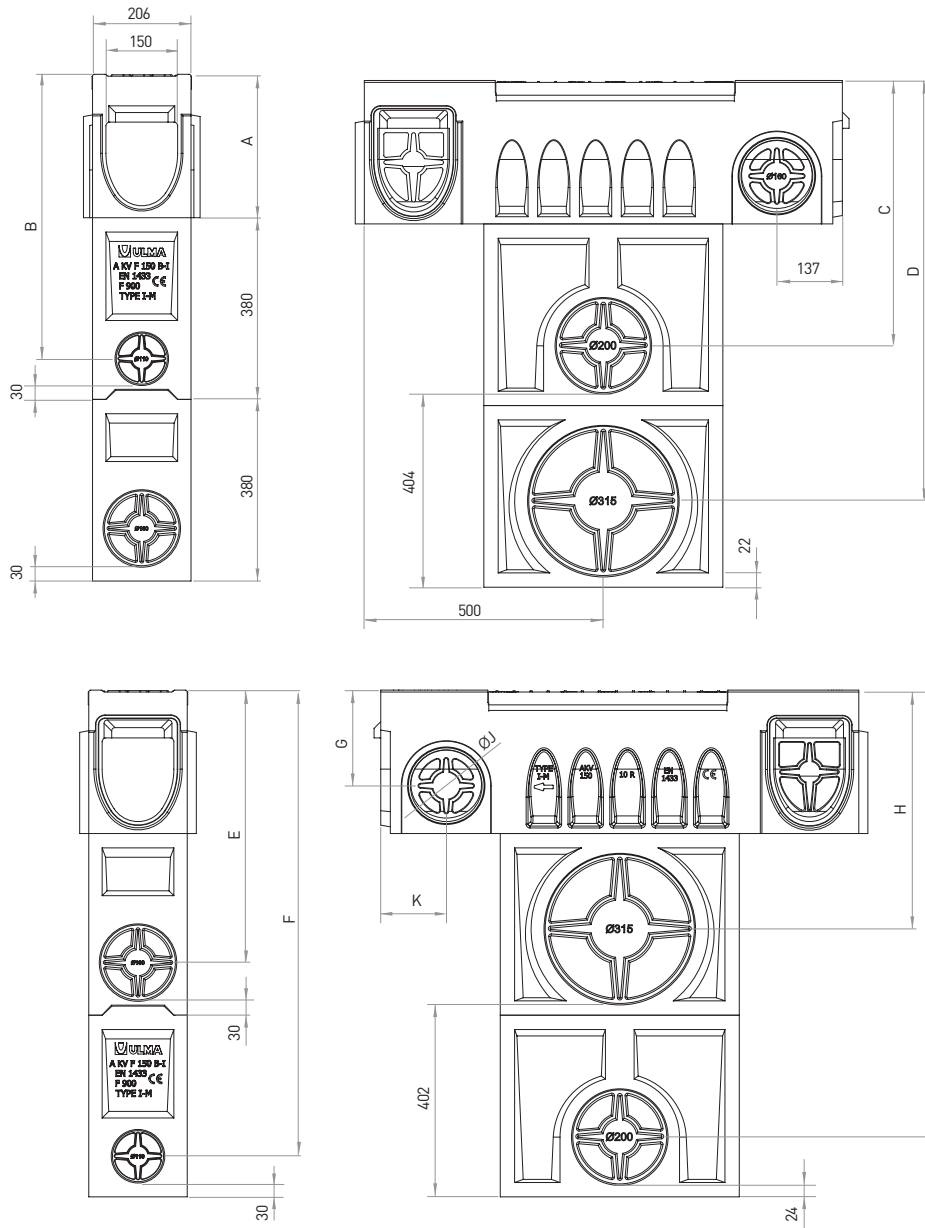

	SUMP UNITS SUPERIOR	A	B	C	D	E	F	G	H	I	J	K
CITY	AKVFDH150MF10RS	270	564	523	848	539	944	170	469	903	160	137
	AKVFDH150MF20RS	370	664	623	948	639	1044	250	569	1003	200	162
	AKVFDH150MF30RS	470	764	723	1048	739	1144	291	669	1103	315	203
TRAFFIC	AKVFD150MF10RS	270	564	523	848	539	944	170	469	903	160	137
	AKVFD150MF20RS	370	664	623	948	639	1044	250	569	1003	200	162
	AKVFD150MF30RS	470	764	723	1048	739	1144	291	669	1103	315	203
INDUSTRY	AKVE150MF10RS	280	574	533	858	549	954	180	479	913	160	137
	AKVE150MF20RS	380	674	633	958	649	1054	260	579	1013	200	162
	AKVE150MF30RS	480	774	733	1058	749	1154	301	679	1113	315	203
CIVIL	AKVF150MF10RS	300	594	553	878	569	974	200	499	933	160	137
	AKVF150MF20RS	400	694	653	978	669	1074	280	599	1033	200	162
	AKVF150MF30RS	500	794	753	1078	769	1174	321	699	1133	315	203

KOMPAQ200

CITY

LOAD CLASS
UP TO **D400**
EN-1433 STANDARD



Linear Drainage Channel model **ULMA KompaqDrain® City KVFDH200** with an integral grating, presented in one-piece and manufactured by high resistant Polymer Concrete. Vandal – proof and corrosion resistant. Load class up to D-400, for all type of vehicles crossing and with reduced capture holes of 16mm. With “V” optimized shaped and capture holes with MAX-FLOW® geometry: self-cleaning effect at a low flow, increase at maximum flow and positive opening in order to avoid dirt blockage, for areas without

slope. Active surface for cutting of water sheet and for its driving to uptake holes and with non-slippery protuberances. Male and female horizontal and vertical alignment and perimetral preformed groove to facilitate joint sealing in 360°.

The register and the sump unit include: cast iron grating FNX200FTDM, lateral preforms for horizontal outlets on each side and lateral preforms for connections in T, L and in cross.

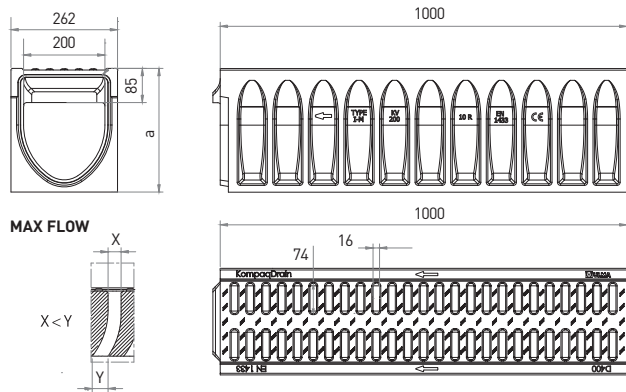

CHANNELS

Channel Code	Length (mm)	Height (mm)	Channel width (mm)		Weight (Kg)	Hydraul. Section (cm ²)	Pcs. (x pallet)
			External	Internal			
KVFDH200.10R	1000	305	262	200	79	318	12
KVFDH200.30R	1000	505	262	200	101	718	8
KVFDH200.50R	1000	705	262	200	131	1118	8

REGISTERS

Channel Code	L. (mm)	Height (mm)	Channel width (mm)		Lateral Outlet (mm)	Vertical Outlet (mm)	T and + channel connection	Weight (Kg)	Hydraul. Section (cm ²)	Pcs. (x pallet)
			Ext.	Int.						
AKVFDH200MF10R	1000	305	262	200	160	160	160	81	318	12
AKVFDH200MF30R	1000	505	262	200	315	315	200	105	718	8
AKVFDH200MF50R	1000	705	262	200	400	400	200	135	1118	8

* Standard cast iron edges, galvanized and stainless steel edges available.



AKVFDH200MF10R

SUMP UNITS

Sump Unit Code	L. (mm)	Height (mm)	Channel width (mm)		Frontal Outlet (mm)	Lateral Outlet (mm)	Galvanized steel bucket	Weight (Kg)	Hydraul. Section (cm ²)	Pcs. (x pallet)	
			Ext.	Int.							
AKVFDH200MF10RS	1000	305	262	200	-	160	160	-	75	318	12
AKVFDH200MF30RS	1000	505	262	200	-	315	315	-	99	718	8
AKVFDH200MF50RS	1000	705	262	200	-	400	400	-	129	1118	8
AKVF200I	500	380	262	200	200	200	315	CKV200	34	-	16
AKVF200B	500	380	262	200	200	200	315	CKV200	38	-	16

** The Sump unit can be higher incorporating an intermediate unit of 380 mm. AKVF200I.

*** More info about sump units and registers on page 18.



AKVFDH200MF10RS



AKVF200B

END CAPS

Channel	Code	Ø (mm)
KVFDH200.10R	TKVFDH200.10RC	-
	TKVFDH200.10RAJ	160
KVFDH200.30R	TKVFDH200.30RC	-
	TKVFDH200.30RAJ	200
KVFDH200.50R	TKVFDH200.50RC	-
	TKVFDH200.50RAJ	400

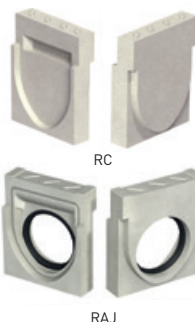

CONNECTORS

Channel	Code
KVFDH200.10R	TCKVFDH200.10RFFA
	TCKVFDH200.10RMMA
KVFDH200.30R	TCKVFDH200.30RFFA
	TCKVFDH200.30RMMA
KVFDH200.50R	TCKVFDH200.50RFFA
	TCKVFDH200.50RMMA



BUCKET

Code
CKV200



STEP UNIT

Code
CEKV200



SLOPE DESIGNS



KOMPAQ200 TRAFFIC

LOAD CLASS
UP TO **D400**
EN-1433 STANDARD



Linear Drainage Channel model **ULMA KompaqDrain® Traffic KVFD200**, with an integral grating, presented in one-piece and manufactured by high resistant Polymer Concrete. Vandal – proof and corrosion resistant. Load class up to D-400, for all type of vehicles crossing. With "V" optimized shaped and capture holes with MAX-FLOW® geometry: self-cleaning effect at a low flow, increase at maximum flow and positive opening in order to avoid

dirt blockage, for areas without slope. Active surface for cutting of water sheet and for its driving to uptake holes and with non-slippery protuberances. Male and female horizontal and vertical alignment and perimetral preformed groove to facilitate joint sealing in 360°. The register and the sump unit include: cast iron grating FNX200FTDM, lateral preforms for horizontal outlets on each side and lateral preforms for connections in T, L and in cross.

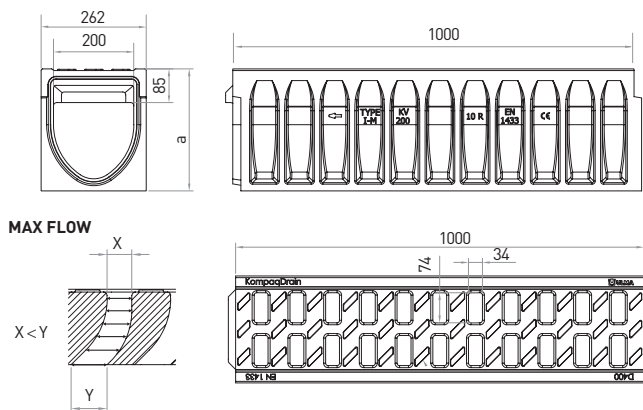

CHANNELS

Channel Code	Length (mm)	Height (mm)	Channel width (mm)		Weigth (Kg)	Hydraul. Section (cm ²)	Pcs. (x pallet)
			External	Internal			
KVFD200.10R	1000	305	262	200	78	318	12
KVFD200.30R	1000	505	262	200	101	718	8
KVFD200.50R	1000	705	262	200	131	1118	8

REGISTERS

Channel Code	L. (mm)	Height (mm)	Channel width (mm)		Lateral Outlet (mm)		Vertical Outlet (mm)	T and + channel connection	Weigth (Kg)	Hydraul. Section (cm ²)	Pcs. (x pallet)
			Ext.	Int.							
AKVFD200MF10R	1000	305	262	200	160	160	160	YES	80	318	12
AKVFD200MF30R	1000	505	262	200	315	315	200	YES	104	718	8
AKVFD200MF50R	1000	705	262	200	400	400	200	YES	135	1118	8

* Standard cast iron edges, galvanized and stainless steel edges available.



SUMP UNITS

Sump Unit Code	L. (mm)	Height (mm)	Channel width (mm)		Frontal Outlet (mm)	Lateral Outlet (mm)	Galvanized steel bucket	Weigth (Kg)	Hydraul. Section (cm ²)	Pcs. (x pallet)	
			Ext.	Int.							
AKVFD200MF10RS	1000	305	262	200	-	160	160	-	74	318	12
AKVFD200MF30RS	1000	505	262	200	-	315	315	-	98	718	8
AKVFD200MF50RS	1000	705	262	200	-	400	400	-	128	1118	8
AKVF200I	500	380	262	200	200	200	315	CKV200	34	-	16
AKVF200B	500	380	262	200	200	200	315	CKV200	38	-	16

** The Sump unit can be higher incorporating an intermediate unit of 380 mm. AKVF200I.

*** More info about sump units and registers on page 18.



END CAPS

Channel	Code	Ø (mm)
KVFD200.10R	TKVFD200.10RC	-
	TKVFD200.10RAJ	160
KVFD200.30R	TKVFD200.30RC	-
	TKVFD200.30RAJ	200
KVFD200.50R	TKVFD200.50RC	-
	TKVFD200.50RAJ	400

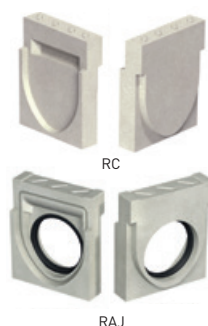

CONNECTORS

Channel	Code
KVFD200.10R	TCKVFD200.10RFFA
	TCKVFD200.10RMMA
KVFD200.30R	TCKVFD200.30RFFA
	TCKVFD200.30RMMA
KVFD200.50R	TCKVFD200.50RFFA
	TCKVFD200.50RMMA



BUCKET

Code
CKV200



STEP UNIT

Code
CEKV200



SLOPE DESIGNS



KOMPAQ200

INDUSTRY

LOAD CLASS
UP TO **E600**
EN-1433 STANDARD



Linear Drainage Channel model **ULMA KompaqDrain® Industry KVE200**, with an integral grating, presented in one-piece and manufactured by high resistant Polymer Concrete. Vandal – proof and corrosion resistant. Load class up to E-600 with surface design without protuberances to avoid vibrations in crossing vehicles, 30 x 25 mm uptake holes. With "V" optimized shaped and capture holes with MAX-FLOW® geometry: self-cleaning effect at a low flow, increase at maximum flow and positive opening in order to avoid dirt

blockage, for areas without slope. Active surface for cutting of water sheet and for its driving to uptake holes. Male and female horizontal and vertical alignment and perimetral preformed groove to facilitate joint sealing in 360°.

The register and the sump unit include: cast iron grating FNX200FTEM, lateral preforms for horizontal outlets on each side and lateral preforms for connections in T, L and in cross.

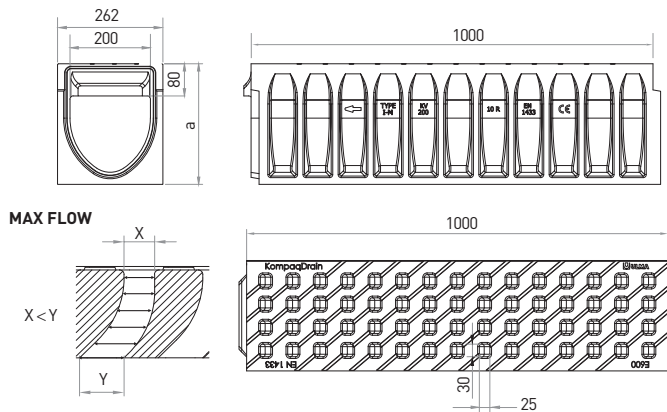
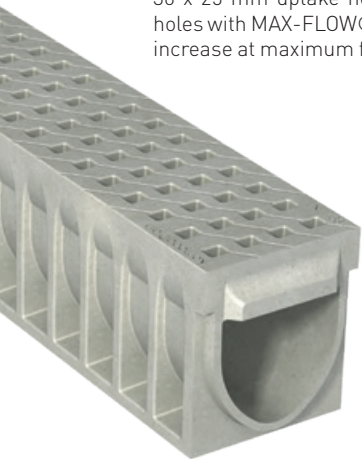

CHANNELS

Channel Code	Length (mm)	Height (mm)	Channel width (mm)		Weight (Kg)	Hydraul. Section (cm²)	Pcs. (x pallet)
			External	Internal			
KVE200.10R	1000	300	262	200	81	318	12
KVE200.30R	1000	500	262	200	104	718	8
KVE200.50R	1000	700	262	200	134	1118	8

REGISTERS

Channel Code	L. (mm)	Height (mm)	Channel width (mm)		Lateral Outlet (mm)	Vertical Outlet (mm)	T and + channel connection	Weight (Kg)	Hydraul. Section (cm²)	Pcs. (x pallet)
			Ext.	Int.						
AKVE200MF10R	1000	300	262	200	160 160	160	YES	82	318	12
AKVE200MF30R	1000	500	262	200	315 315	200	YES	106	718	8
AKVE200MF50R	1000	700	262	200	400 400	200	YES	137	1118	8

* Standard cast iron edges, galvanized and stainless steel edges available.



SUMP UNITS

Sump Unit Code	L. (mm)	Height (mm)	Channel width (mm)		Frontal Outlet (mm)	Lateral Outlet (mm)	Galvanized steel bucket	Weight (Kg)	Hydraul. Section (cm²)	Pcs. (x pallet)
			Ext.	Int.						
AKVE200MF10RS	1000	300	262	200	-	160 160	-	76	318	12
AKVE200MF30RS	1000	500	262	200	-	315 315	-	100	718	8
AKVE200MF50RS	1000	700	262	200	-	400 400	-	130	1118	8
AKVF200I	500	380	262	200	200	200 315	CKV200	34	-	16
AKVF200B	500	380	262	200	200	200 315	CKV200	38	-	16

** The Sump unit can be higher incorporating an intermediate unit of 380 mm. AKVF200I.

*** More info about sump units and registers on page 18.



END CAPS

Channel	Code	Ø (mm)
KVE200.10R	TKVE200.10RC	-
	TKVE200.10RAJ	160
KVE200.30R	TKVE200.30RC	-
	TKVE200.30RAJ	200
KVE200.50R	TKVE200.50RC	-
	TKVE200.50RAJ	400

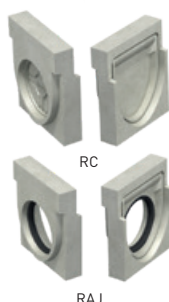

CONNECTORS

Channel	Code
KVE200.10R	TCKVE200.10RFFA
	TCKVE200.10RMMA
KVE200.30R	TCKVE200.30RFFA
	TCKVE200.30RMMA
KVE200.50R	TCKVE200.50RFFA
	TCKVE200.50RMMA



BUCKET

Code
CKV200



STEP UNIT

Code
CEKV200



SLOPE DESIGNS



KOMPAQ200

CIVIL

LOAD CLASS
UP TO **F900**
EN-1433 STANDARD



Linear Drainage Channel model **ULMA KompaqDrain® Civil KVF200**, with an integral grating, presented in one-piece and manufactured by high resistant Polymer Concrete. Vandal – proof and corrosion resistant. Load class up to F-900 for high loads. With “V” optimized shaped and capture holes with MAX-FLOW® geometry: self-cleaning effect at a low flow, increase at maximum flow and positive opening in order to avoid dirt blockage, for areas

without slope. Active surface for cutting of water sheet and for its driving to uptake holes and with non-slippery protuberances. Male and female horizontal and vertical alignment and perimetral preformed groove to facilitate joint sealing in 360°. The register and the sump unit include cast iron grating FNX200FTFM, lateral preforms for horizontal outlets on each side and lateral preforms for connections in T, L and in cross.

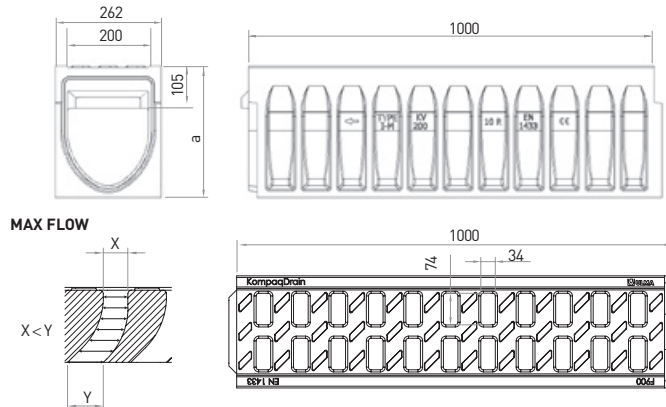

CHANNELS

Channel Code	Length (mm)	Height (mm)	Channel width (mm)		Weigth (Kg)	Hydraul. Section (cm ²)	Pcs. (x pallet)
			External	Internal			
KVF200.10R	1000	325	262	200	88	318	12
KVF200.30R	1000	525	262	200	111	718	8
KVF200.50R	1000	725	262	200	141	1118	8

REGISTERS

Channel Code	L. (mm)	Height (mm)	Channel width (mm)		Lateral Outlet (mm)	Vertical Outlet (mm)	T and + channel connection	Weigth (Kg)	Hydraul. Section (cm ²)	Pcs. (x pallet)
			Ext.	Int.						
AKVF200MF10R	1000	325	262	200	160	160	160	90	318	12
AKVF200MF30R	1000	525	262	200	315	315	200	115	718	8
AKVF200MF50R	1000	725	262	200	400	400	200	145	1118	8



AKVF200MF10R

* Standard cast iron edges, galvanized and stainless steel edges available.

SUMP UNITS

Sump Unit Code	L. (mm)	Height (mm)	Channel width (mm)		Frontal Outlet (mm)	Lateral Outlet (mm)	Galvanized steel bucket	Weigth (Kg)	Hydraul. Section (cm ²)	Pcs. (x pallet)	
			Ext.	Int.							
AKVF200MF10RS	1000	325	262	200	-	160	160	-	84	318	12
AKVF200MF30RS	1000	525	262	200	-	315	315	-	108	718	8
AKVF200MF50RS	1000	725	262	200	-	400	400	-	138	1118	8
AKVF200I	500	380	262	200	200	200	315	CKV200	34	-	16
AKVF200B	500	380	262	200	200	200	315	CKV200	38	-	16



AKVF200MF10RS



AKVF200B

** The Sump unit can be higher incorporating an intermediate unit of 380 mm. AKVF200I.

**** More info about sump units and registers on page 18.

END CAPS

Channel	Code	Ø (mm)
KVF200.10R	TKVF200.10RC	-
	TKVF200.10RAJ	160
KVF200.30R	TKVF200.30RC	-
	TKVF200.30RAJ	200
KVF200.50R	TKVF200.50RC	-
	TKVF200.50RAJ	400

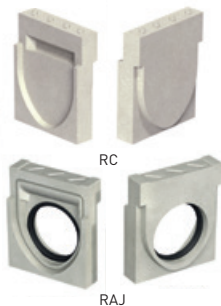

CONNECTORS

Channel	Code
KVF200.10R	TCKVF200.10RFFA
	TCKVF200.10RMMA
KVF200.30R	TCKVF200.30RFFA
	TCKVF200.30RMMA
KVF200.50R	TCKVF200.50RFFA
	TCKVF200.50RMMA



BUCKET

Code
CKV200



STEP UNIT

Code
CEKV200



SLOPE DESIGNS



WITHOUT SLOPE

CASCADED SLOPE

SUMP UNITS

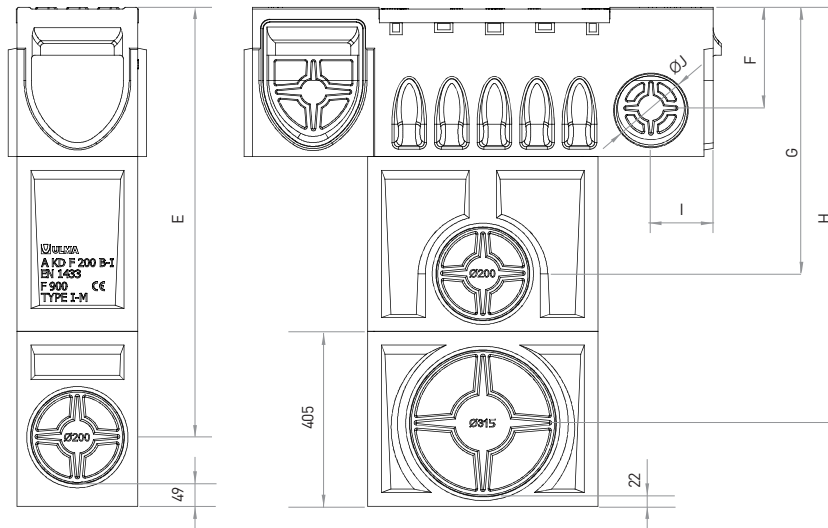
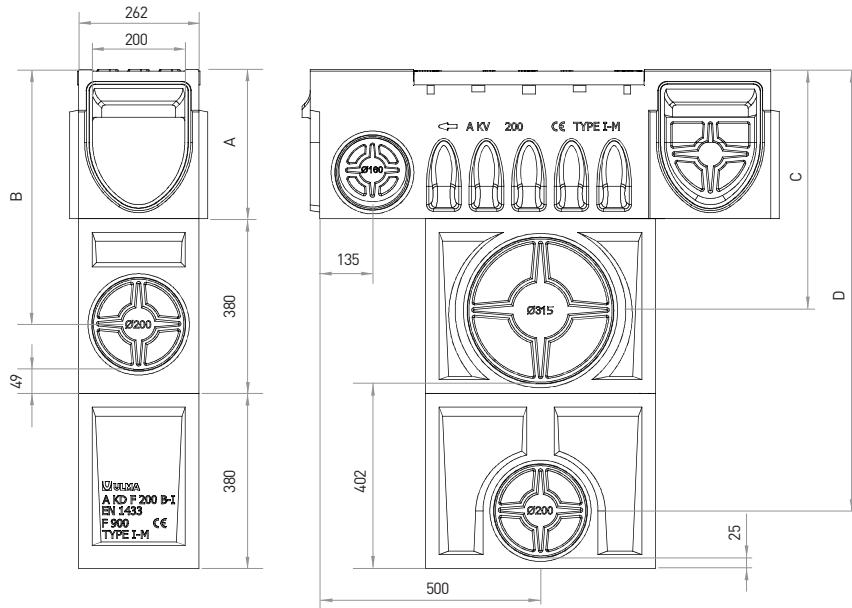

	SUMP UNITS SUPERIOR	A	B	C	D	E	F	G	H	I	J
CITY	AKVFDH200MF10RS	305	532	502	937	912	199	557	882	135	160
	AKVFDH200MF30RS	505	732	702	1137	1112	301	757	1082	203	315
	AKVFDH200MF50RS	705	932	902	1337	1312	473	957	1282	253	400
TRAFFIC	AKVFD200MF10RS	305	532	502	937	912	199	557	882	135	160
	AKVFD200MF30RS	505	732	702	1137	1112	301	757	1082	203	315
	AKVFD200MF50RS	705	932	902	1337	1312	473	957	1282	253	400
INDUSTRY	AKVE200MF10RS	300	527	497	932	907	194	552	877	135	160
	AKVE200MF30RS	500	727	697	1132	1107	296	752	1077	203	315
	AKVE200MF50RS	700	927	897	1332	1307	468	952	1277	253	400
CIVIL	AKVF200MF10RS	325	552	522	957	932	219	577	902	135	160
	AKVF200MF30RS	525	752	722	1157	1132	321	777	1102	203	315
	AKVF200MF50RS	725	952	922	1357	1332	493	988	1302	253	400

GENERAL TERMS AND CONDITIONS OF PROVISION ON WORK SITE

The **ULMA Architectural Solutions** drainage system has been designed and tested under the strictest premises of STANDARD EN1433, following the constructive details illustrated in the following pages. The design of the slab adjacent to the channel/concrete base (concrete, asphalt or paver) assembly must have the necessary shrinkage and expansion joints to avoid any tangential or perpendicular stress on the channel and concrete

base assembly. Depending on the constructive details of the slab, the sizing of these joints will be the responsibility of the Construction Management or planner.

The following illustrations show the appropriate installed section for each type of pavement and load class, as well as the recommended constructive details. However, for sections that are not covered, please consult our technical department.

INDICATIONS COMMON TO ALL THE DIFFERENT TYPES OF INSTALLATION

The trench must have the necessary depth and width to allow the recommended dimensions of the base given in Table 1 to be met according to the type of load required.

If a compaction process is required close to the channel (e.g. asphalt pavement, classes A15 and B125), special care should be taken not to damage the channel edge and walls.

The surrounding pavement and concrete base should be on a level between 3 and 5 mm above the level of the upper edge of the channel.

It is recommended that the land adjacent to the channel should have a degree of compaction of the 95% of maximum dry density.

CONCRETE AND ASPHALTE PAVEMENT

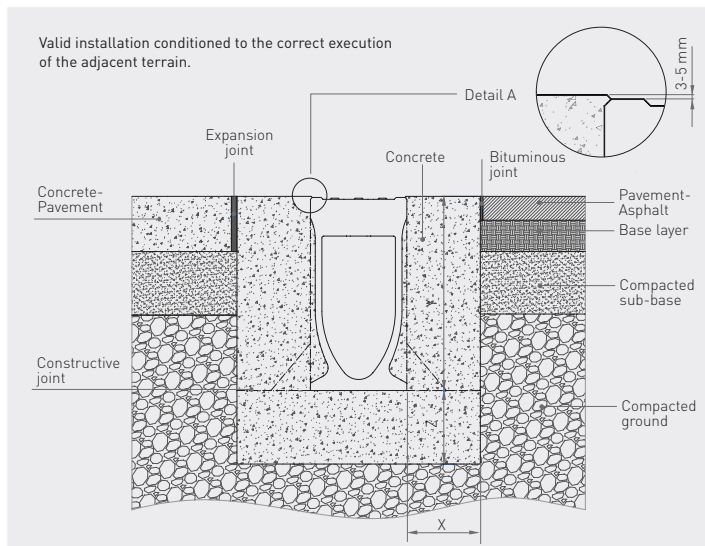

PAVING

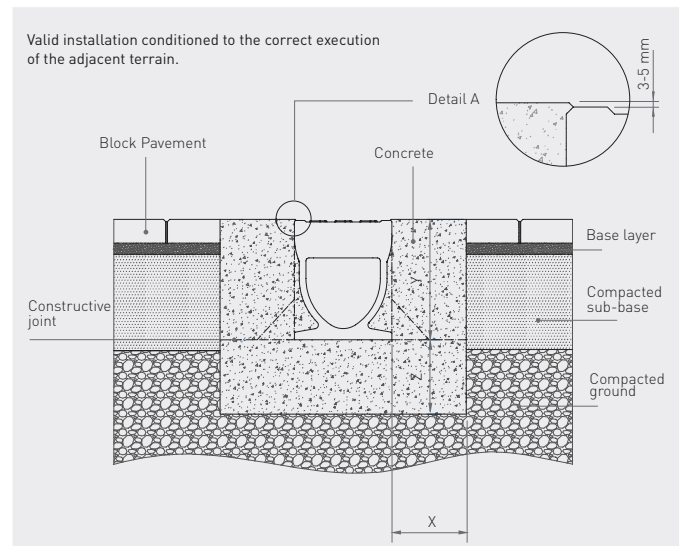

Load class EN 1433 Standard	A15	B125	C250	D400	E600	F900
Concrete type (kg/cm ²) BS EN 1992-1-1 Standard				250	250	250
Minimum distances (mm)	X			150	150 / 200	200
	Y			Channel height + grating+ 3-5mm, see Detail A		
	Z			150	150 / 200	200

Load class EN 1433 Standard	A15	B125	C250	D400
Concrete type (kg/cm ²) BS EN 1992-1-1 Standard	150	250	250	250
Minimum distances (mm)	X	100	100	150
	Y	Minimally up to a point located 40 mm below the floor level		Channel height + grating+ 3-5mm, see Detail A
	Z	100	100	150

* Minimum conditions required for installation. For more details see installation instructions. It is the responsibility of the client to ensure that the installation instructions are compatible with the nature of the terrain.

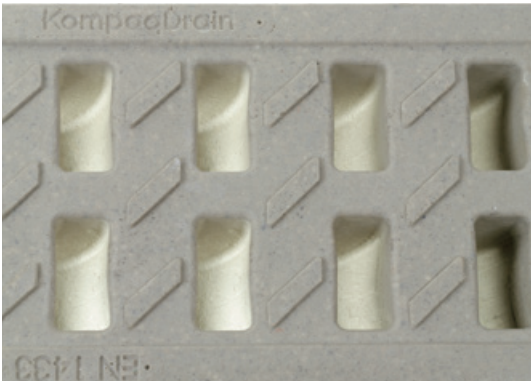

ulmaarchitectural.com

ULMA ARCHITECTURAL SOLUTIONS

Bº Zubillaga, 89 - Apdo. 20
20560 Oñati (Gipuzkoa) Spain
Tel.: 00 34 943 78 06 00
info@ulmaarchitectural.com

KOMPAADRRAIN

962611008 June 2019