



Roofing Sitework Guide

V1.1 - 16.10.2024



CONTENTS

4	ABOUT THIS GUIDE	81	CONCRETE AND CLAY PLAIN TILES	131	DRY FIX AND VENTILATION SYSTEMS
5	GENERAL ADVICE	82	Setting out the roof		EAVES SYSTEMS
6	Storage and handling	85	Eaves	132	Universal eaves vents (10 and 25mm)
7	Safety and access	86	Verges	136	Fascia height settings
10	Roof structure	87	Hips	137	Universal eaves vent clip
11	Loading out	89	Valleys		
12	Underlays	91	Vertical tiling		VERGE SYSTEMS
20	Battens			138	Universal dry verge
23	Cutting tiles	97	CONCRETE AND CLAY INTERLOCKING TILES	144	Universal dry verge refurbishment kit
24	Flashings and weatherings	98	Setting out the roof	145	Edgemere dry verge
32	Fire stopping	103	Eaves	150	Ashmore Dry Verge
33	Rigid boarding/sarking and counter battens	105	Verges	156	Continuous dry verge
35	Fixing materials	107	Valleys	159	Continuous dry verge for slates
38	Mortar bedded ridges and hips	109	Ashmore interlocking tiles	161	Interlocking tile cloak verge
45	Repair and replacement	113	Lincoln clay profiled tiles	166	Clay plain tile cloak verge
				168	Concrete plain tile cloak verge
48	SOLARTILE®	122	SHINGLES & SHAKES		HIP SYSTEMS
49	Orientations	123	Setting out	170	Universal HipFast
55	Electrical	124	General laying	176	Dry hip
56	Fixing guidance	126	Eaves		
57	Installation overview	127	Ridges		VALLEY SYSTEMS
58	Tile battens	128	Hips and valleys	182	Universal dry valley
59	Installation sequence	129	Vertical applications	186	Bonding tiles and secret cut tile clips
		130	Coverage	187	GRP dry valley for slates

DRY FIX AND VENTILATION SYSTEMS (CONTINUED)

RIDGE SYSTEMS

- 189 Universal RidgeFast
- 197 Universal Ridge Roll for slates
- 199 Ventilated dry ridge and dry mono ridge system
- 206 Ridge vent terminals

ABUTMENT SYSTEMS

- 209 Top abutment ventilation
- 213 Individual dry soakers
- 217 Flexfast lead replacement roll
- 221 Roof defence

ROOF SLOPE SYSTEMS

- 228 Universal tile vent terminal
- 231 Tile vent terminals
- 236 Contour tile vent terminals
- 239 Clay in-line vent terminal
- 241 In-line vent slate ventilator

- 244 Bonding gutters

248 TABLES AND TERMINOLOGY

- 249 Eaves fascia heights
- 250 Ventilation roof tiles and vent terminal spacing
- 251 Open valleys – finished channel widths
- 252 Pitched roofing terminology
- 257 Resources



NEED INSTANT SITE ADVICE?

Make roofing on site even easier by using our app to get instant advice, illustrations and step-by-step fixing procedures on your tablet or mobile. Download for free from the App Store or from Google Play.



ABOUT THIS GUIDE

Good pitched roofing practice is the result of many years experience in the practical application of products on all types of roof designs.

This 'Sitework Guide' is based on Marley's long history in the manufacture and specification of clay and concrete tiles, dry fix and roof ventilation systems, and incorporates the recommendations of BS 5250, BS 5534, BS 8612 and BS 8000-6 and in the application of these products.

The Guide contains advice on good sitework practice for traditional installation details as well as the installation of Marley's extensive range of dry fix and ventilation systems.

Full details of these products, including performance and properties, design guidance, special applications and fixing requirements, can be found online, in the

relevant product literature, design guides and technical bulletins or by contacting the Technical Advisory Service.

Notes: This Sitework Guide should be read in conjunction with all relevant Building Regulations, British Standards, Codes of practice and Health & Safety legislation as well as Marley's current product data and Third Party Certificate conditions of use (where applicable).

- 1 BS 5250 – 'Code of practice for the Management of Moisture in buildings'
- 2 BS 5534 – 'Code of practice for slating and tiling'
- 3 BS 8000-6 – 'Workmanship on building sites – Part 6. Code of practice for slating and tiling of roofs and claddings'
- 4 BS 8612 – 'Dry-fixed Ridge, Hip and Verge Systems for Slating and Tiling - Specification'



For advice

Tel: 01283 722588
Email: roofing@marley.co.uk
web: marley.co.uk



GENERAL ADVICE

- 6 Storage and handling
- 7 Safety and access
- 10 Roof structure
- 11 Loading out
- 12 Underlays
- 20 Battens
- 23 Cutting tiles
- 24 Flashings and weatherings
- 32 Fire stopping
- 33 Rigid boarding/sarking and counter battens
- 35 Fixing materials
- 38 Mortar bedded ridges and hips
- 45 Repair and replacement



Dry fix and ventilation systems
For more details, see pages 131-244

STORAGE AND HANDLING

Provision should be made for proper storage and handling of materials to avoid deterioration in quality and appearance, to avoid breakage or distortion, and to minimise wastage.

GENERAL

- 1 Tiles should be stored in a safe location and should be kept protected from damage on site. Pallets should be stored on a smooth, level base capable of supporting their weight.
- 2 Store roof underlays on end, on a firm, clean base protected from direct sunlight and in accordance with manufacturers' instructions
- 3 Store battens and counter battens on sufficient bearers to prevent sagging or twisting.
- 4 Protect battens and counter battens from water saturation when stored in bales or bundles horizontally.
- 5 Store roof accessories in a safe, weatherproof store/location.

Pallets and crates should be transported using appropriate lifting machinery, i.e. fork lift or mechanical grab. Unload and handle tiles and fittings with care to avoid damage, soiling and breakage. Avoid loading pallets onto scaffolding unless a safe access platform has been provided.

Most Marley products are provided palletised, banded and shrink wrapped, and can be delivered direct to site by a fleet of modern transport with mechanical off-loading facilities.

The products are delivered as follows:

- Clay plain tiles – packed on pallets or in crates and shrink wrapped
- Concrete plain tiles – palletised, banded and shrink wrapped
- Concrete interlocking tiles and slates – palletised, banded and shrink wrapped
- Clay interlocking tiles – palletised and banded on pallets.

STORAGE OF CLAY AND CONCRETE TILES

Tiles should be stored in a safe location and should be kept protected from damage on site. Pallets should be stored on a smooth, level base capable of supporting their weight. Do not stack tiles more than 3 pallets high in stockyards or 2 pallets high on site.

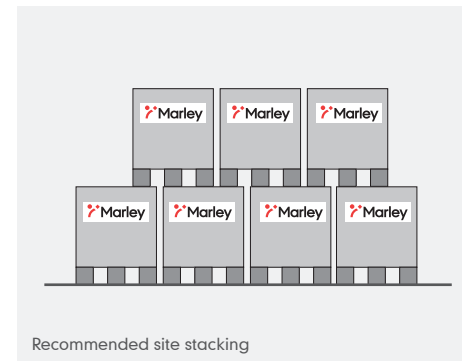

SAFETY AND ACCESS

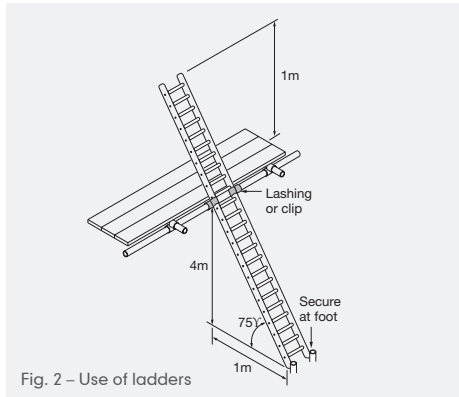
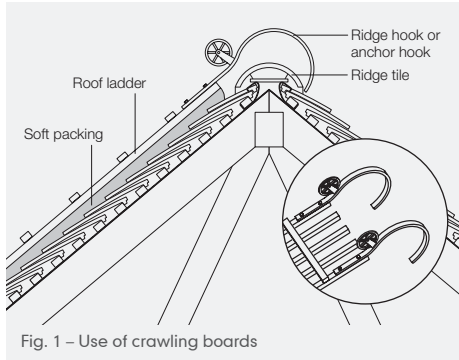

SAFETY REGULATIONS

The Construction Regulations made under the Factories Act 1961 comprise:

- The Health and Safety at Work Act 1974
- The Construction (Design and Management) (Amendment) Regulations 2015
- The Management of Health and Safety at Work Regulations 1999
- Work at Height Regulations 2005
- Control of lead at work – Control of Lead at Work Regulations 2002

See page 23 for information on RPE and PPE requirements.

HEALTH AND SAFETY EXECUTIVE

Advice and guidance on site health and safety can be found at the HSE website: www.hse.gov.uk

ACCESS

Any roof or vertical work in slating or tiling should be treated as fragile. An adequate

number of crawling boards and ladders should be used for gaining access over completed areas of roof tiling, and should be designed for the purpose, be of good construction and strong enough to enable planned work to be carried out. The boards or ladders should also be properly supported on the sloping part of the roof by means of a ridge hook placed over the ridge (not bearing on the ridge tiles), and supported by soft packing material (Fig. 1).

The Regulations also require precautions to be taken when access ladders are used (see Fig. 2). Full requirements are given in 'HSG33', Health and Safety in roof work 2020.

Ladders used to gain access to working platforms or to the eaves of the roof should be in good sound condition, fully secured with the feet resting on a solid flat surface. The length should extend above the level of the landing by 1m with an angle of slope of 1:4 (1m out for every 4m height).

The requirements to secure ladders should be particularly noted.

SAFETY AND ACCESS

WORK ON ROOFS

On traditional pitched roofs, most injuries occur as a result of one of the following: a fall from the eaves; slipping down the slope of the roof and over the eaves; falling through the roof trusses; falling from the gable end. Unless work is only for a very short duration, full edge protection must be provided on all elevations of the roof where access is needed.

Health and Safety in Roofwork HSG 33, provides a useful guide to safe working and is freely available to download from the HSE website.

STRIP AND RE-ROOF

An independent tied scaffold is required. Guidance to the scaffold specification is given in BS EN 12811-1: 2003.

TG 20:08 produced by the National Access and Scaffolding Confederation gives technical guidance on the use of BS EN 12811-1.

OTHER WORK

Where a person can fall from the lower edge of a sloping roof, a catch barrier should be provided at the edge (scaffolding as shown in Figs. 3 and 4 is ideal).

The platform should comply with BS 5973.

Where sloping roof edge protection takes the form of a working platform below the eaves, the platform should:

- be 300mm below eaves
- project at least three boards beyond the edge of the roof
- be fitted with both an intermediate rail and guard rail
- have a 150mm high toe board (Fig. 3)

The top lift of a scaffold providing sloping edge protection should be dimensioned as follows (Fig 4):

- i) working platform minimum width 600mm
- ii) minimum 950mm
- iii) maximum gap 470mm
- iv) to rise to the line of the roof slope with a minimum height of 150mm
- v) gap between rails no more than 470mm

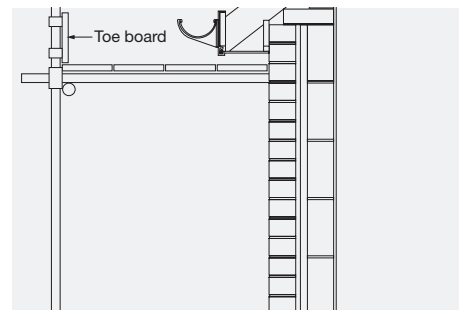

Fig. 3 – Sloping roof edge protection

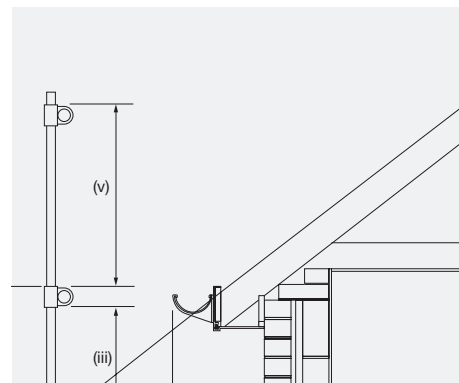

Fig. 4 – Top lift of scaffold providing working platform

SAFETY AND ACCESS

PRECAUTIONS

- 1 Do not rest ladders used for access at eaves level against gutter.
- 2 Position ladder away from wall with a stand-off and make secure when clearing out gutters
- 3 Access ladders should extend to project not less than 1.0m above landing position.
- 4 Take care when working near metal or open valleys so as not to damage side coverings.
- 5 Take great care when fixing eaves gutters, immediately below valleys. Valley troughs are vulnerable to breakage, and should not be eased or levered.
- 6 Provide some form of packing between roof ladders, crawling boards and covering materials (e.g. straw-stuffed sacks, thick sheet, rubber etc.) to prevent damage of tiles. This is important where lightweight tiles or slates are used.
- 7 Materials and tools should not be drawn or dragged over the roof covering.



Safety and general precautions check points

- Ensure that all legal safety requirements are met by reference to the following:

The Health and Safety at Work Act 1974

The Construction (Design and Management) (Amendment) Regulations 2015

The Management of Health and Safety at Work Regulations 1999

Health and Safety in Roofwork HSG33 2020

The Work at Height Regulations 2005

- Ensure all scaffolds and ladders are properly secured and where necessary, scaffold should be checked for safety certificates before using.
- Provide guard rails and toe boards on scaffolds.

- Avoid trafficking over completed tiled and slated roof areas.

- Use a roof ladder for access, maintenance and repair, suitably packed to avoid damage to the roof covering.

- Cured tiles are inert but edges and surfaces can be sharp and abrasive, wear suitable gloves for protection.

- Machine cutting of cured tiles can create dust which may contain quartz. If inhaled, in excessive quantities over long periods, respirable dust containing quartz can constitute a health hazard. Exposure should not exceed published health standards. (For current standards, see 'Construction Dust: Cutting of Roof Tiles' HSE website).

ROOF STRUCTURE

Before commencing work check:

- 1 Roof trusses are to a true line and adequately braced as specified.
- 2 Roof structure is to an acceptable squareness, tolerance and to specified minimum pitch (Fig. 5).
- 3 Flashings and secret gutters, covered by the slating or tiling, are positioned and secured to specification (see eaves fascia height tables, pages 136 and 249).
- 4 Fascia boards and gutters are positioned and secured to specification.
- 5 Gable brickwork has been levelled to be below rafter truss.
- 6 Fascia boards or tilting fillets are positioned to allow eaves course of tiles or slates to be in same plane as main roof, i.e. not drooped or elevated.
- 7 Report any discrepancies to site management before work progresses.

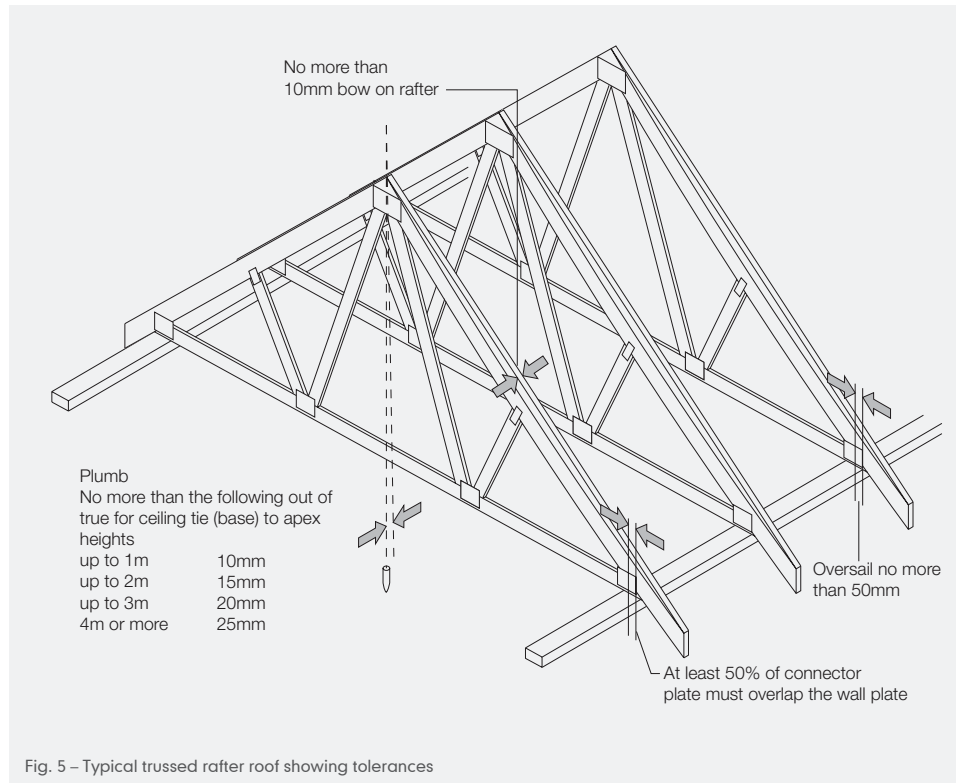

Fig. 5 – Typical trussed rafter roof showing tolerances

LOADING OUT

GENERAL

- 1 Before slating or tiling commences, check delivered products against initial order and report any discrepancies or defective materials to the site agent or manufacturer.
- 2 Pallet loads should be checked for batch codes to ensure consistency on large roof areas. Set-out and strike perpendicular lines on the roof prior to loading out the roof.
- 3 Special fittings should be checked against matching tiles to ensure suitability before tiling commences.

LOADING THE ROOF WITH TILES

- Load slates, tiles and fittings out on roof safely, support by battens to avoid slippage and distribute evenly to prevent overloading of roof structure (Figs. 6-9). Ensure stacks are positioned over rafters.
- All slates and tiles, especially variegated and granular faced tiles, should be mixed from different pallet loads whilst the roof is being loaded to enhance the appearance when laid.

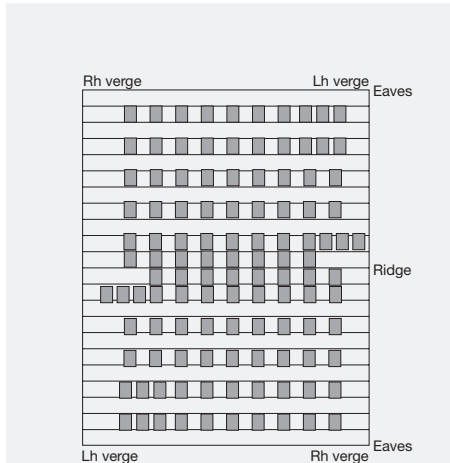

Fig. 6 – Loading roof evenly with tile/slate stacks

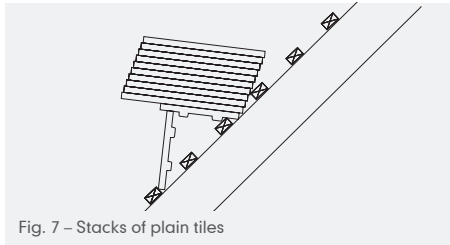

Fig. 7 – Stacks of plain tiles

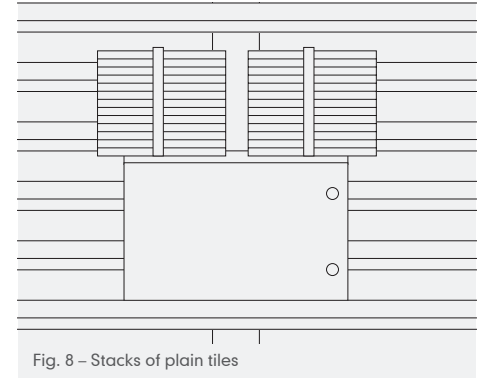

Fig. 8 – Stacks of plain tiles

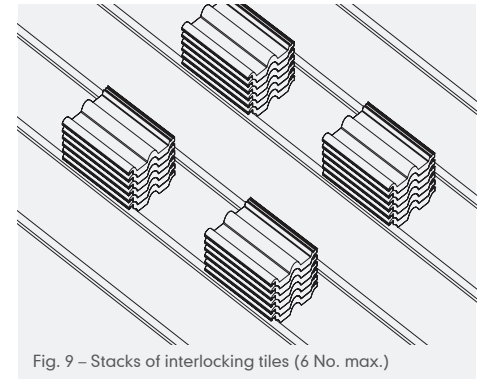

Fig. 9 – Stacks of interlocking tiles (6 No. max.)

UNDERLAYS

GENERAL

Underlays for use beneath tiles and slates are either fully supported over boarding, sheathing or sarking, or unsupported draped over rafters/counter battens and should meet the following:

FULLY SUPPORTED UNDERLAYS

- 1 HR* underlay to BS EN 13859-1 Class W1 water penetration classification with third party certification for the use intended. Marley Universal non-breathable underlay is an ideal solution (BBA cert. 16/5335).
- 2 LR† underlay to BS EN 13859-1 Class W1 water penetration classification with third party certification for the use intended. Marley Universal vapour permeable underlay is an ideal solution (BBA cert. 16/5334).

UNSUPPORTED UNDERLAYS

- 1 BS 8747 Class 1F Reinforced Bitumen or Class 5U polyester reinforced bitumen.
- 2 HR* underlay to BS EN 13859-1 Class W1 water penetration classification with third party certification for the use intended.

- 3 LR† underlay to BS EN 13859-1 Class W1 water penetration classification with third party certification for the use intended. Refer to Marley Universal underlays where applicable (for third party BBA certification, refer to Certificates 16/5335 and 16/5334)

* HR (high water vapour resistance) underlay >0.25MN.s/g

† LR (low water vapour resistance) underlay <0.25MN.s/g
LR underlays are sometimes referred to as 'vapour permeable' or 'vapour open'.

GENERAL LAYING RECOMMENDATIONS

- 1 Lay specified roofing underlay parallel to eaves or ridge with horizontal overlaps as specified in the table overleaf. Vertical side laps should be 100mm.
- 2 The underlay should be draped between rafters or supports to allow water to discharge away from the batten nail holes and drain into the gutters at the eaves (maximum drape 15mm).
- 4 Fix underlay with clout nails, keeping number of perforations to a minimum.

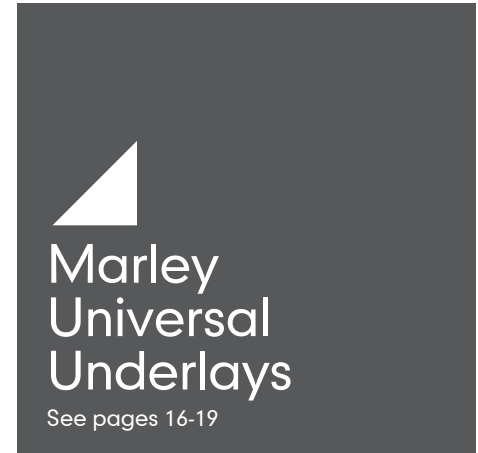

- 5 Handle and fix underlay with care to ensure no tears or punctures. Repair any tears or punctures prior to tiling.
- 6 Ensure that underlay does not obstruct flow of air through ventilators located at eaves, ridge or in main roof.

UNDERLAYS

- 7 Weather appropriately all holes formed in underlays for soil vent pipes etc.
- 8 Underlay laps should be covered by a batten and where necessary, the lap of the underlay adjusted to coincide with the nearest slating or tiling batten. Laps may also be sealed using proprietary means in accordance with manufacturers' instructions. Where a proprietary sealant is used, its durability should meet the same recommendations as the underlay. Refer to geographical wind zones for wind pressure resistance figures.
- 9 Contact should be avoided between the underlay and the underside of the slates or tile to prevent the wind uplift load being transmitted to the slates or tiles.

MINIMUM HORIZONTAL LAP FOR UNDERLAYS

Rafter pitch	Not fully supported	Fully supported	Vertical laps
12.5 - <15°	225mm	150mm	100mm
≥15°	150mm	100mm	100mm

BS 5250 and BS 5534 give advice on the installation of underlays and roof ventilation requirements.

EAVES

- 1 Lay the underlay over a suitable support tray stopped approx. 25mm from the top of the curved front edge.
- 2 Underlay at the eaves should be set back from exposure and lapped onto a UV stable support tray or 5U felt.
- 3 Avoid water-traps behind the fascia board (Fig. 10).

DUO RIDGE

- 1 Carry the underlay over the apex and fix to the required minimum headlap (see table, left).

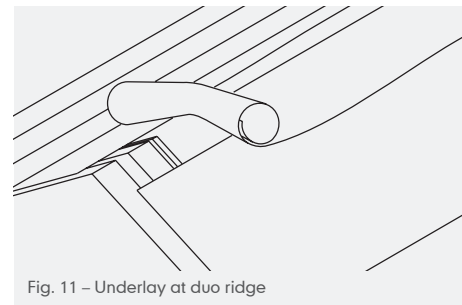
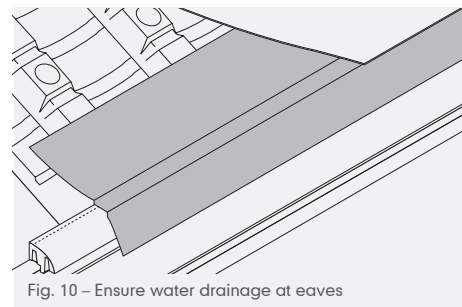

UNDERLAYS

MONO RIDGE

- 1 Lay or cut top course of underlay (not less than 100mm) over top of fascia board and fix to same.

HIPS

- 1 Continue underlay over hip and fix in an overlapping manner.
- 2 Ensure that a minimum lap of 150mm is maintained (Fig. 12).

Note: An additional strip minimum 500mm wide may be laid over the main roof underlay taking care to avoid excessive thickness.

VALLEYS

- 1 Lay underlay parallel to eaves and extend beyond centre line of valley by not less than 300mm from each direction to give a double thickness of underlay in valley of not less than 600mm wide.
- 2 Fix underlay not less than 100mm from centre line of valley.
- 3 Where underlay is cut to centre line of valley, lay a continuous strip of underlay not less than 600mm wide for the full length of valley beneath main courses of underlay (Fig. 13).
- 4 Where layboards are provided for continuously supported metal and GRP valleys, underlay should be cut back to rake so as to lap over metal valley tilting fillets.
- 5 Do not lay metal and GRP plastic valley materials and units directly onto underlay where there is any risk of adhesion.

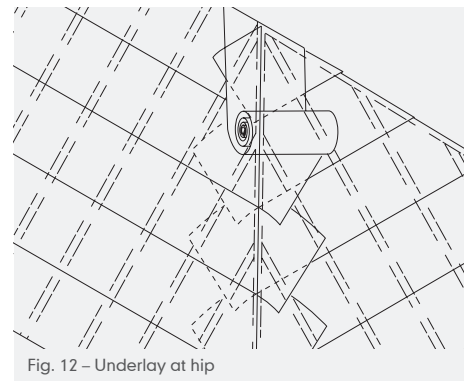

Fig. 12 – Underlay at hip

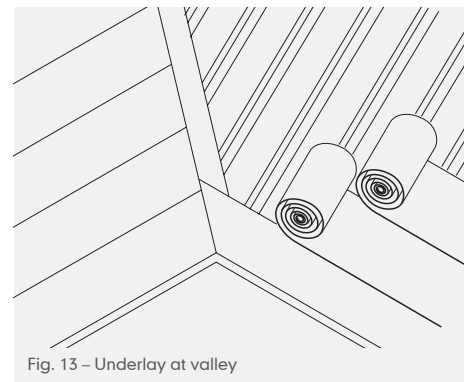

Fig. 13 – Underlay at valley

UNDERLAYS

VERGES

- 1 Underlay intended for use on bedded verges should be carried across the wall cavity by no less than 25-50mm. For dry verge units, apply the underlay in line with the specific guidance for the product.

SIDE/FRONT ABUTMENTS

- 1 Turn the underlay up so that the top edges are covered by the flashings by no less than 50mm.

BACK ABUTMENT

- 1 Dress or cut underlay neatly to provide not less than 100mm for roofs pitches of 35° and over, and not less than 150mm for roof pitches between 15 and 30°

UNDERLAY PENETRATIONS (SOIL PIPES)

- 1 Accurately locate and mark position for opening using pipe etc. as a template.
- 2 Neatly cut an 'X' shaped hole and turn up flaps around sides of pipe to minimise risk of any water leakage.

VERTICAL LAPS

- 1 Vertical laps should be not less than 100mm. Fix each end securely over rafters. Edge distance of fixings should be at least 50mm.

HORIZONTAL LAPS

- 1 Horizontal lap should be not less than that given in table on page 13.
- 2 For underlays not fully supported, horizontal laps should be secured in accordance with BS 5534, by either increasing the lap to coincide with a naturally occurring batten course, or alternatively, through the use of a tape system for sealing underlay laps.

Note: The use of an additional fly batten is permissible under the British Standard, however it is not recommended because it can – in some circumstances – create a tripping hazard.

Marley Universal underlays come with an integrated tape system for sealing laps.

UNIVERSAL UNDERLAYS

Universal vapour permeable and non-breathable underlays from Marley are a high quality selection of high performance and lightweight membranes, designed to integrate either as part of a complete Marley roof system, or used in conjunction with other manufacturers' tiles and slates.

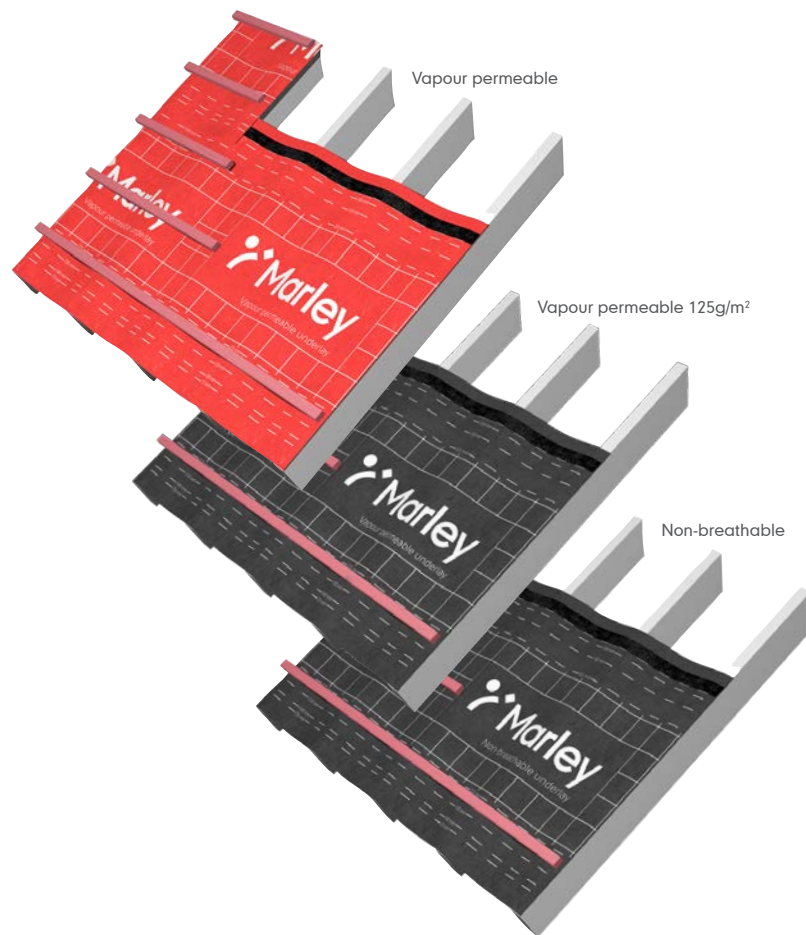

UNIVERSAL UNDERLAYS

INSTALLATION

Each underlay is manufactured using the latest materials and processes, and each incorporates a number of useful features which assist in ensuring installation that is not only correct, but also compliant with the latest British Standards.

BBA approved:

- Certificate No.19/5678 for vapour permeable
- Certificate No.19/5673 for non-breathable



Marley underlay should be laid horizontally across the rafters, starting at the eaves. It should not be stretched taut over the rafters, but draped as shown, in order to allow for small temperature movements and to ensure a gap between the tile batten and underlay for drainage down to the gutter.

Marley vapour permeable underlay must always be fixed with the PRINTED side facing outwards. Seal laps with integral tape.

MINIMUM LAP

Roof pitch	Horizontal laps		Vertical laps
	Not fully supported	Fully supported	
12.5° to <15°	225mm	150mm	100mm
≥15°	150mm	100mm	100mm

BS 5250, BS 5534 and BS 8000-6 give advice on the installation of underlays and roof ventilation requirements.

ZONAL COMPLIANCE

Summary of test results for wind uplift resistance of Universal non-breathable underlay to BS 5534 Annex A.

Geographical wind zones	250mm batten gauge taped lap using integral tape	345mm batten gauge taped lap using integral tape
	Zones 1-5	Zones 1-5

TYPICAL DETAILS

The illustrations shown here are examples of typical constructions. Many other types of construction for eaves, hip, valley, ridge and abutment are possible and may require different underlay configurations.

EAVES

A 500mm strip of UV resistant underlay should be supported on a continuous tilting fillet or proprietary underlay support tray and dressed down into the gutter (Fig. 14).

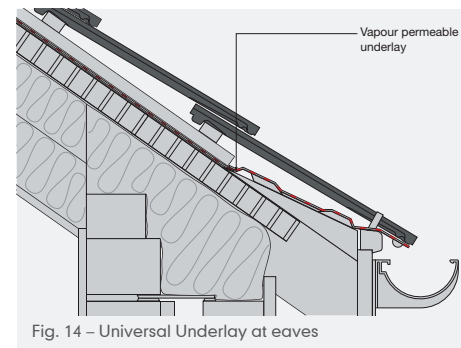

Fig. 14 – Universal Underlay at eaves

UNIVERSAL UNDERLAYS

RIDGES

For ventilated ridges, Marley vapour permeable underlay should be cut short or set down from the ridge to leave a continuous gap of not less than 5mm (Fig. 15).

HIPS

Underlay at the hips should be lapped over both sides of the hip rafter by no less than 150mm (Fig. 16).

VALLEYS

For tiles, lead or proprietary valley systems, a valley underlay strip of Marley vapour permeable underlay at least 600mm wide should be laid under the main roof underlay (Fig. 17).

ABUTMENTS

Marley vapour permeable underlay should be turned at the abutment so that the top edge is covered by the flashings by no less than 50mm to prevent rain and snow being blown into the roof space. For ventilated top abutments, the underlay should be cut or set down from the top edge by no less than 5mm (Fig 18).

Marley offer a comprehensive range of dry fix BS 5534 options for all the above constructions. These can be found on pages 209-221.

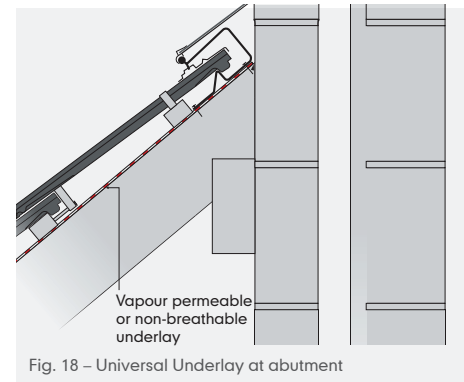
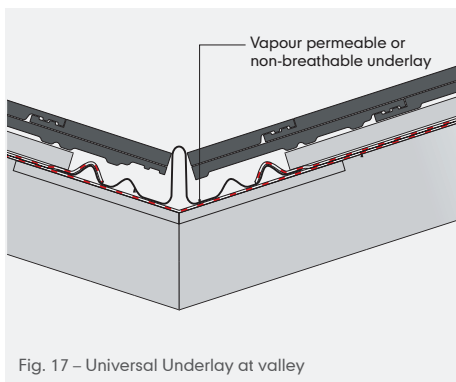
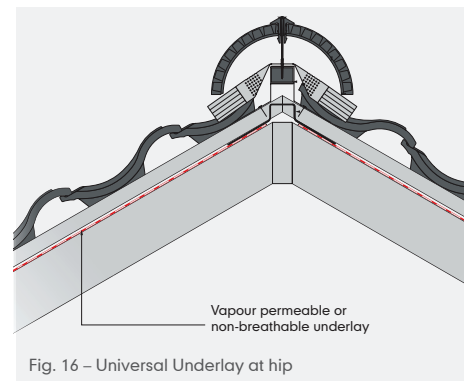
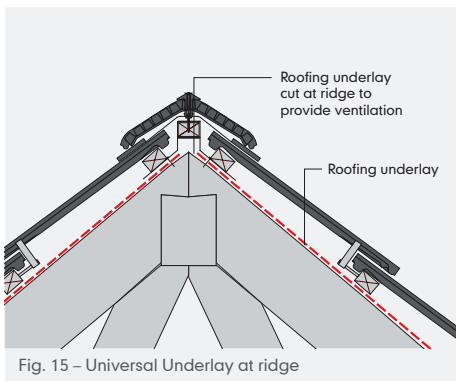

UNIVERSAL UNDERLAY – VERTICAL USE

Marley Vapour Permeable Underlay (code MA33150) for use in timber frame construction is satisfactory for use as on-site or factory-applied breather membrane in timber-frame walls with a cavity and a masonry outer leaf, weatherboarding or tile/slate cladding.

- 1 Marley Vapour Permeable Underlay for use in timber frame constructions must be installed in accordance with the recommendations given in NHBC Standards, Chapter 6.2 External timber framed walls, where appropriate.
- 2 The underlay must be secured at regular intervals not exceeding 500mm with clout nails to prevent damage by wind action.
- 3 Upper layers should overlap lower layers to shed water away from the sheathing. Vertical laps should be staggered wherever possible.
- 4 Horizontal and vertical laps should not be more than 100mm laps.



- 5 It is essential that the positions of the timber studs (where installed) are marked, preferably with tape, to enable the fixing of battens or counter battens.
- 6 It is essential that the lowest timbers in the wall are protected by the breather membranes.

BATTENS

RECOMMENDED BATTEN SIZES (BS 5534)

Tile or slate type	Basic minimum sizes			
	up to 450mm span		451 - 600mm span	
Rafters/support	width	depth	width	depth
Plain pitched/vertical	38mm	25mm	38mm	25mm
Single lap interlocking tiles/slates	38mm	25mm	50mm	25mm
Double lap slates – Natural (sized/random)	50mm	25mm	50mm	25mm
Double lap slates – fibre cement/concrete	38mm	25mm	50mm	25mm

All dimensions subject to re-sawing allowance: width + 3mm depth 0 or + 3mm based on measurement at a reference moisture content of 20%.

- One of the biggest issues with roofing battens is under sizing. To avoid this, there is now a clear tolerance limit for the minimum depth of a roofing batten, which is +3mm/-0mm. Also, roofing battens cannot be less than 25mm deep and where the span between supports exceeds 600mm, calculations must be completed to determine their correct dimensions for structural integrity.

CHOOSING BATTENS

- Roofing battens must meet the recommendations stated in BS 5534 in terms of their species, permissible

characteristics and defects (knots, fissures and splits, wane, slope of grain, rate of growth, distortion, decay and insect attack, sap stain, resin pockets and moisture content), including minimum dimensions and grading requirements.

- To help meet these minimum standards, roofing battens delivered to site should be graded with the following information in accordance with the standard:
 - Name of supplier (the company that graded the roofing battens NOT the company that cut them)

- Origin
- Graded in accordance with BS 5534
- Basic size
- Type of preservative (if applicable)

- All roofing battens must conform to the requirements set out in BS 5534 and must be checked prior to installation. Failure to do so risks increasing unnecessary waste, invalidating warranties and introducing a health and safety hazard on site.

JB Red battens, available from Marley, not only fully comply with BS 5534: 2014 + A2: 2018, but are also recognised by third party certification of conformity. Each batten is laser scanned and graded prior to delivery, providing all the assurances required to comply with the British Standard – ensuring the highest quality of batten available with the least waste and lowest risk to health and safety.

CHOOSING COUNTER BATTENS

- It is important to note that counter battens need not be marked or graded where they are fully supported by the rafters.

BATTENS

In cases where they are used to restrain insulation boards and are subject to upward bending loads they should be graded in accordance with BS 5534.

- 2 If counter battens are used to provide a ventilation gap beneath the roof covering, there is a potential risk of high levels of moisture, and it may be advisable for them (and the roofing battens fixed above) to be preservative treated in order to provide the required durability.

FIXING BATTENS

- 1 Minimum batten length: where there are at least three supports, batten lengths should span over those three supports.
- 2 Splay nail each batten end and nail battens to each rafter.
- 3 On trussed rafter roofs for interlocking tiles, allow not more than one joint in any four consecutive battens on same support.
- 4 On trussed rafter roofs for Plain tiles, allow not more than three joints together in any twelve consecutive battens on same support.

- 5 Batten sizes given in table on page 20 should be taken as minimum dimensional requirements.
- 6 Take care that nails used to secure tiles do not penetrate underside of battens or underlay.

BATTEN END CLIPS

For use with battens when installing dry verge systems, the Marley batten end clip ensures quick easy and positive fixing of verge units to batten ends. See pages 138-168 for further application information.

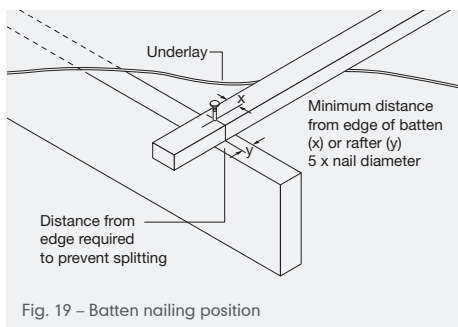

Fig. 19 – Batten nailing position

ROOF BATTENS

- 1 Fix specified battens up roof slope on top of rafters ensuring minimum 40mm nail penetration into rafters (smooth shank).
- 2 Nail counter battens at maximum 300mm centres vertically up roof slope where boarding is used to coincide with line of rafters.

WALL

- 1 Fix specified battens to boarding/ sheathing/sarking in line with vertical supports, or to masonry wall as specified.
- 2 Secure counter battens to masonry walls with specified fixings.



More about
JB-Red Battens

See page 22

JB RED ROOFING BATTENS

JB Red battens, available from Marley, and part of our complete 'roof system' are a sure way of ensuring compliance. They not only fully comply with BS 5534, but are also recognised by third party conformity certification.

Each batten is laser scanned and graded prior to delivery, providing all the assurances required to comply with the British Standard – ensuring the highest quality of batten available with the least waste and lowest risk to health and safety.

The RED colour means that JB Red battens are highly visible on site, therefore Local Authority Building Control, NHBC and other inspectors can see that high quality, pre-graded and compliant product has been used.

JB Red roofing battens have full chain of custody (FSC or PEFC) certification.

JB Red have the following benefits:

- Pre-graded to all the size and strength requirements of BS 5534 for roofing battens
- Marked according to BS 5534 showing supplier name, origin/species, grade and size
- The product and process is UKAS third party assessed by the BBA with a BBA Agrément certificate
- JB Red is LABC registered and is approved for use by local authorities
- Manufactured from slow grown, high grade timber
- Only kiln dried sideboard timber is used to ensure stability and dimensional accuracy
- Treated to BS 8417 Usage Class 2, using Koppers MicroPro™ with a unique red colour
- Has a 60 year lifetime expectancy against insect attack and wood rotting fungi (when installed correctly in accordance with the requirements of Usage Class 2).
- Reduced wastage through state of the art mechanical grading

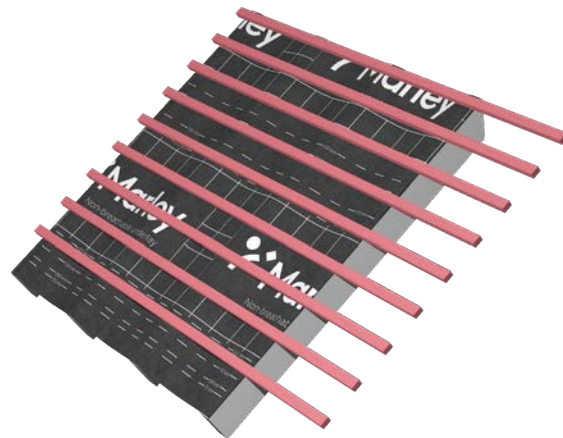

CUTTING TILES

All cutting of tiles should be carried out in well ventilated areas to prevent the inhalation of dust, in accordance with Health and Safety recommendations (Refer to NFRC Health and Safety Guidance Note HSGS 06 – Controlling Silica when disc cutting roof tiles).

- 1 Wherever possible, avoid dust inhalation by using cutting equipment fitted with dust extraction or dust suppression.
- 2 Always wear appropriate personal protective equipment (goggles/protective clothing/ear defenders/and approved respirator) when mechanically cutting tiles.



Fig. 20 – Use a disc cutter for mitring or cutting tiles to rake

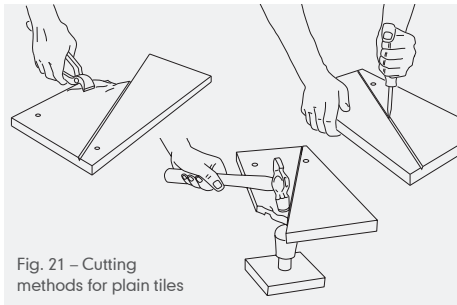

Fig. 21 – Cutting methods for plain tiles

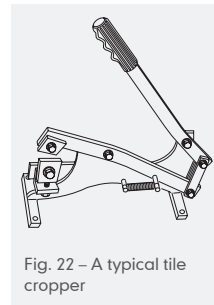

Fig. 22 – A typical tile cropper

See HSE guidance on Respiratory Protective Equipment (RPE) at hse.gov.uk

- 3 After cutting or drilling tiles, wash off all dust from the surface to avoid staining.
Product Data Sheets which comply with the Control of Substances Hazardous to Health (COSHH) regulations are available for all Marley roofing products.
- 4 Avoid cutting tiles that are laid in situ, particularly open valleys, as this may cause damage to the valley lining, and is also a health and safety hazard.

CLAY AND CONCRETE INTERLOCKING TILES

- 1 Where covered by hips or flashings, it may be possible to reduce the risks associated with disc cutting, by cutting the tiles using hand tools (e.g., scribes, pincers, hammers)
- 2 Tiles cut to rake or mitre in open details, e.g. valleys, external angles, should be trimmed with a disc cutter (Fig. 20) to ensure a neat finish.

CLAY AND CONCRETE PLAIN TILES

- 1 Traditionally, Plain tiles can be cut using hand tools (e.g., scribes, pincers, hammers, tile croppers) for most details. However, to ensure a neater finish, it is advisable to use a disc cutter where the cut edges are more visible.

FLASHINGS AND WEATHERINGS

INTRODUCTION

Whilst lead sheet is the most common material for flashings and weatherings for tiled and slated roofs, pre-formed flashings and other lead replacement products are growing in popularity. These represent a much lower material cost and can be installed without the need for specialist tradesmen.

Marley offers a range of pre-formed plastic soakers and GRP dry valleys, and our Flexfast lead replacement roll, that can greatly reduce the requirement for specialist lead and expensive lead material.

Lead is malleable and can be easily dressed to fit the multi-curved contours of profiled interlocking tiles or flat slates and tiles.

BS EN 12588* gives the specification for lead for use in roof flashings and weatherings as summarised in the table.

* BS EN 12588 – ‘Lead and lead alloys. Rolled lead sheet for building purposes’.

The following rules apply when using lead as a flashing and weathering:

- 1 Single pieces should be limited in size (the thinner the piece, the smaller the size) so that natural expansion and contraction is kept to a minimum and the risk of severe distortion (with associated risks of fatigue cracking) is avoided.
- 2 Fixings (while not restricting thermal movement) must be adequate to support the lead and (dependent on exposure) retain it in position.
- 3 Joints must allow for thermal movement, yet remain weathertight for the location in which they are used.



LEAD SHEET FOR BUILDING PURPOSES TO BS EN 12588

Code No.	Colour code	Thickness (mm)	Weight (kg/m ²)	Max. length (m)	Uses
3	Green	1.32	14.97	1.0	Soakers
4	Blue	1.80	20.41	1.5	Flashings / inclined valley gutters / saddles
5	Red	2.24	25.40	1.5	Horizontal valley gutters

FLASHINGS AND WEATHERINGS

Laps between lead flashings should be adjusted to suit the pitch of the roof (see Fig 23). At valleys, note that the pitch will normally be around 5 degrees lower than the roof pitch.

- 4 All lead flashings and soakers should be treated on both sides with patination oil to prevent water run-off and moisture-containing lead oxide from staining the roof covering.

Flashings and weatherings may also be formed from copper, aluminium or zinc as prescribed in BS 5534.

Proprietary materials formed using GRP, PVC or colour coated aluminium with a bituminous adhesive backing should be fixed in accordance with the manufacturers recommendations.

INTERLOCKING AND PLAIN TILE DETAILS

At all abutments where the tiling meets walls or chimneys use an adequate flashing material to weather the junction.

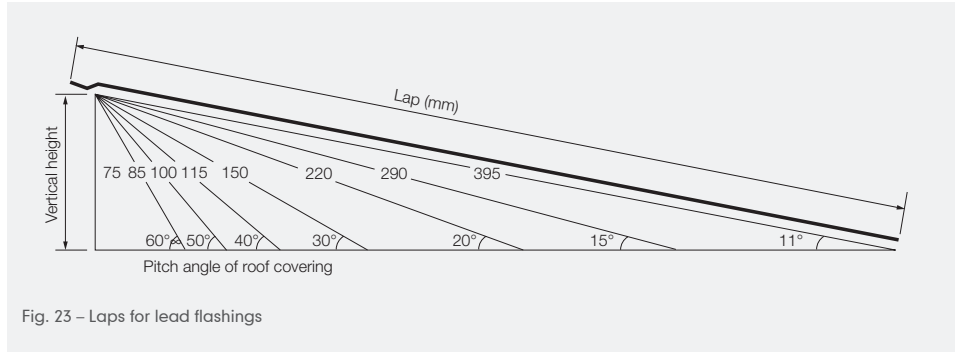

Fig. 23 – Laps for lead flashings

TOP EDGE ABUTMENT

- 1 Turn roofing underlay up at abutments so that the top edge is covered by the flashing by no less than 50mm.
- 2 Fix top tiling batten as close as possible to abutment.
- 3 Complete tiling in the usual way.
- 4 Chase out abutment wall and insert lengths of Code 4 lead, not more than 1.5m long and wedge in with small pieces of lead not less than 450mm apart.
- 5 Lead should be wide enough to give at least 150mm cover to top course of tiles (e.g. below 30° this increases to 200mm at 15° rafter pitch).
- 6 Vertical upstand should be 75-100mm.
- 7 Lap each length of lead by not less than 100mm.
- 8 Dress lead to profile of tiles (Fig. 24).
- 9 Secure lead flashings with copper or stainless steel clips with frequency dependent on exposure (see Lead Sheet Association recommendations).

FLASHINGS AND WEATHERINGS

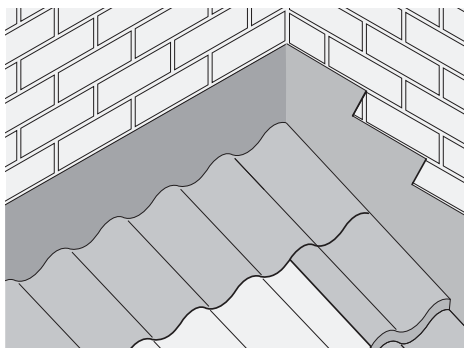

Fig. 24 – Top edge abutment

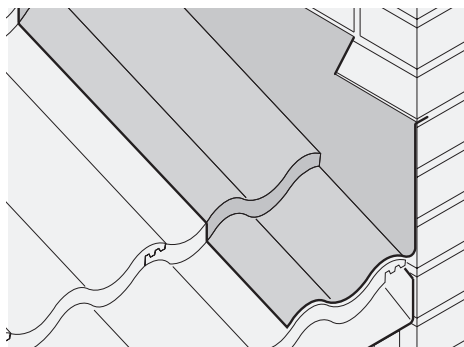

Fig. 25 – Stepped flashing with profiled interlocking tiles

SIDE ABUTMENTS

There are four common ways of weathering a side abutment with interlocking tiles:

- 1 Stepped cover flashings.
- 2 Secret gutters.
- 3 Combination of stepped cover flashing above secret gutter.
- 4 Marley dry fix soakers

STEPPED COVER FLASHING

- 1 Turn roofing underlay up at abutments so that the top edge is covered by the flashing by no less than 50mm.
- 2 Finish tiling battens 10-25mm short of the wall and fix securely.
- 3 Lay tiles to butt as close as possible to wall.
- 4 Cut a piece of Code 4 lead to form a combined step and cover flashing.

- 5 Flashing should not exceed 1.5m in length and should be 150-200mm width or wide enough to cover the first roll, whichever gives the greater cover.
- 6 Chase out brickwork mortar joints and push folds of flashing into chases and secure into the joints with lead wedges.
- 7 Dress cover flashing as tightly as possible to tile profile (Fig. 25).
- 8 Repoint brickwork with mortar or suitable flexible sealant
- 9 In areas of high exposure or when dressing lead over flat tiles, use clips to hold cover flashing in place. When using this type of flashing with flat tiles below 25°, increase cover of flashing over tile to 200mm.

FLASHINGS AND WEATHERINGS

ABUTMENT WITH SOAKERS AND STEP FLASHINGS

Soakers are used where double-lap Plain tiles abut a wall.

- 1 Turn roofing underlay up at abutments so that the top edge is covered by the flashing by no less than 50mm. Finish tiling battens 10-25mm short of the wall and fix securely.
- 2 Lay tiles close to abutment with a soaker fitted between each tile, with the bottom soaker set slightly back from the tail of the tile.
- 3 The length of the soaker should be Gauge + head lap of the tile + 25mm to turn over the head of the tile (e.g., 100mm + 65mm + 25mm = 190mm Fig 26).

After all tiles and soakers have been fixed, insert a stepped flashing into abutment wall and dress down over upturned edges of soakers (Fig. 27).

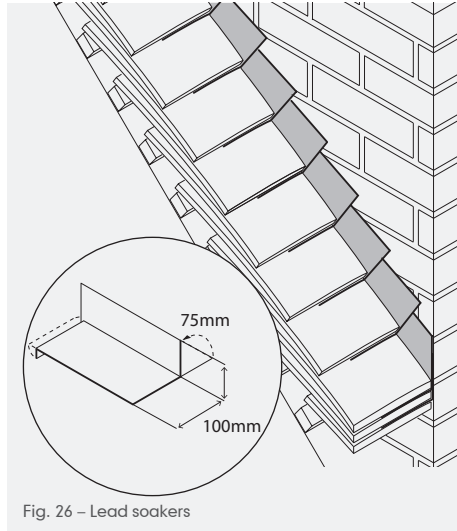

Fig. 26 – Lead soakers

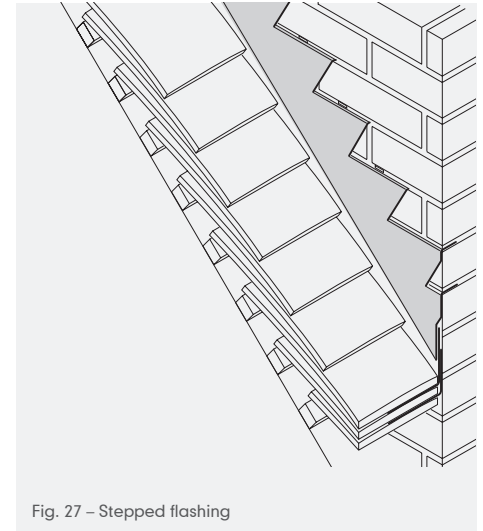

Fig. 27 – Stepped flashing

DRY SOAKERS

A range of BS 5534-compliant, easy-to-install polypropylene dry soakers is available as an alternative to lead. For details, see page 213.

FLASHINGS AND WEATHERINGS

SECRET GUTTER WITH COVER FLASHING

A secret gutter must be formed when using single lap flat interlocking tiles and slates. Maximum security can be achieved by a combination of both secret gutter and cover flashing.

- 1 Form secret gutters before starting tiling.
- 2 Fix a support between last rafter and abutment. This should be a minimum of 75mm wide and run the full length of abutment.
- 3 Fix a splayed timber fillet at discharge point to raise lead lining to the right height. Avoid backward falls (Fig. 28).
- 4 Fix counter batten along outer edge of rafter.
- 5 Line gutter with Code 4 or 5 lead, in lengths of not more than 1.5m.
- 6 Lap each strip offered over the lower one by a minimum 150mm and fix with copper nails at head.
- 7 Turn up lead welts to provide a weather check and exclude birds and vermin from entering tile batten space.

- 8 Gutter should be a minimum of 25mm deep and have a vertical upstand of no less than 65mm above top surface of the tiles or slates.
- 9 Fit a stepped flashing, chased into brickwork as before and dressed over vertical upstand.
- 10 Turn roofing underlay up side of counter battens and butt tiling battens up to counter batten.
- 11 Lay tiles to leave a gap of 15mm by the side of abutment (Figs. 29 and 30).

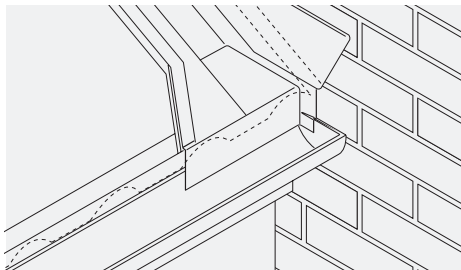

Fig. 28 – Secret gutter

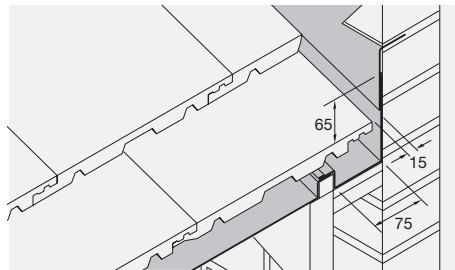

Fig. 29 – Secret gutter

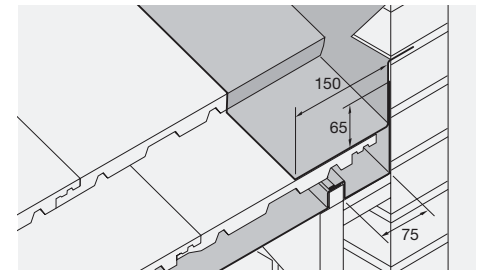

Fig. 30 – Completed secret gutter with cover flashing

FLASHINGS AND WEATHERINGS

DORMERS

Treat tiled dormer roofs in a similar way to the main roof work. However, single lap tiling is less suitable for small covered areas and for a dormer, it is generally preferable to adopt an alternative form of covering.

- 1 When dormer cheeks are tile hung, close cut vertical tiles to rake of roof over a flashing fixed to side of dormer and dress well into the adjacent tiles. Formation of a secret gutter is not recommended.

BACK GUTTERS

Back gutters may be lead welded off site and positioned when tiling is undertaken. A gutter should be formed where the bottom edge of tiling meets an abutment. Form the gutter before tiling, but after felting and battening is complete.

- 1 Fix a layboard to support lead lining, with a tilting fillet, close to abutment to flatten pitch of lead.
- 2 Dress a sheet of Code 5 lead (width of abutment plus 450mm) into position with a vertical upstand of at least 100mm up abutment.

- 3 Dress extra width of lead around corner of abutment after any side abutment weathering has been fitted.
- 4 Dress upper edge of lead over tilting fillet and turn it back to form a welt (Fig. 31).
- 5 Chase abutment, insert a cover flashing of Code 4 lead and dress it over vertical upstand of gutter.

ROOF PROTRUSIONS

The treatment of tiling against chimney stacks, skylights and other similar projections through the roof surface should be similar to that described for abutments where appropriate (Fig. 32).

- 1 Make perforations for pipes, chimney stays, supports for ladders etc. weathertight by dressing over and under tiling, with a lead or copper slate to which a sleeve is burned or soldered.
- 2 Boss sleeve around pipe or stay, and seal at top by a collar.

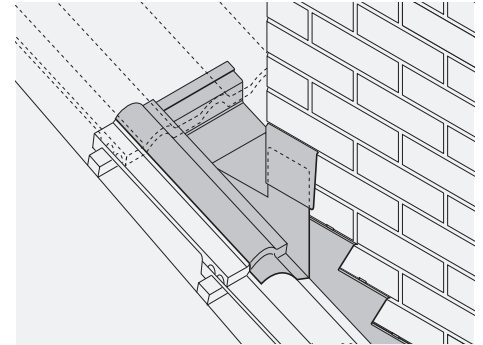

Fig. 31 – Back gutter

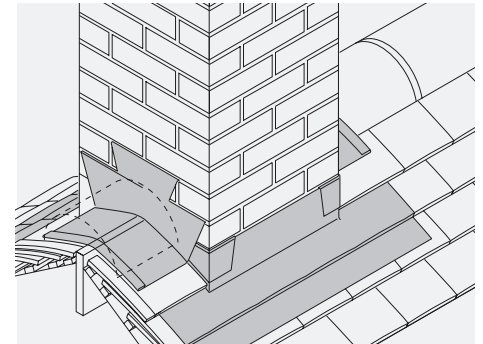

Fig. 32 – Roof chimney at ridge line

FLASHINGS AND WEATHERINGS

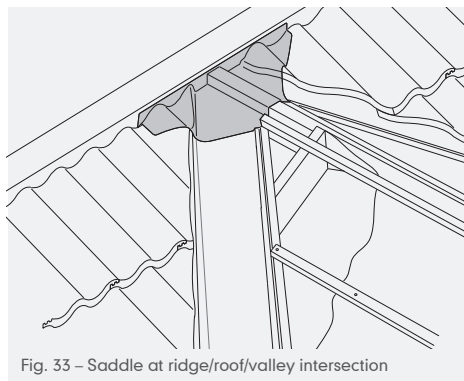

Fig. 33 – Saddle at ridge/roof/valley intersection

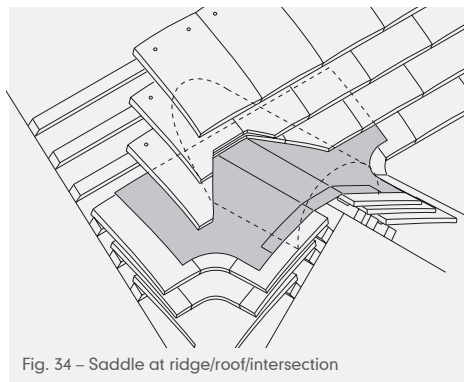

Fig. 34 – Saddle at ridge/roof/intersection

SADDLES

The following details can apply to any type of valley or hip/ridge intersection.

- 1 Use Code 4 lead (or Flexfast lead replacement roll) not less than 450mm etc. square and large enough to give a lap of at least 150mm over gutter lining on each side.
- 2 Saddles should be capable of being readily dressed down when in position (Figs. 33 and 34).

FIXINGS

Clips – clips for flashings are important in all roofing applications and where used should be fixed at 300-500mm centres, depending on the exposure of the building.

Clips may be formed from the following materials:

Lead – only suitable for sheltered locations with a thickness the same as that of the flashing it is fixing, as detailed by the Lead Sheet Association.

Copper – should be 0.6mm thickness (min.) and may be thicker for very exposed locations.

Stainless steel – should be 22swg or 28swg thickness and is used for very exposed locations or where the fixing point is more than 75mm from the free edge of the flashing.

NAILS AND SCREWS

Copper wire nails (with jagged shanks) should be a minimum 25mm long x 10 gauge. Stainless steel annular ring shank wire nails should be a minimum 25mm x 12 gauge. Screws should be brass or stainless steel, minimum 25mm long x 10 gauge.

FLASHINGS AND WEATHERINGS



Flashing and weathering check points*

- Lead can be difficult to work, particularly heavier codes. In cold weather take care not to split or puncture it whilst working.
- Always use proper lead working tools. Hammers are not recommended for dressing lead.
- Nail and/or clip all tiles and slates next to an abutment.
- Fillets of mortar are not recommended at abutments because cracking of mortar brings high risk of failure.
- Galvanized, aluminium, zinc and cut copper nails or tacks should not be used for fixing leadwork.
- Temporarily place a length of cloth beneath lead before dressing down onto lightweight tiles and slates to avoid breakage.
- Avoid contact with aluminium in a marine environment.
- Use patination oil to avoid lead staining.

* Full details on fixing and use of lead flashings and weatherings can be obtained from the Lead Sheet Training Academy: Unit 10, Archers Park, Branbridges Road, East Peckham, Tonbridge, Kent TN12 5HR. Tel: 01622 872432 www.leadsheet.co.uk

FIRE STOPPING

The spread of fire within a building or from one property to another can be restricted by providing compartments between one another by a fire resisting construction, one of the most common examples are separating walls between dwellings.

Shown below is general guidance for domestic situations only.

For further information on detailing separating walls between dwelling and other buildings that require a fire resistance please refer to the Building Regulations Approved Document B and/or consult with your local authority Building Control Department.

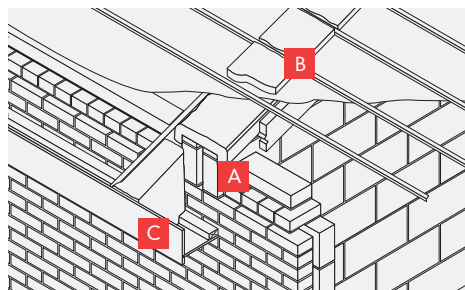

Fig. 35 – Separating wall with fire stop

SEPARATING WALL JUNCTION WITH ROOF

The use of a mortar bedding trowelled onto the wall under and between the battens is not recommended, as gaps are often left under the tiles. Additionally, if differential settlement occurs, this will lead to hogging or humping of the roof tiling above the separating wall.

It is recommended that a mineral wool (or similar compressible material) with fire resistant properties, to meet Part B of the Building Regulations, is selected to limit the spread of smoke and fire.

The following points should be adopted to ensure a satisfactory detail:

- 1 When trimmed to roof slope, ensure that party wall is 25mm below top edge of adjacent rafters. Mortar if necessary to achieve a fair line.
- 2 Before felting and battening, ensure fire stopping material (A) is laid on top of wall with edges tucked between wall faces and adjoining rafters.

- 3 After felting and battening, ensure lengths of fire stopping material (B) are laid between battens as tiling proceeds or fixed by spot sticking in place before tiling.
- 4 Check eaves void is filled with fire stopping material (C) to achieve a tight fit.
- 5 Fire resistant material must be securely fixed without support from the soffit board (Fig. 35).
- 6 Proprietary intumescent fire barriers may be used as an alternative or in conjunction with mineral wool (see page 221 – Roof Defence).

Note: Prior to starting work, it is recommended that the Local Authority Building Control Officer is contacted to confirm approval of the proposed work.

RIGID BOARDING/SARKING AND COUNTER BATTENS

In Scotland, some parts of Northern England, and for some types of timber construction, it is traditional to fix rigid or semi-rigid boarding or sarking directly above the rafters.

Boarding or sarking may consist of tongue and grooved or square edged timber boards, plywood, wood wool slabs, fibreboard, particle board, orientated strand board (OSB) or cement particle board as specified in BS 5534.

When using boarding or sarking, it is necessary to fit counter battens above* to provide a drainage path to the eaves gutter beneath the battens for any moisture that may have accumulated beneath the roof covering. The fixings for boards, battens and counter battens should be of sufficient length to resist the design wind loadings, but should provide at least 40mm penetration into the rafter or support and be of at least 3.35mm dia.

* Min. 19mm depth (to prevent the batten splitting upon nailing).

The following is a summary of general requirements to be considered when using rigid sarking or boarding:

- When completing groundwork on roof, first lay underlay onto the sarking boards lapped horizontally and vertically in accordance with guidance shown on pages 12-19.
- Fix counter battens through sarking into rafters by at least 40mm.
- Nail battens above counter battens at required tiling gauge.
- Allow for extra thickness of counter battens and sarking at eaves when fixing fascia or tilting fillet, and at verge, by building up outer layer of brickwork.
- Cut the rigid sarking back at inner leaf of brickwork.
- Lap underlay at ridge over apex and finish sarking and counter battens 15mm short of this apex.

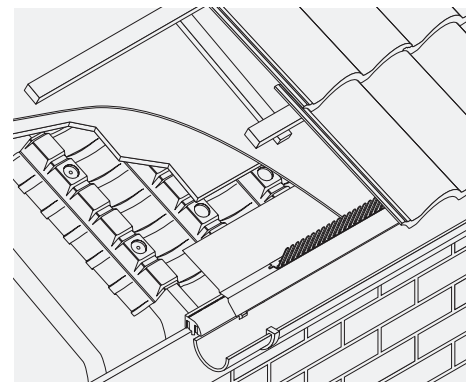

Fig. 36 – Battens and counter battens at eaves above rigid boarding and underlay

- Where ventilated dry fix ridge systems are used, cut sarking and underlay back to provide ventilation.
- The fixing of all tiles should comply with BS 5534 and a site specific fixing specification.

RIGID BOARDING/SARKING AND COUNTER BATTENS

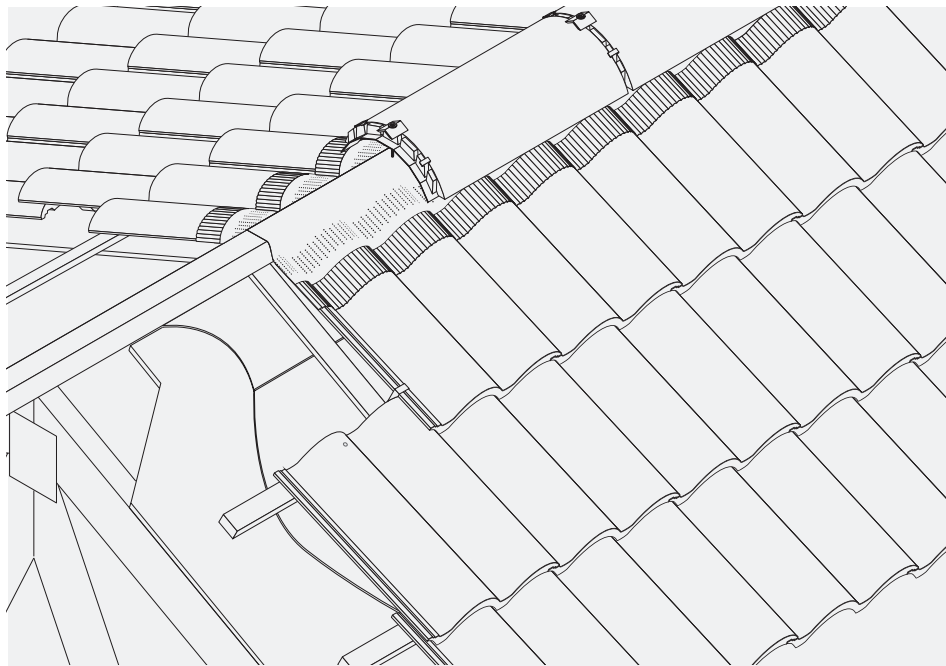

Fig. 37 – Battens and counter battens at ridge above rigid boarding and underlay (cut back at apex), with Marley ventilated dry ridge system

The use of the roof as a habitable space may require insulation boards laid above and/or between the rafters to provide the required thermal insulation. This type of construction will often require the use of counter battens with specialist fixings to the roof structure.

The roof should be designed to meet the recommendations of BS 5250 'moisture management in buildings – Code of practice', incorporating an Air and Vapour Control Layer (AVCL) and adequate roof ventilation provisions.

Other proprietary tile support systems may be used and should be fixed in accordance with the manufacturer's recommendations.

FIXING MATERIALS

TILE FIXINGS

To guard against 'nail sickness', BS 5534 recommends the use of aluminium or stainless steel nails under normal conditions of exposure. Galvanized nails should be used for fixing to rafters etc., be used for fixing battens to rafters, but care must be exercised when there is high humidity, or where it is known that certain timber preservative treatments may corrode steel, zinc or aluminium. In such cases, stainless steel nails should be used.

All Marley tile fixings have been tested to the requirements of BS 5534 which includes a test method to establish the resistance of clips, nails and hooks to wind uplift.

TILE NAILS

Nails for use with tiles should be of copper, aluminium, stainless steel, phosphor or silicon bronze. Aluminium nails intended for use with tiles should conform to BS 1202-3 and should be clout head nails of 3.35mm or 2.65mm diameter. The length of nail will be determined by the required wind uplift and the design of the tile. 3.35mm for single-lap tiles (Fig. 39) or 2.65mm for plain tiles (Fig 38).

Stainless steel nails for use with tiles should conform to BS EN 10088-3, grade 302, 304, 315, 316, 321 or 347, and are recommended for coastal areas, areas of high exposure, or where there is a risk from chemical reaction.

BATTEN NAILS

Nails for use with battens, counter battens and boarding (board sarking) should conform to BS EN 10230-1. They may be uncoated or, for extra protection and in coastal regions, coated by zinc or zinc alloy coating methods specified in BS EN 10230-1.

UNDERLAY NAILS

Nails for use with roofing underlays should be clout head nails of not less than 3.0mm shank diameter and 20mm length made of copper; aluminium alloy or steel coated by any of the zinc or zinc alloy coating methods specified in BS EN 10230-1.

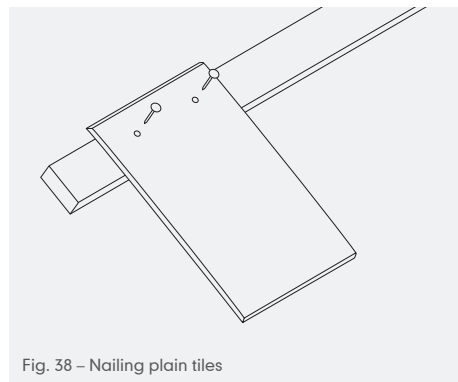

Fig. 38 – Nailing plain tiles

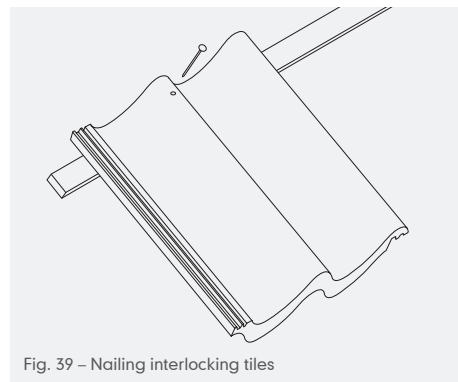

Fig. 39 – Nailing interlocking tiles

FIXING MATERIALS

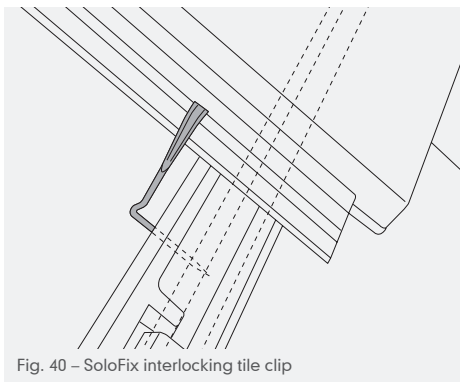

Fig. 40 – SoloFix interlocking tile clip

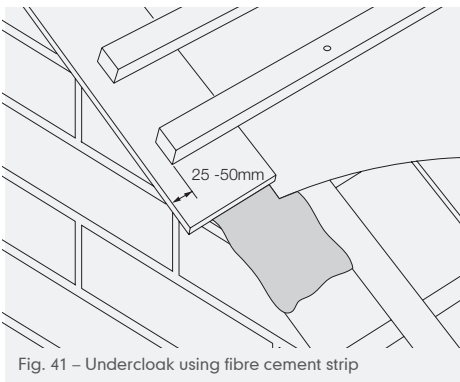

Fig. 41 – Undercloak using fibre cement strip

SOLOFIX TILE CLIPS

Marley now offers, as standard, SoloFix tile clips as an improved means of meeting the greater requirements for clipping stipulated by BS 5534. Made from a unique material called ZiAl, these one-piece clips are 30% quicker to install than their traditional equivalent and can be used in all areas of exposure in the UK.

All Marley proprietary fixings are fully tested and exceed the requirements of BS 5534 in terms of material specification and strength.

SECRET CUT TILE CLIPS

A clip to provide secure mechanical fixing of small pieces of cut tile at hip, valley and other areas where normal fixings are untenable. Compliant with BS 5534.

UNDERCLOAK

Where an undercloak is used as a support for mortar bedding it may take the form of a fibre cement sheet strip 1200mm long x 150mm wide with a roughened surface to assist the mortar bond (Fig. 41).

SLATER'S TUB

- All the fixings you need in a tub
- Perfectly shaped to sit safely on roof
- 2000 copper nails (30 x 2.65mm gauge)
- 1000 copper disc rivets
- Complies with BS 5534



Roofing fixing spec

A tool to create fixing specifications based on the geographical location and building dimensions of specific building projects: marley.co.uk/tilefix

FIXING MATERIALS

MORTAR

The mortar used in roof construction should conform to the recommendations given in BS 5534 (Table 6). Mortar should typically consist of the following mixes:

- 1 3:1 with blended sand: Soft sand and sharp sand mix, with the sharp sand making up no less than one third of the sand content, to one part Portland cement and plasticizer in accordance with manufacturers' instructions.
- 2 3:1 with coarse building sand: Some building sands are coarse in nature and have been found to have a size particle distribution in line with a blended mix of fine building sand and sharp sand. Where 70% to 90% of the sand is able to pass through a 0.5mm sieve, this may be used as part of a 3:1 sand cement mix with plasticizer, in accordance with manufacturers' instructions.

Notes: If the use of other mixes is being considered, attention needs to be given to workability of the mix and possible application problems, e.g. the need to avoid unsatisfactory bedding on steep pitches. Guidance on the use of mortar is given in NFRC Technical Bulletin 27 [12].

MORTAR BEDDED APPLICATIONS

- Check correct mortar mix for bedding tiles and fittings.

The following is good practice:

- Wet all products prior to bedding.
- Ensure all bedding surfaces are clean and free from harmful matter.
- Apply a bonding agent to the surface of smooth faced tiles to improve mortar bond.

IMPORTANT: The use of mortar for bedding tiles may be affected by differential movement of the roof structure causing the bond between roof element and tile or slate to be compromised.

BS 5534 states that all mortar bedding must now be accompanied by a mechanical fix.

Fixing materials check points

- Nails used to fix tiles should be driven home and/or firmly secured into the centre of the batten or timber to which they are fixed in order to maximise their effect in use.
- Clips used to fix tiles should be located and aligned so as to fit correctly onto the appropriate interlock/headlock in order to maximise their effect in use.
- Clips used to secure verge and valley tiles or slates should be twice nailed to the top of the batten or timber to which they are fixed, with the top of the clip firmly securing the edge of the tiles.
- Always check the fixing specification before starting to lay tiles. If in doubt nail and clip each tile or slate to ensure maximum security.
- All tile nails and clips should penetrate the batten by no less than 15mm

MORTAR BEDDED HIPS AND RIDGES

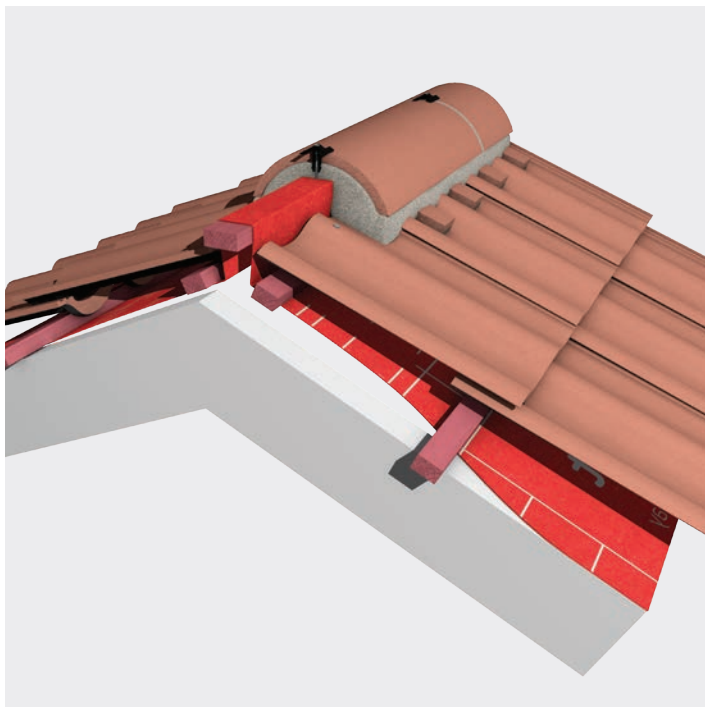

DUO-PITCH RIDGES

Ridges should be covered using ridge tiles of complementary colour, or contrasting, and texture to that of main roof tiles. Always check that the ridge tile design suits the pitch and type of roof tile being used.

- For interlocking tiles, a minimum of 75mm cover should be provided over top course tiles.
- For plain tiles, a minimum of 65mm cover should be provided over the last full course of tiles.
- Exposed mortar should be neatly pointed.

MORTAR BEDDED RIDGES

- 1 Felt and batten roof in the normal way, but before fixing the top course battens, secure a ridge batten bracket to each rafter centrally at apex using the nails supplied.

To establish the point to bend the legs of the ridge batten bracket, parallel to the rafters, a short length of top course batten should be temporarily nailed into place either side of the ridge, onto which a tile is laid. Position a ridge tile centrally

onto the roof tiles and offer up a ridge batten bracket against the rafter. The bracket should be bent at the best position to achieve a minimum 20mm screw penetration into the ridge tree (1 or 2 tiling battens) (Fig. 1). For Marley tiles, refer to the batten setting height table and Fig. 7, page 41.

Place the ridge batten(s) along the length of the ridge between the perforated straps of the ridge batten brackets. Bend over the straps and nail securely to the ridge

batten using the nails supplied. Joints in the battens should be made over a bracket to ensure the ends are secured.

- 2 Lay the top edges of the roofing underlay (or additional length) loosely over the ridge batten and secure the top course battens such that the appropriate ridge tile headlap can be maintained (Fig. 2).
- 3 Finish tiling the roof up to the ridge (Fig. 3).

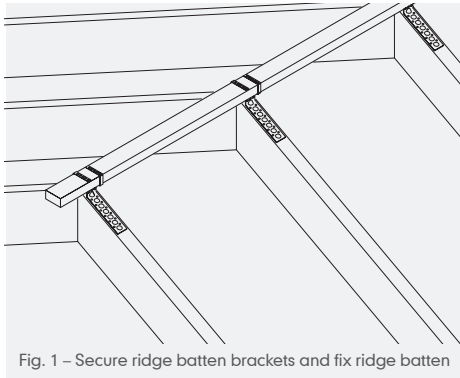

Fig. 1 – Secure ridge batten brackets and fix ridge batten

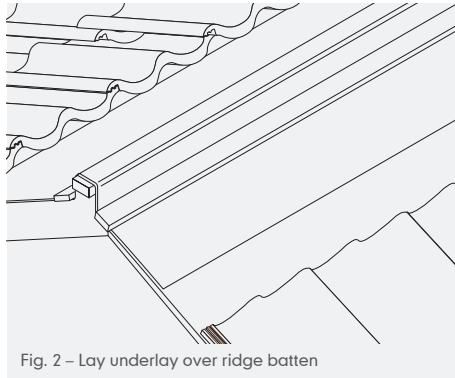

Fig. 2 – Lay underlay over ridge batten

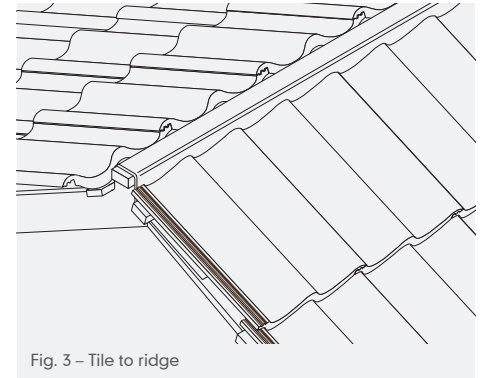

Fig. 3 – Tile to ridge

MORTAR BEDDED RIDGES

- 4 Edge bed the ridge tiles along the roof in the normal way using dentil slips where needed and solid bed the butt joints (Fig. 4).
- 5 To mechanically fix the ridge tiles push a plastic ridge clamp centrally between the ridge tiles into the wet mortar and secure in place by driving the 75mm stainless steel screw provided into the ridge batten. Do not over tighten (Fig. 5). When using clay ridge with interlocking pantiles, you will require a 100mm deep ridge screw pack (Code 70000, sold separately).
- 6 Repoint any displaced mortar at the ridge tile joints.
- 7 End ridge tiles need to be secured by drilling a 6mm dia. hole through the ridge tile, 100mm from the open end, and driving one of the 75mm long s/steel screws supplied into the ridge batten (Fig. 6).

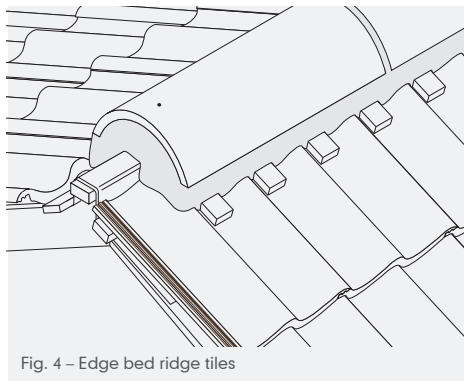

Fig. 4 – Edge bed ridge tiles

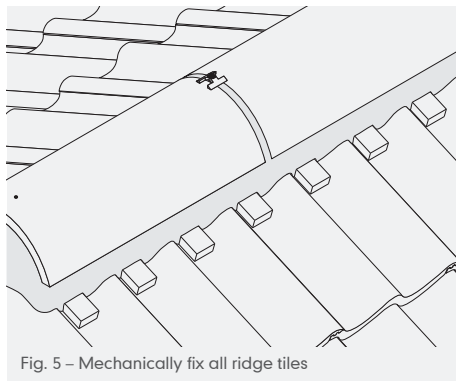

Fig. 5 – Mechanically fix all ridge tiles

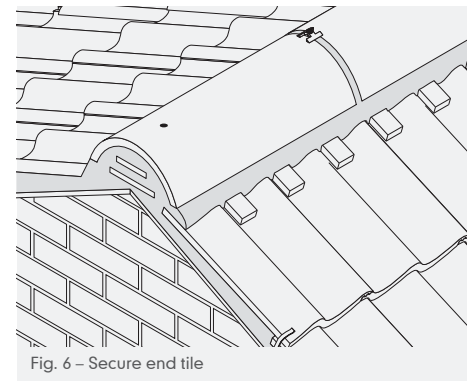

Fig. 6 – Secure end tile

MORTAR BEDDED RIDGES

BATTEN HEIGHT SETTING*

The first figure gives ridge batten height (in mm). The figure in brackets gives hole positions at which ridge batten bracket legs are bent across centres of larger holes to fix to rafter

Tile	Ridge type	Roof pitch											
		12.5°	15°	17.5°	22.5°	25°	30°	35°	40°	45°	50°	55°	60°
Anglia	Segmental Ridge			50 (4)	50 (3)	50 (3)	50 (3)	50 (3)	50 (2)	50 (2)	50 (1)	50 (1)	50 (1)
Ashmore	Segmental Ridge				50 (1)	50 (1)	50 (1)	50 (1)	25 (1)	25 (1)			
	Modern Ridge				50 (1)	50 (1)	50 (1)	50 (1)	25 (1)	25 (1)			
Concrete Plain	Segmental Ridge							50 (2)	50 (1)	50 (1)	25 (1)	25 (1)	25 (1)
	Modern Ridge							50 (1)	50 (1)	25 (2)	25 (1)	25 (1)	
Double Roman	Segmental Ridge			50 (3)	50 (2)	50 (2)	50 (2)	50 (1)	50 (1)	25 (2)	25 (1)	25 (1)	
Eden	Segmental Ridge			50 (4)	50 (3)	50 (3)	50 (3)	50 (3)	50 (2)	50 (2)	50 (1)	50 (1)	50 (1)
Edgemere range	Segmental Ridge			50 (2)	50 (1)	50 (1)	50 (1)	50 (1)	25 (1)	25 (1)	25 (1)		
	Modern Ridge			50 (2)	50 (1)	50 (1)	50 (1)	50 (1)	25 (1)	25 (1)			
Fibre cement slates	Segmental Ridge		50 (1)	50 (1)	50 (1)	50 (1)	50 (1)	25 (1)	25 (1)				
	Modern Ridge		50 (1)	50 (1)	50 (1)	50 (1)	25 (1)	25 (1)					
Lincoln	Segmental Ridge			50 (4)	50 (3)	50 (3)	50 (3)	50 (3)	50 (2)	50 (2)	50 (1)	50 (1)	50 (1)
Ludlow Plus	Segmental Ridge				50 (2)	50 (2)	50 (1)	50 (1)	50 (1)	25 (1)	25 (1)		
	Modern Ridge				50 (2)	50 (2)	50 (1)	50 (1)	25 (1)	25 (1)			
Ludlow Major	Segmental Ridge			50 (2)	50 (2)	50 (2)	50 (2)	50 (1)	50 (1)	25 (1)	25 (1)	25 (1)	
	Modern Ridge			50 (2)	50 (2)	50 (2)	50 (1)	50 (1)	50 (1)	25 (1)	25 (1)		
Mendip/Wessex	Segmental Ridge		50 (3)	50 (3)	50 (3)	50 (3)	50 (2)	50 (2)	50 (1)	50 (1)	50 (1)	25 (1)	25 (1)
	Modern Ridge		50 (3)	50 (3)	50 (3)	50 (2)	50 (2)	50 (2)	50 (1)	50 (1)			
Modern/Duo Modern	Segmental Ridge			50 (2)	50 (2)	50 (2)	50 (1)	50 (1)	25 (1)	25 (1)	25 (1)		
	Modern Ridge			50 (2)	50 (1)	50 (1)	50 (1)	25 (2)	25 (1)	25 (1)			
Natural slates	Segmental Ridge		50 (1)	50 (1)	50 (1)	50 (1)	50 (1)	25 (1)	25 (1)				
	Modern Ridge		50 (1)	50 (1)	50 (1)	50 (1)	25 (1)	25 (1)					

* Please note that this table is a guide only - not site specific - based on the requirement to provide a minimum 15mm penetration as stated in BS5534. For further information please contact our technical team on the following 01283 722330.

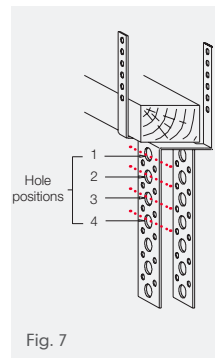

Fig. 7
Note: Bracket legs should be bent across the centres of the larger holes, as indicated by the dotted red lines.

MORTAR BEDDED HIPS

- 1 Felt and batten roof in the normal way, mitring the tiling battens at the hip. Secure the mitred ends to the hip tree or continuous structural member.
- 2 Fix a galvanised hip iron, minimum 4mm thick, at the base of the hip tree with two 5mm diameter nails or suitable screws.
- 3 Tile roof leaving an 80mm gap between the raking cut tiles and slates laid adjacent to the hip tree. Ensure all raking cut tiles and slates are fully supported on the battens and if not, provide suitable packers to prevent tiles from rocking.
- 4 Ensure that all raking cut tiles and slates along the length of the hip are fully secured using the 'C' clips provided or secret cut tile clips (Code 43607, sold separately).
- 5 Fix hip batten brackets to the hip tree using 4 nails per bracket at approx. 550mm centres.
- 6 Position the first bracket immediately above the hip iron and the topmost bracket no more than 100mm from the hip/ridge apex. (When fixing Plain tiles the tiling battens will require trimming back from hip tree, locally, to provide space for fitting batten brackets. Support the free batten ends with noggins.)
- 7 Batten brackets can be fitted at a choice of 2 heights achieved by bending the bracket legs inwards along the appropriate diagonal line of holes (see page 44).

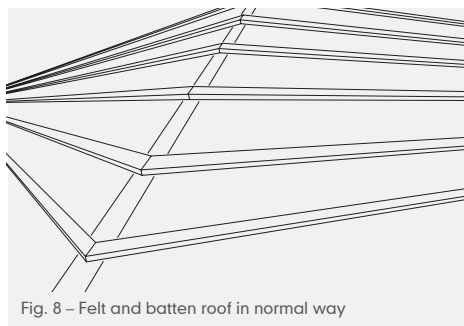

Fig. 8 – Felt and batten roof in normal way

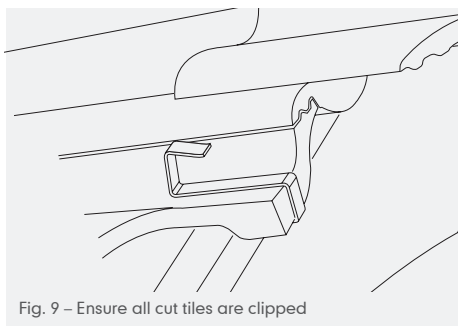

Fig. 9 – Ensure all cut tiles are clipped

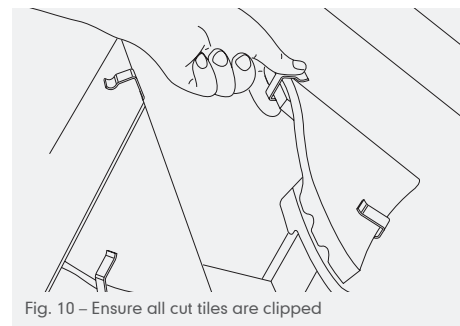

Fig. 10 – Ensure all cut tiles are clipped

MORTAR BEDDED HIPS

- Secure either one or two thicknesses of 50mm x 25mm tiling batten to the top of the batten brackets, parallel to the hip rafter, by folding over bracket arms and nailing through perforations into the battens.
- Where 2 depths of batten are needed ensure they are secured to each other before locating into the batten brackets. Joints in the hip battens should be made over a batten bracket so both free ends can be secured.

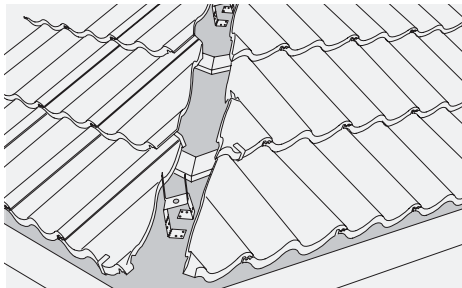

Fig. 11 – Fix batten brackets

Note: To establish whether one or two batten thicknesses are needed, place a hip tile in situ over the hip tree, at the highest point of the roof tiling, and assess the space remaining between the top of the batten bracket and underside of the hip tile. Install two battens if two fit without fouling the hip tile.

- The first hip tile needs to be placed against the hip iron, shaped to the line of the eaves and secured by drilling a 6mm dia. hole through the tile, 100mm from the open end, and driving one of the 75mm long stainless steel screws supplied into the hip batten.

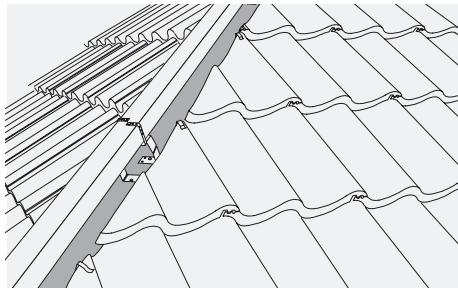

Fig. 12 – Fix hip batten

Fill the open end with mortar inset with pieces of tile. Neatly point. When using clay hip with interlocking pantiles, you will require a 100mm deep ridge screw pack (Code 70000, sold separately).

- Edge bed the hip tiles onto roof tiling and mechanically fix each as they are laid.
- To mechanically fix the ridge tiles, drive one of the stainless steel screws supplied through the slot in a capped angle ridge clip and hole in the end of the tile into the hip batten. Do not over tighten.

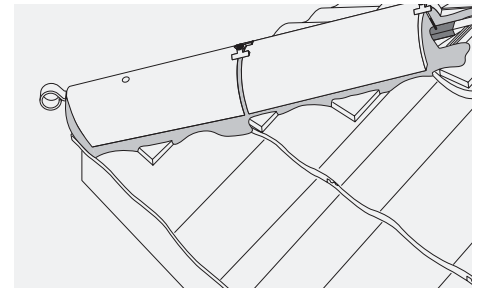

Fig. 13 – Mechanically fix hip tiles

MORTAR BEDDED HIPS

- 13 Slide the adjacent ridge tile into the open end of the clip and secure the opposite end with a clip and screw. Continue this procedure up the length of the hip.
- 14 The topmost hip tiles need to be secured by drilling a 6mm dia. hole through the hip tile, 100mm from the open end, and driving one of the 75mm long stainless steel screws supplied into the ridge batten.

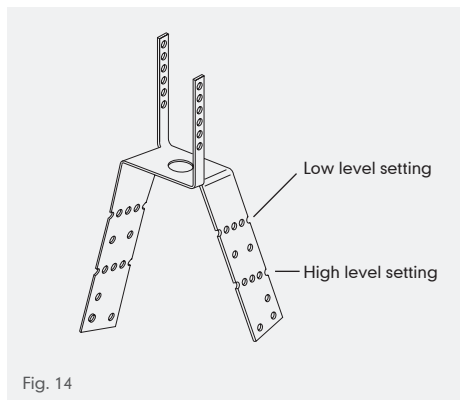

Fig. 14

BATTEN BRACKET SETTING TABLE FOR MARLEY ROOF TILES*

Low level batten bracket setting (bend along top row of diagonal holes)

 Ashmore

 Duo Edgemere (above 25° pitch)

 Edgemere (above 25° pitch)

 Ludlow Major (above 32.5° pitch)

 Ludlow Plus

 Plain

High level batten bracket setting (bend along bottom row of diagonal holes)

 Anglia

 Double Roman

 Duo Edgemere (17.5° to 25° pitch)

 Duo Modern

 Eden

 Edgemere (17.5° to 25° pitch)

 Lincoln

 Ludlow Major (22.5° to 32.5° pitch)

 Mendip

 Modern

 Wessex

* Apply same settings for other manufacturers' equivalent tile profiles.

REPAIR AND REPLACEMENT

ROOF RENEWAL DETAIL

Renewal of roof covering on semi-detached or terraced properties may lead to different tiles or slates being installed than those on a neighbouring property. An effective method of weathering this junction is to use a Marley GRP dry bonding gutter system as shown in Fig. 1.

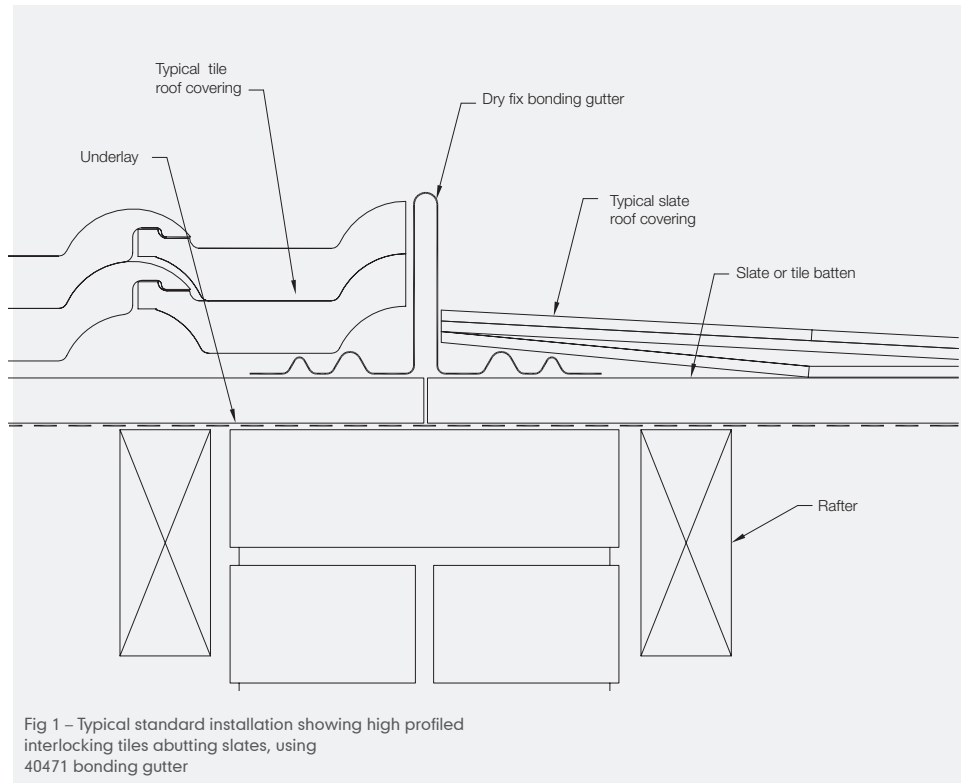

REPAIR AND REPLACEMENT

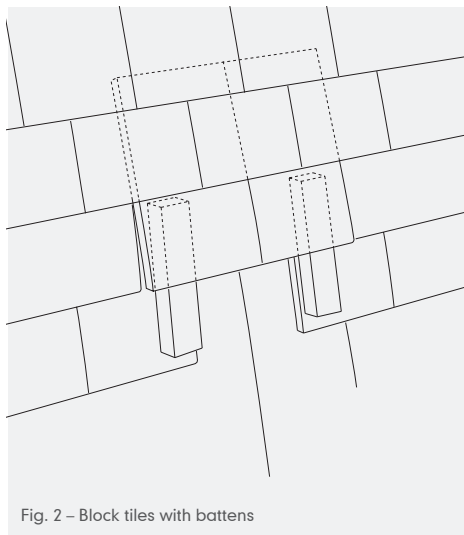

Fig. 2 – Block tiles with battens

PLAIN TILES

Plain tiles are not normally nailed in every course, and in such circumstances the following procedure applies:

- 1 Remove damaged tile by raising up the tiles with a timber wedge or trowel and sliding out the tile with the nibs clearing the top of the batten. Any nails should be removed and disposed of safely (Fig. 2).
- 2 Insert replacement tile back into position using the same technique in reverse. If required, re-nail the replacement tile using 2 No. 38mm x 2.65mm aluminium nails.

Suitable adhesive can be placed on the underside to prevent movement.

INTERLOCKING TILES

Individual tiles or slates that are damaged during or after installation should be replaced as soon as possible using a sound matching unit fixed in accordance with the nailing and/or clipping specification. In some cases, this may not be possible without stripping back a large area of tiling/slating.

Superficial coatings or repairs to damaged units using adhesives or other mechanical devices should not be used as their long term performance may be limited.

If extensive repairs to the roof are required, sectional or complete re-tiling/slating should be considered, as this may be the most practical and economic solution.

Roofs and walls clad with tiles and slates should be treated as fragile, and adequate precautions should be taken, including the use of crawling boards and roof ladders (suitably packed to prevent damage to the roof covering) or access platforms when accessing the roof for the purposes of maintenance or repair.

REPAIR AND REPLACEMENT

Failure to use adequate access equipment can damage the tiles and fixings and may be in contravention of Health and Safety Regulations.

- For a tile that is nailed, the neighbouring tiles should be lifted to expose the nail(s), which should be extracted carefully using a slate ripper or hacksaw blade and disposed of safely. The replacement tile can be inserted using the same procedure and re-fixed to the adjacent fixed tiles by using an epoxy resin adhesive applied to the interlock/overlock and head lap area. Care must be taken not to bridge anti-capillary bars or interlocking water channels so that water can drain freely.
- For a tile that is clipped, the clip can be prised off the interlock and the nail extracted, with the damaged tile removed as described above. The new SoloFix clip can then be fitted as normal (avoiding the previous nail hole), allowing the clip to rest in the clip recess of the adjacent tile. Hold up the clip, and slide the replacement tile into position, allowing the clip to be released onto the sidelock of the tile.
- For a tile that is both nailed and clipped, it is necessary to establish the position of the tile nail holes of the course directly below the replacement tile. Mark out the corresponding hole positions on the top surface near the tail of the tile. Fit the replacement using the above procedure. Drill a 4mm dia. hole through the top of the replacement tile, directly above the nail hole of the tile below. Secure both courses using a stainless steel screw with cap and washer (40-120mm long dependent on tile depth) to provide a minimum 15mm penetration into batten.
- The above procedure can also be used to secure the tail of the course above the replacement tile.
- If there are a number of damaged tiles that are clipped, it may be necessary to strip back the roof to the nearest verge or valley/hip in order to re-clip the replacement tiles.

Note: It is important that both washer and cap form a waterproof seal around the hole. If necessary, a mastic sealant should be applied around the screw where it passes through the lower tile nail holes.

For individual tiles, some adhesives can be used. Install in accordance with manufacturer's guidelines.



SOLARTILE®

- 49 Orientations
- 55 Electrical
- 56 Fixing guidance
- 57 Installation overview
- 58 Tile battens
- 59 Installation sequence

Note, that the following instructions (pages 49 – 80) are for the installation of the 410Wp Marley SolarTile®. Further guidance for 335Wp panel installations can be found at marley.co.uk/solar



SOLARTILE® ORIENTATIONS – G1 335

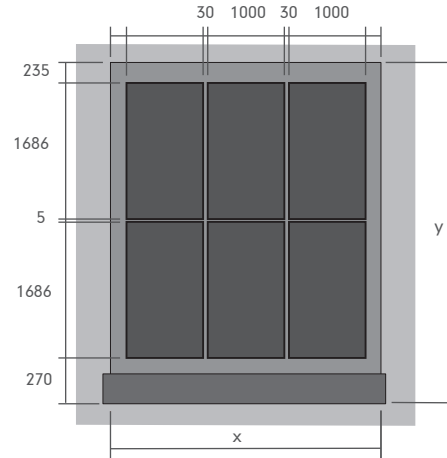
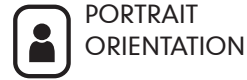
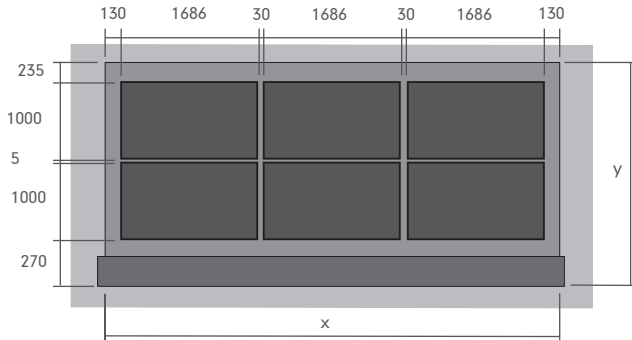

SolarTile®	G1 335
X	$(m \times 1030) + 230$
Y	$(n \times 1691) + 500$
Width	1000
Length	1686

SOLARTILE® ORIENTATIONS – M10 410



LANDSCAPE
ORIENTATION

n x m

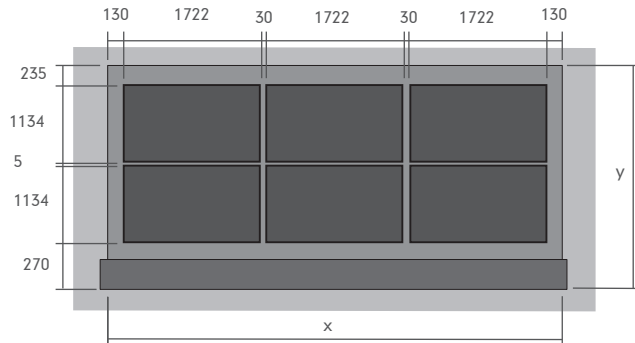
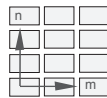

PORTRAIT
ORIENTATION

n x m

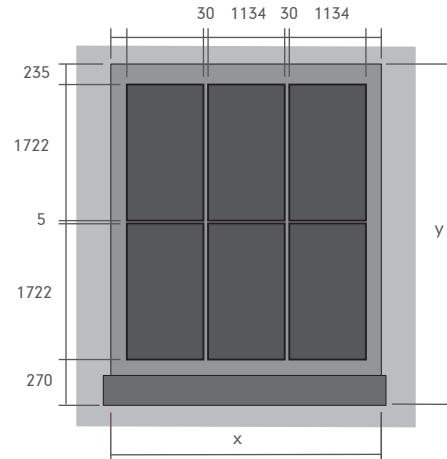
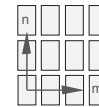

SolarTile®	M10 410
X	$(m \times 1164) + 230$
Y	$(n \times 1727) + 500$
Width	1134
Length	1722



PORTRAIT ORIENTATION

n x m

□ Marley SolarTile®	(n x m)
■	1
■ MAF16-TC	(m-2)
■ MAF16-TR	1
■ MAF16-TY	(n-1)
■ MAF16-J	(n-1) x (m-1)

1 x 2

□ Marley SolarTile®	2
■ MAF16-TL	1
■ MAF16-TR	1

1 x 4

□ Marley SolarTile®	4
■ MAF16-TL	1
■ MAF16-TC	1
■ MAF16-TR	1

Codes
Add G1 or M10 410 to complete codes.

For example
MAF16-TLG1 or
MAF16-TLM10 410

2 x 1

□ Marley SolarTile®	2
■ MAVAT16	1
■ MAF16-TY	1

2 x 2

□ Marley SolarTile®	4
■ MAF16-TL	1
■ MAF16-TC	0
■ MAF16-TR	1
■ MAF16-TY	1
■ MAF16-J	1

2 x 3

□ Marley SolarTile®	6
■ MAF16-TL	1
■ MAF16-TC	1
■ MAF16-TR	1
■ MAF16-TY	1
■ MAF16-J	2

2 x 4

□ Marley SolarTile®	8
■ MAF16-TL	1
■ MAF16-TC	2
■ MAF16-TR	1
■ MAF16-TY	1
■ MAF16-J	3

3 x 3

□ Marley SolarTile®	9
■ MAF16-TL	1
■ MAF16-TC	1
■ MAF16-TR	1
■ MAF16-TY	2
■ MAF16-J	4

PORTRAIT ORIENTATION

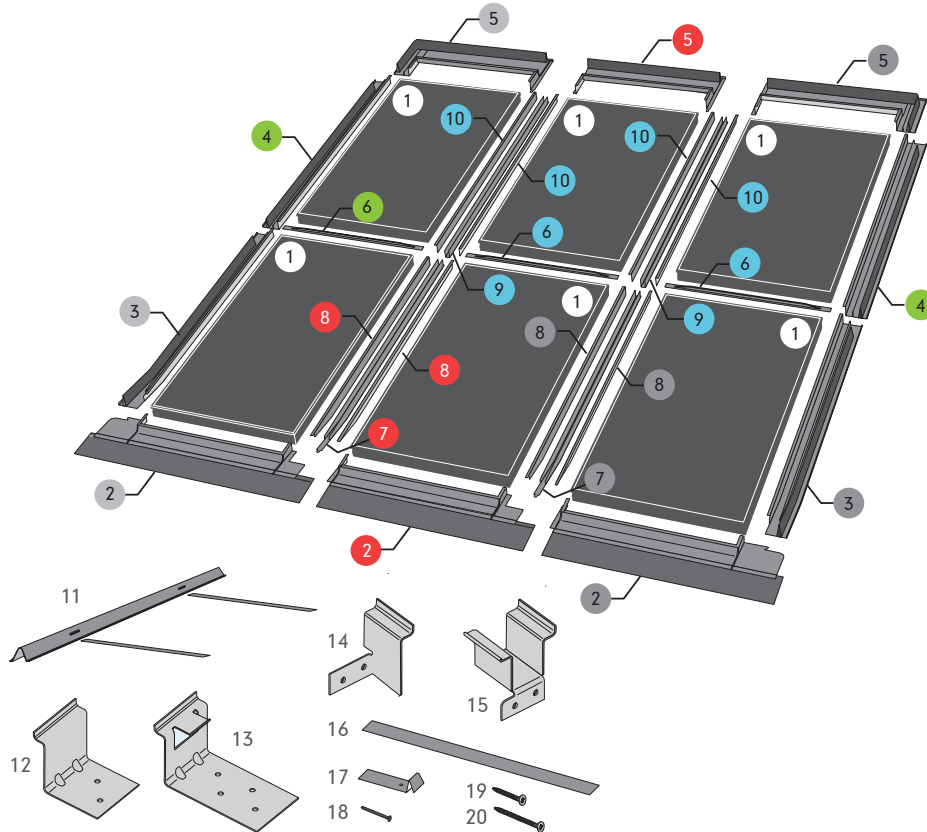

	TL	TC	TR	TY	J
1 Marley SolarTile® PV16					
2 Sill flashing	1	1	1		
3 Lower side flashing	1		1		
4 Upper side flashing				2	
5 Top flashing	1	1	1		
6 Joining strip				1	1
7 Lower gutter	1		1		
8 Lower gutter cover	2		2		
9 Upper gutter					1
10 Upper gutter cover					2
11 Tile support	1	1	1		
12 Rafter bracket	4	4	4		
13 Combi rafter bracket	2		2		
14 Batten bracket	3		3	6	
15 Combi batten bracket	3	3			3
16 Gutter fixing strip		1	1		1
17 Side fixing tab	6		6	12	
18 Nail	6	1	7	12	1
19 4 x 25mm screw	6	6	12	12	6
20 4 x 50mm screw	8	8	8	8	8



LANDSCAPE ORIENTATION

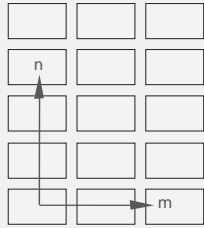

n x m

<input type="checkbox"/>	Marley SolarTile® (n x m)	
<input type="checkbox"/>	MAF16-TL	1
<input type="checkbox"/>	MAF16-TC	(m-2)
<input type="checkbox"/>	MAF16-TR	1
<input type="checkbox"/>	MAF16-TY	(n-1)
<input type="checkbox"/>	MAF16-J	(n-1) x (m-1)

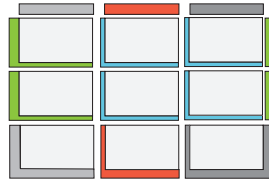

3 x 3

<input type="checkbox"/>	Marley SolarTile®	9
<input type="checkbox"/>	MAF16-LL	1
<input type="checkbox"/>	MAF16-LC	1
<input type="checkbox"/>	MAF16-LR	1
<input type="checkbox"/>	MAF16-LY	2
<input type="checkbox"/>	MAF16-LJ	4

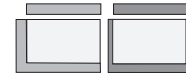

1 x 2

<input type="checkbox"/>	Marley SolarTile®	2
<input type="checkbox"/>	MAF16-LL	1
<input type="checkbox"/>	MAF16-LR	1

Codes

Add G1 or M10 410 to complete codes.

For example
MAF16-TLG1 or
MAF16-TLM10 410

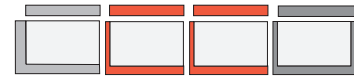

1 x 4

<input type="checkbox"/>	Marley SolarTile®	4
<input type="checkbox"/>	MAF16-LL	1
<input type="checkbox"/>	MAF16-LC	1
<input type="checkbox"/>	MAF16-LR	1

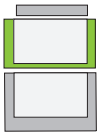

2 x 1

<input type="checkbox"/>	Marley SolarTile®	2
<input type="checkbox"/>	MAVAL16	1
<input type="checkbox"/>	MAF16-LY	1

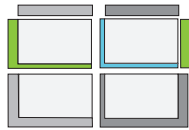

2 x 2

<input type="checkbox"/>	Marley SolarTile®	4
<input type="checkbox"/>	MAF16-LL	1
<input type="checkbox"/>	MAF16-LC	0
<input type="checkbox"/>	MAF16-LR	1
<input type="checkbox"/>	MAF16-LY	1
<input type="checkbox"/>	MAF16-LJ	1

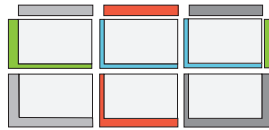

2 x 3

<input type="checkbox"/>	Marley SolarTile®	6
<input type="checkbox"/>	MAF16-LL	1
<input type="checkbox"/>	MAF16-LC	1
<input type="checkbox"/>	MAF16-LR	1
<input type="checkbox"/>	MAF16-LY	1
<input type="checkbox"/>	MAF16-LJ	2

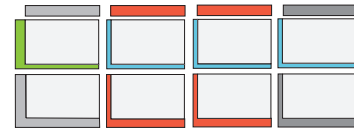

2 x 4

<input type="checkbox"/>	Marley SolarTile®	8
<input type="checkbox"/>	MAF16-TL	1
<input type="checkbox"/>	MAF16-TC	2
<input type="checkbox"/>	MAF16-TR	1
<input type="checkbox"/>	MAF16-TY	1
<input type="checkbox"/>	MAF16-J	3

LANDSCAPE ORIENTATION

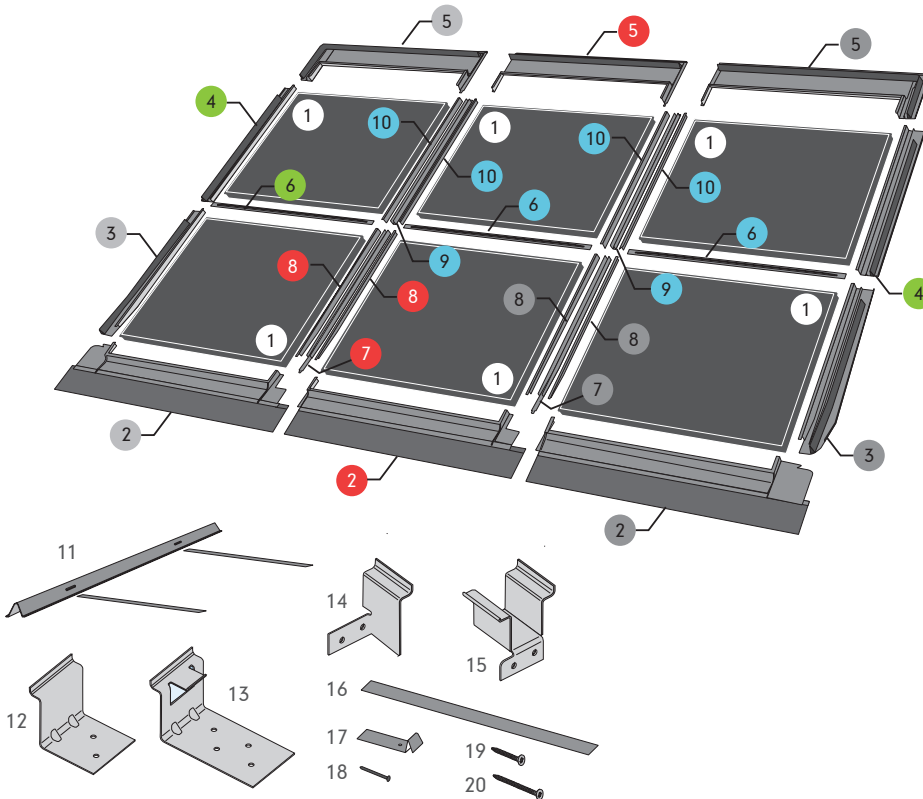

	LL	LC	LR	LY	LJ
1 Marley SolarTile PV16					
2 Sill flashing	1	1	1		
3 Lower side flashing	1		1		
4 Upper side flashing				2	
5 Top flashing	1	1	1		
6 Joining strip				1	1
7 Lower gutter		1	1		
8 Lower gutter cover		2	2		
9 Upper gutter					1
10 Upper gutter cover					2
11 Tile support	1	1	1		
12 Rafter bracket	6	6	6		
13 Combi rafter bracket				3	3
14 Batten bracket	2		2	4	
15 Combi batten bracket		2	2		2
16 Gutter fixing strip		1	1		1
17 Side fixing tab	4		4	8	
18 Nail	4	1	5	8	1
19 4 x 25mm screw	4	4	8	8	4
20 4 x 50mm screw	12	12	12	12	12

ELECTRICAL

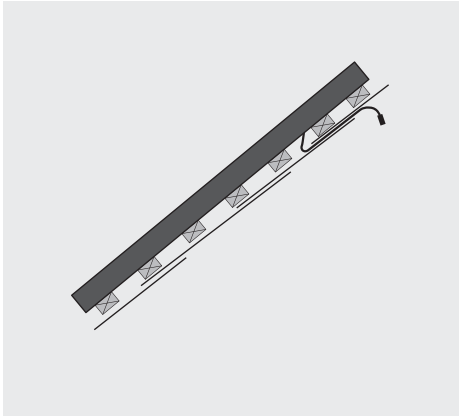

- Electrically test each solar panel as it is installed.
- Cables can be passed through roofing membrane laps for connection inside the building (recommended) or connected to adjacent panels in the batten space.

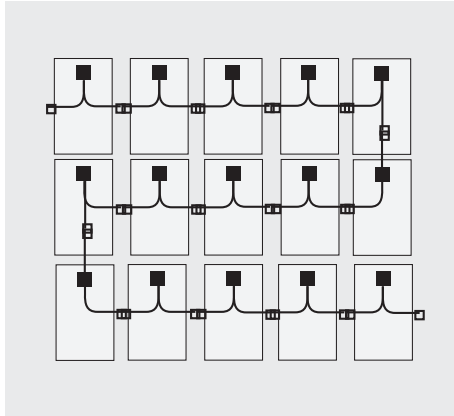

- Choose to connect panels in rows or columns based on consideration of shading and potential difference.
- Panels can be installed with the junction box at the top or bottom.
- **Important: Use only genuine Staubli MC4 when connecting to modules**

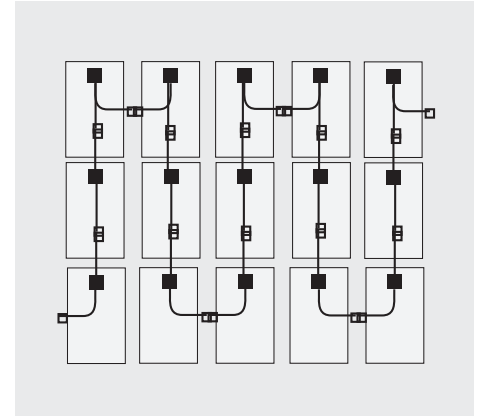

Arcbox

Making solar even safer

FIXING GUIDANCE

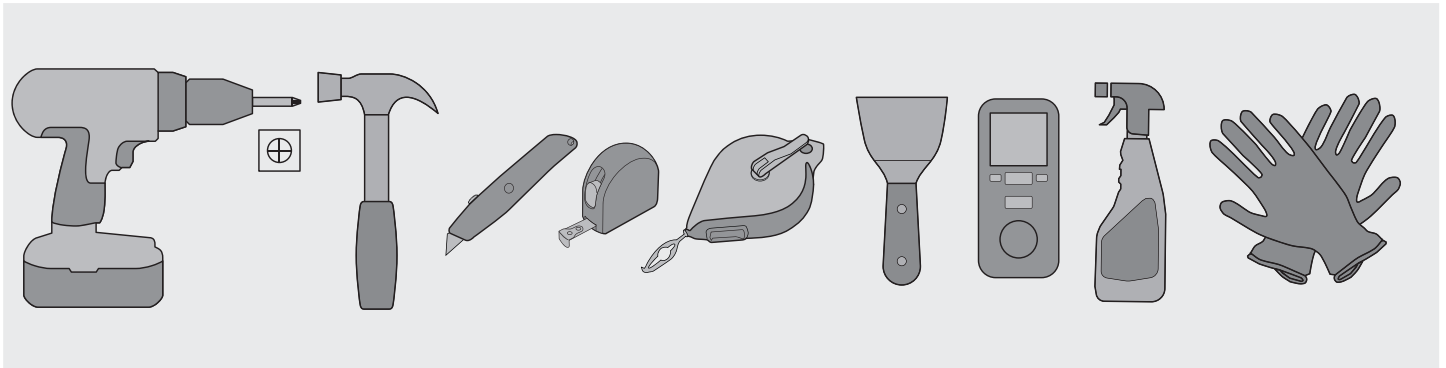

Important:

- Flashings may have sharp edges, wear gloves.
- The installation must comply with local regulations on lightning protection.
- Marley recommends that the panel installation is carried out by an installer with roofing competence.

For best results:

- Don't rush it.
- Ensure the flashing edges are straight.
- It may be helpful to lubricate gaskets before pushing in the flashing – use glass cleaner for this.

INSTALLATION OVERVIEW

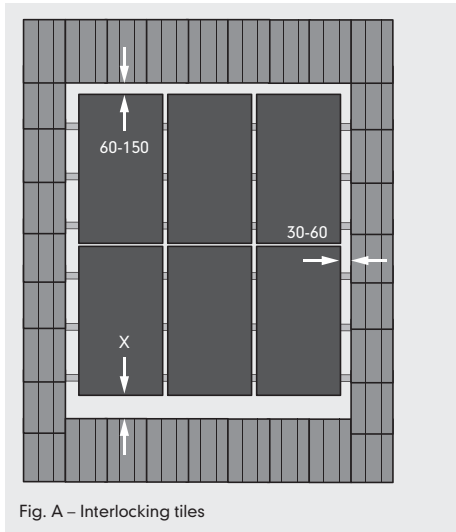

A Interlocking tiles – set lower gap ‘X’ 130-150mm above the head of the tile.

B Slate – for best results align the bottom edge of panel with the slate line. This may require that slates below the panels are nailed in advance. If installing before slating, set ‘Y’ to 130mm.

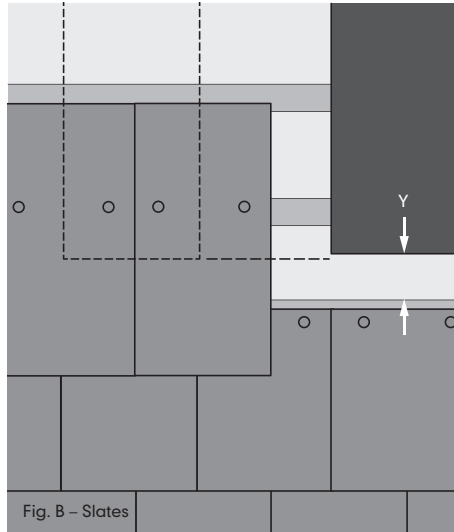

C Start at the bottom left of the array. Move to the right as each column is finished.

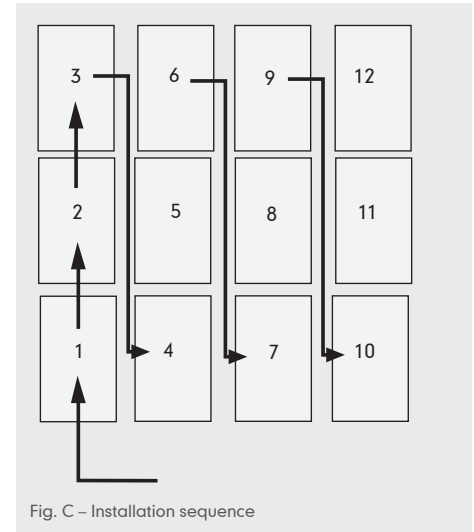

Important:
Marley SolarTile® is intended for installation above a continuous, functional underfelt that terminates in a gutter.

TILE BATTENS

Roofing kits are provided with brackets suitable for tile battens of 25mm thickness.

A For 22mm tile battens replace Rafter Brackets (12) with brackets from B22 kit. Replace Combi Rafter Brackets (13) with brackets from B22J kit.

B For tile battens of greater than 25mm thickness, use the required number of 5mm bracket spacers. Use SP-5 for Rafter Bracket (12) and SP-5J for Combi Rafter Bracket (13).

C For roofing without tile battens (direct fix to deck) replace standard brackets with brackets from Sarking Bracket kits as shown, aligning brackets to screw through into rafters below where they cross panels.

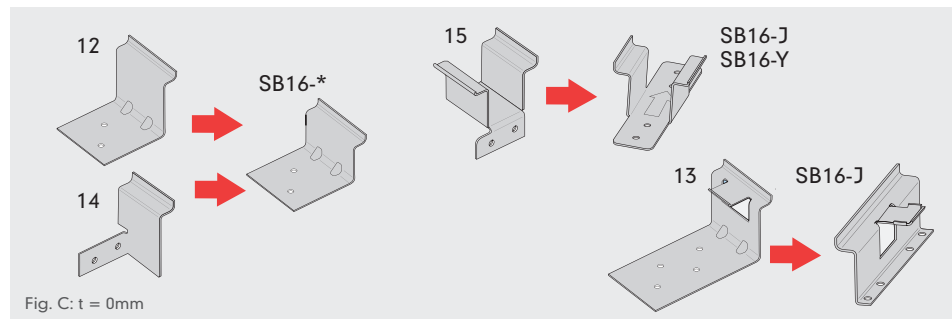
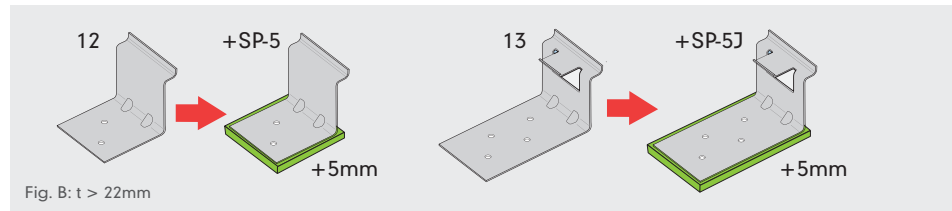
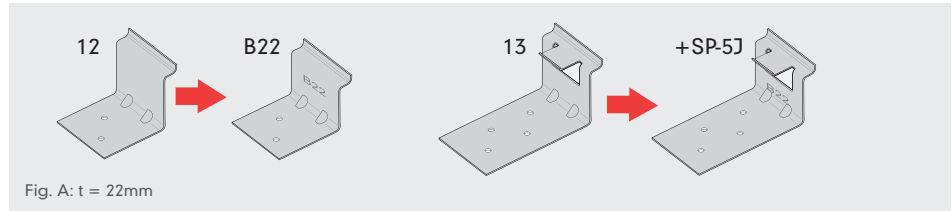
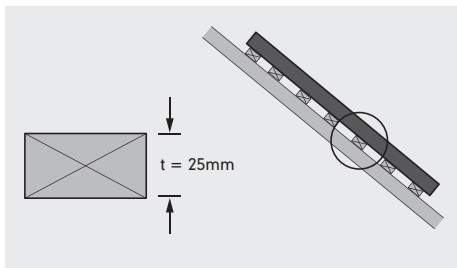

INSTALLATION SEQUENCE



The following portrait 3 above 3 installation illustrates how the system works for any rectangular array. Landscape installation follows the same principles.

OPEN THE YELLOW BOX

Start with the bottom left panel. Brackets rotate into the lower slot on the panel frame. Fix rafter brackets (12) at the bottom to each rafter the panel crosses with two 50mm screws (20) each. Fix the batten brackets (14) to the left side with two 25mm screws (19) each.

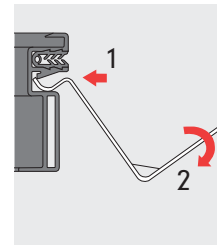
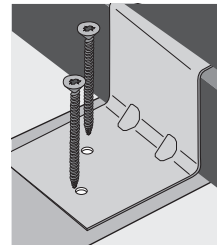
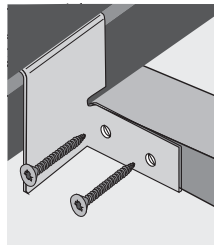
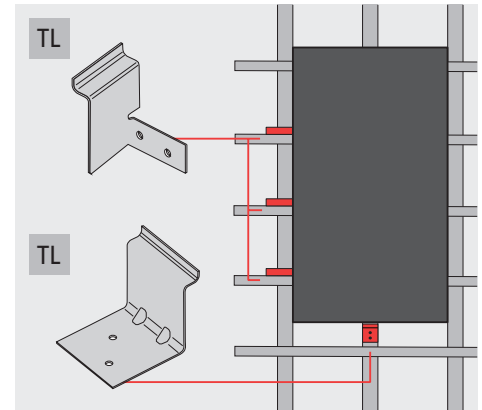
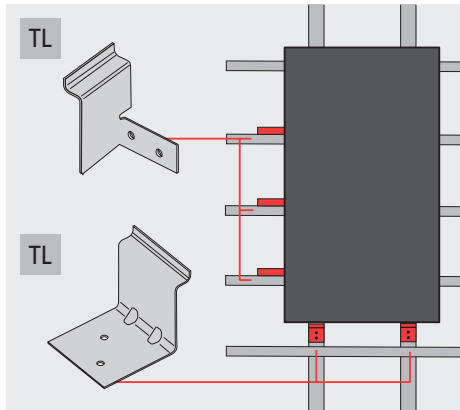

INSTALLATION SEQUENCE

2



Fit the sill flashing (A) then the lower side flashing (B) to the panel.

Flashings push into the rubber gasket seal in the upper slot of the panel frame. Take care to align the leading edge just above the yellow line on the gasket. If lubrication is required, use glass cleaning fluid.

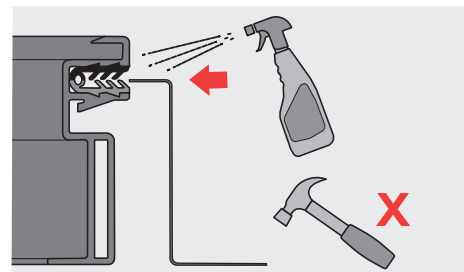
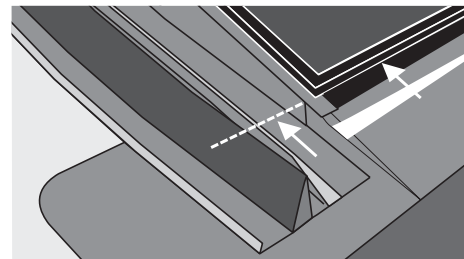
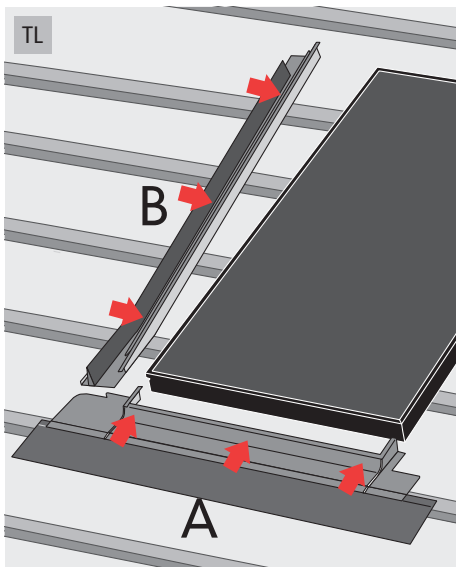

INSTALLATION SEQUENCE

3



Secure the edge of the side flashing using side fixing tabs (17) and nail (18). Fold over the tab on the sill flashing (a) to grip the side flashing. Fold down the tab on the side flashing (b).

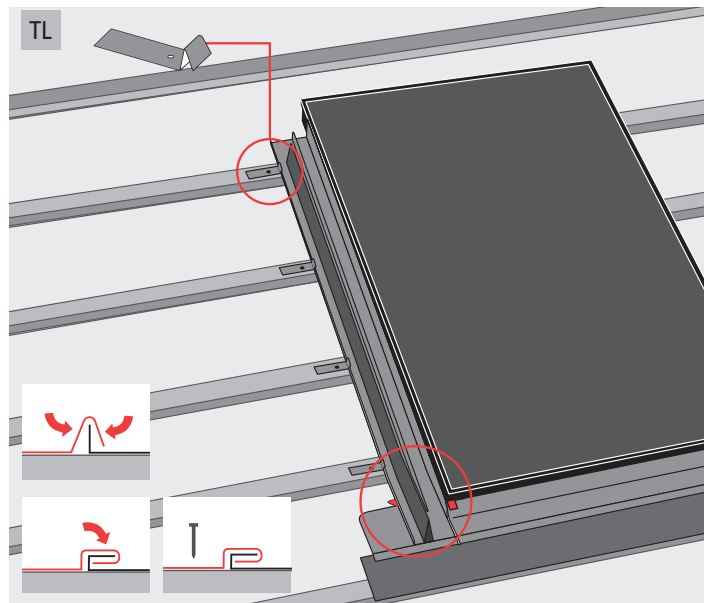
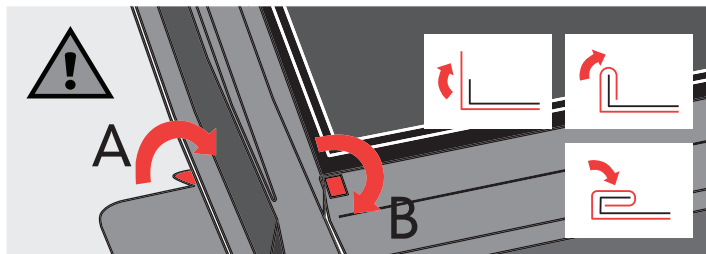

INSTALLATION SEQUENCE

4



OPEN THE GREEN BOX

Fix combi rafter brackets (13) to each rafter the panel crosses with four 50mm screws (20) each.

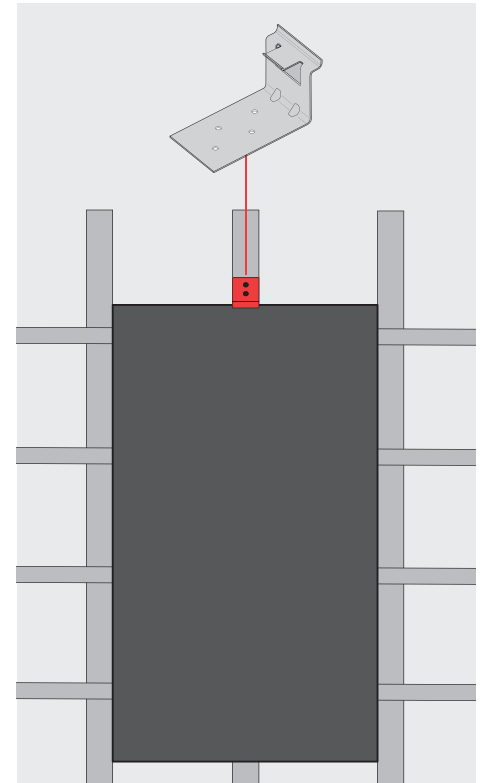
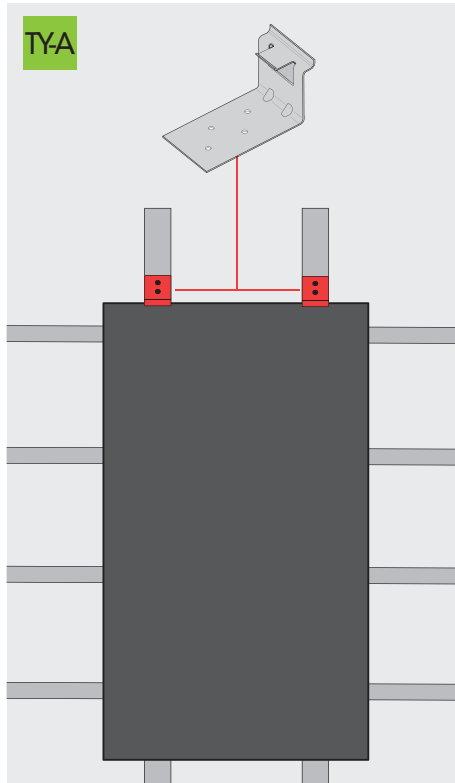
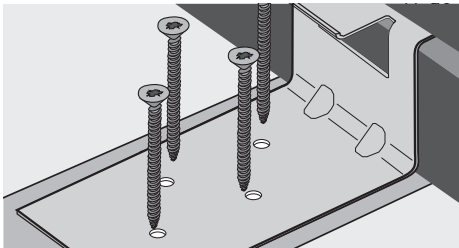
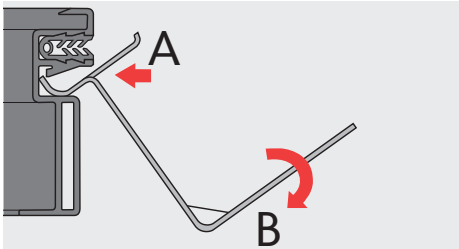

INSTALLATION SEQUENCE

5



Push the joining strip (6) into the gasket on the top face of the lower solar panel. Align to the centre of the panel.

Slide the upper solar panel down the roof to simultaneously engage with the combi-bracket and the joining strip. Aligning the panels on the right corner then rotating the left corner downwards ensures a smooth connection.

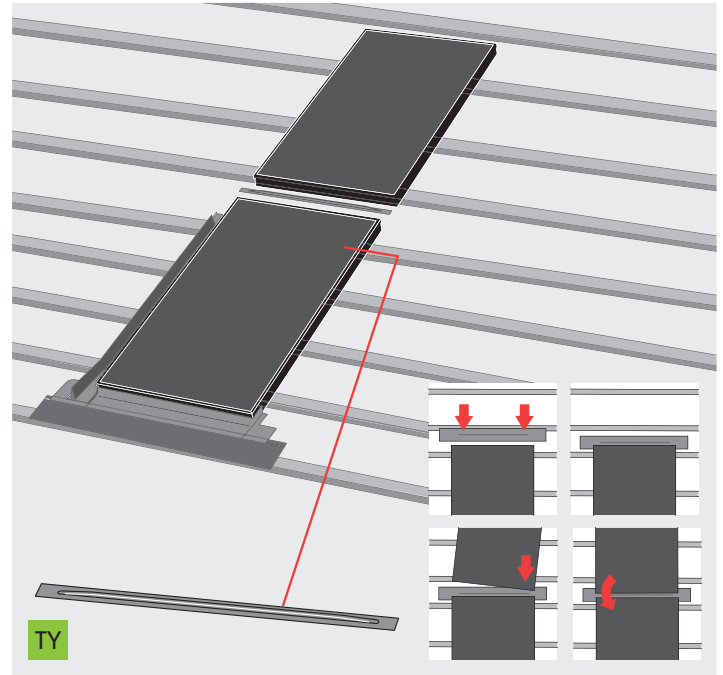
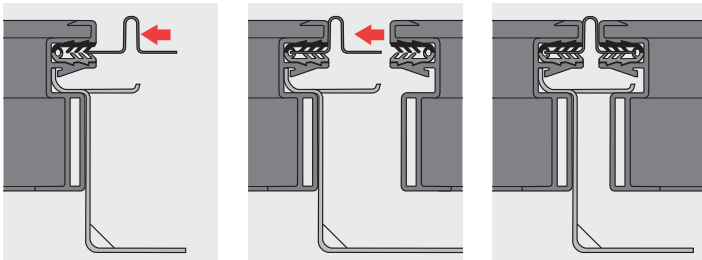

INSTALLATION SEQUENCE

6



Fix the left side of the solar panel with batten brackets (14) and 25mm screws (19). Push in the upper side flashing (4) and fix the outside edge with side fixing tabs (17).

Fold the protruding end of the joining strip (6) down over the side flashing.

Important: Do not fold the protruding end of the joining strip upwards

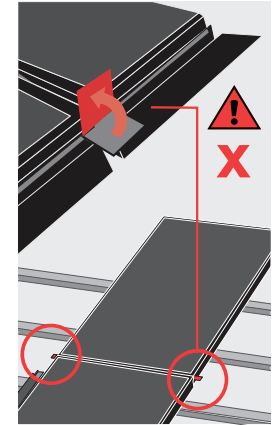
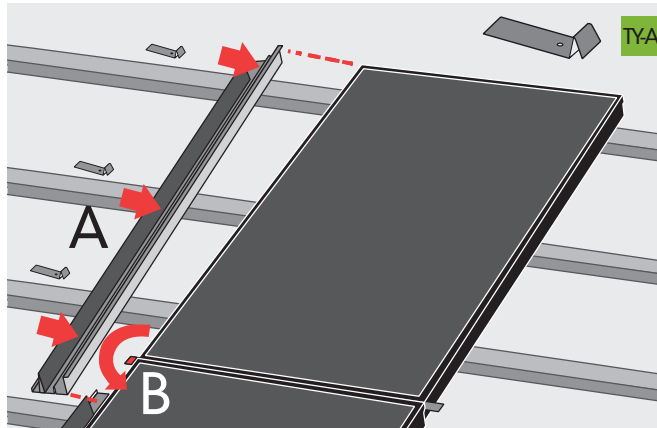
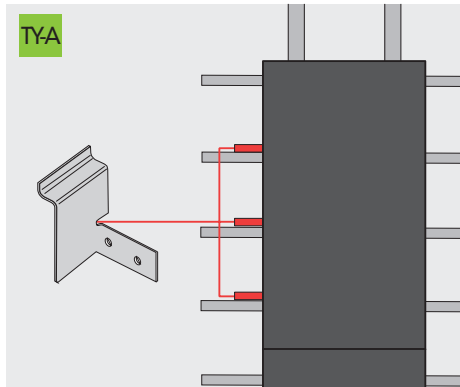

INSTALLATION SEQUENCE

7



RED BOX

Fix combi-batten brackets (15) to the right hand side of the bottom solar panel. The bracket must be turned so that the side with the taller edge goes into the panel. Fix each bracket with two 25mm screws (19).

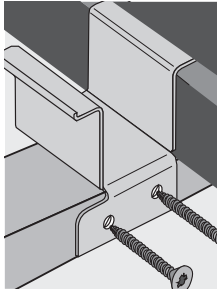
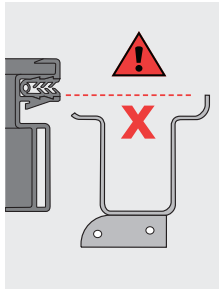
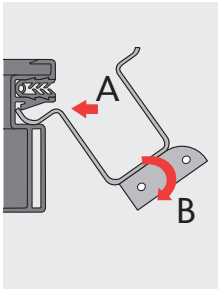

J

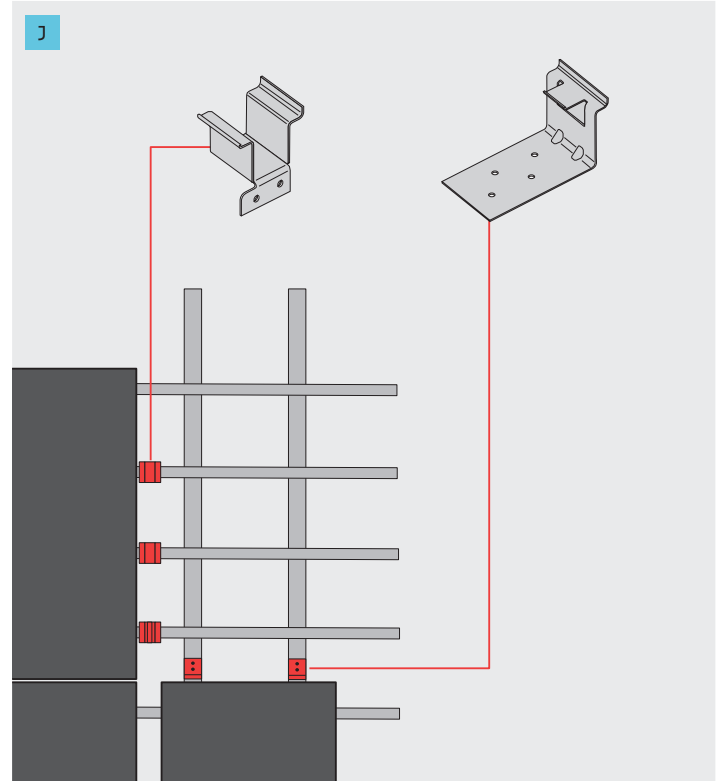

INSTALLATION SEQUENCE

8



Slide the first panel of the next column sideways to engage with the combi-batten brackets. The bracket sets the gap to 30 mm. Secure the new solar panel to each rafter it crosses with rafter brackets (12) and two 50mm screws (20) each.

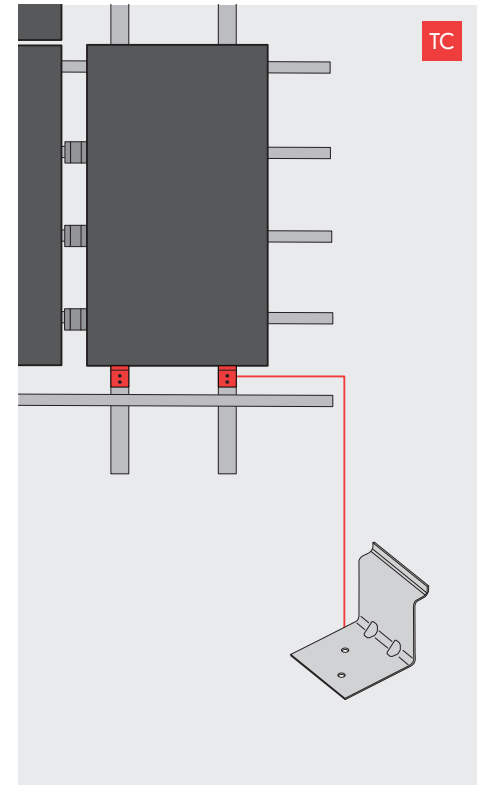
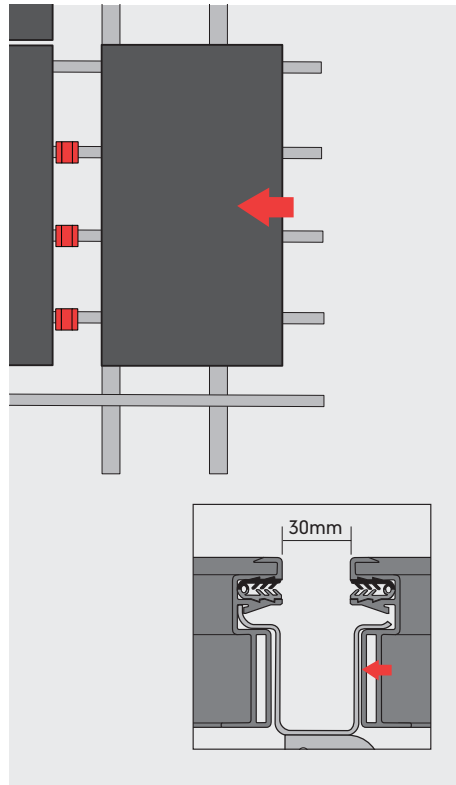

INSTALLATION SEQUENCE

9



Push the sill flashing (2) into the gasket on the solar panel.

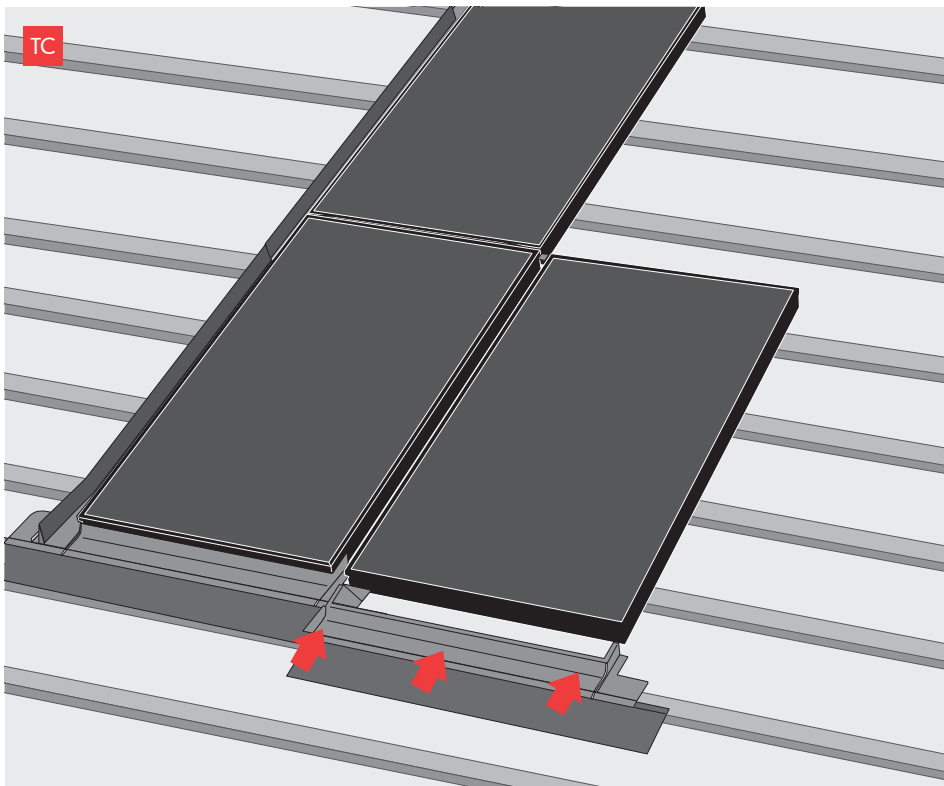

INSTALLATION SEQUENCE

10



Slide the lower gutter (7) between the two solar panels from the top. Fold the tab at the bottom behind the sill flashing. Loop the gutter fixing strip (16) into the slot on top of the gutter. Fix the strip to a batten with a nail.

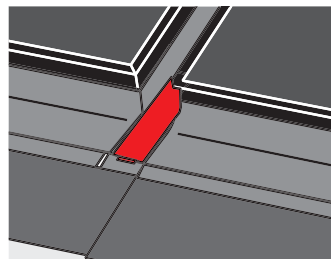
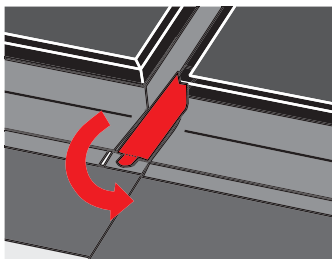
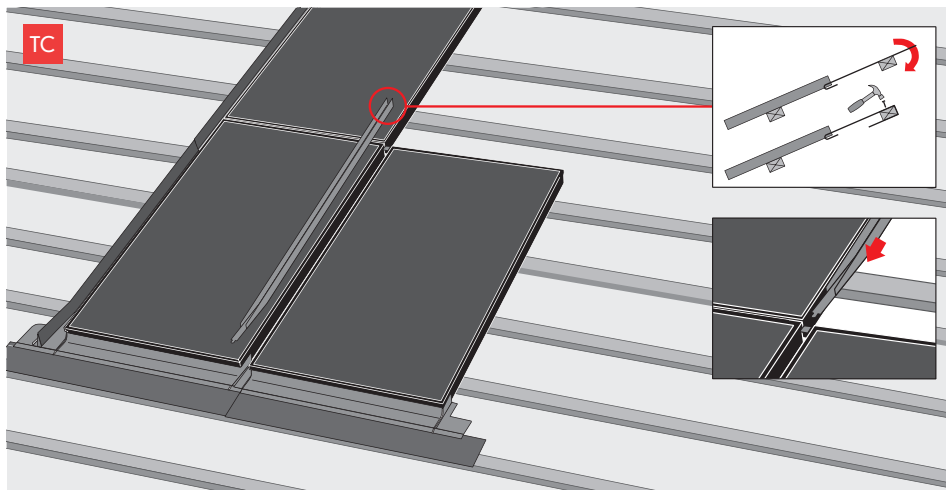

INSTALLATION SEQUENCE

11



Align the bottom corner of the lower gutter covers (8) with the bottom edge of the solar panel and push the gutter covers into the gasket. Fold down the retaining tabs.

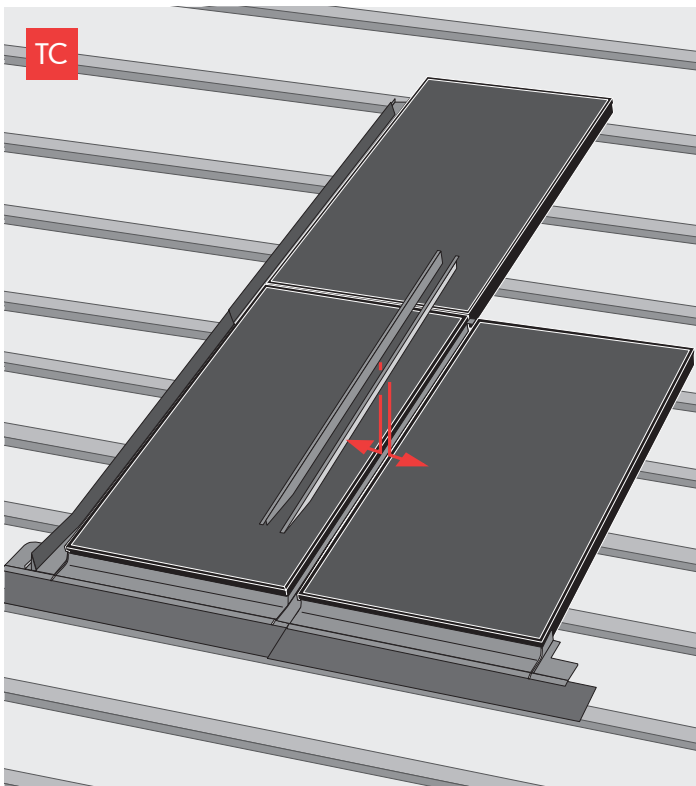
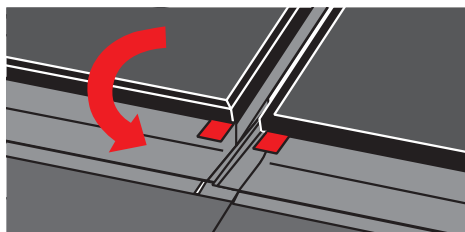
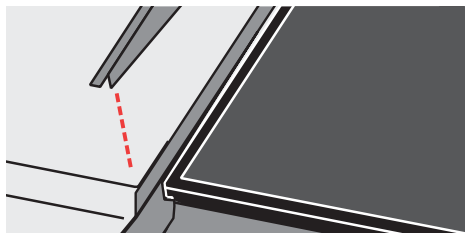

TIP: Installing the combi-batten brackets and the upper gutter before the lower gutter covers, can make this part of the installation quicker and more straightforward.

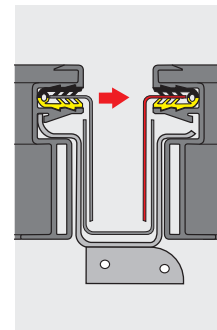
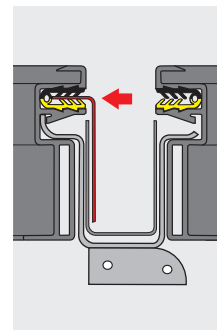

INSTALLATION SEQUENCE

12



BLUE BOX

Fix combi-rafter brackets (13) to the top of the panel below and combi-batten brackets (15) to the right hand side of the panel to the left.

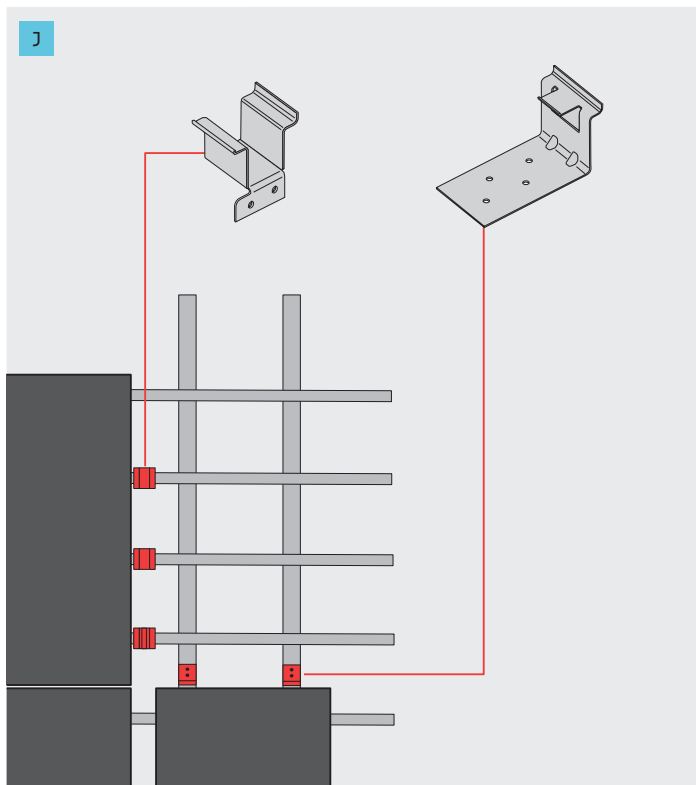

INSTALLATION SEQUENCE

13



Fit the upper gutter (9) between the solar panels and nail the gutter fixing strip to a batten. Push the upper gutter cover (10) into the panel gasket. Fold the end of the joining strip down into the gutter.

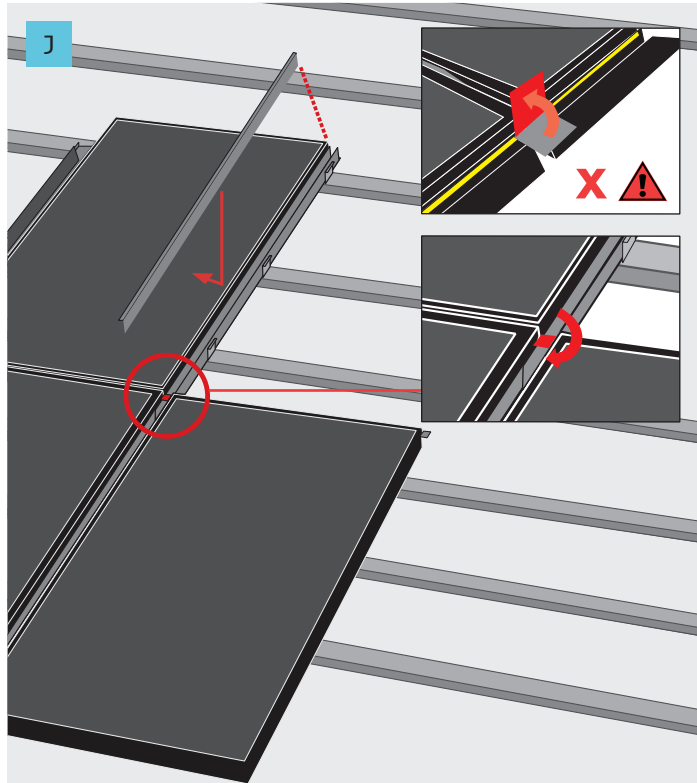
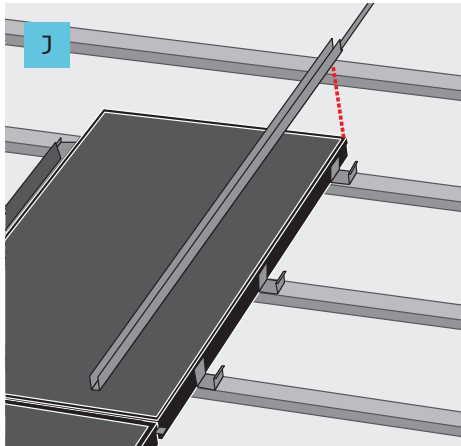

TIP: Installing the combi-batten brackets and the upper gutter before the lower gutter covers, can make this part of the installation quicker and more straightforward.

INSTALLATION SEQUENCE

14



For each rafter it crosses, fix a rafter bracket (12) to the top of the top left panel and secure with two 50mm screws (20) each. You may need to add a batten above the panel to support the top flashing. Push the top flashing (5) into the panel gasket. The tile support (11) is needed for some tile types. Feed the two straps under the foam and secure the straps to a batten above.

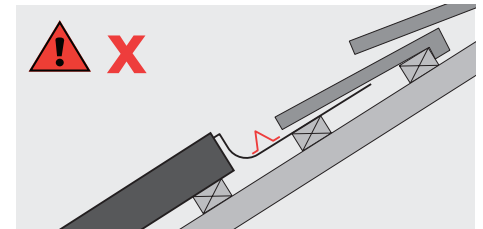
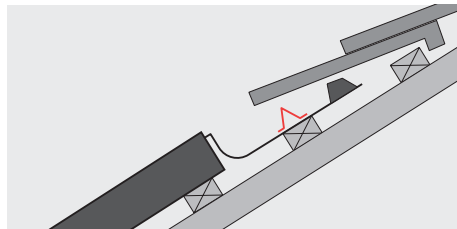
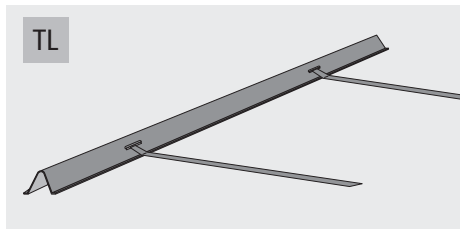
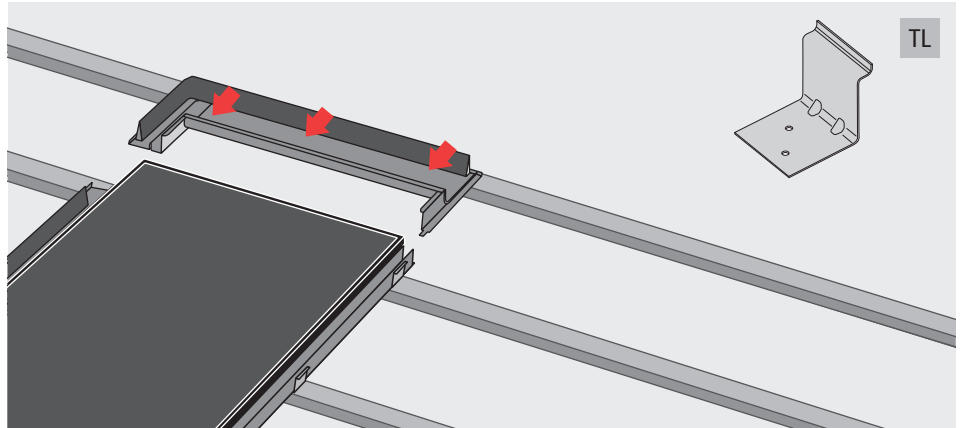

INSTALLATION SEQUENCE

15



Push the joining strip (6) into the gasket in the top edge of the panel below and slide the solar panel in to engage with the joining strip and combi-brackets on two sides.

Fit gutter cover (10) into the panel gasket. Fold the end of the joining strip down into the gutter.

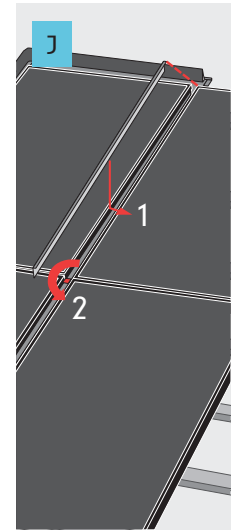
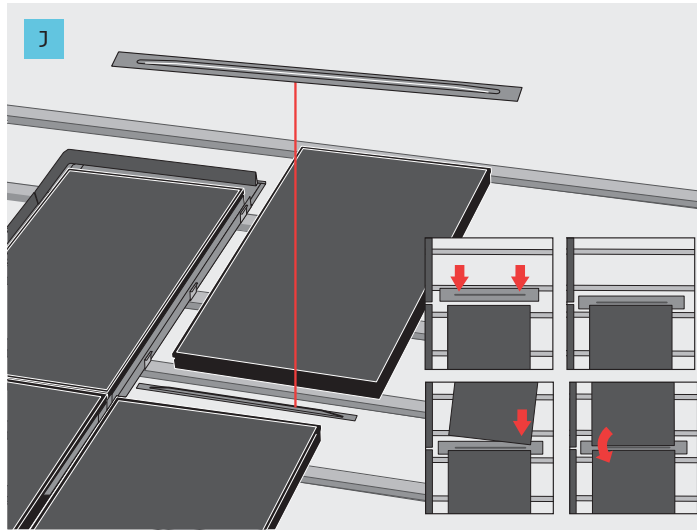

INSTALLATION SEQUENCE

16



ORANGE BOX

Fix three combi-batten brackets (15) to the right hand side of the panel to the left. Slide the new panel into position. Fix with rafter brackets (12) on the bottom edge and batten brackets (14) to the right hand side.

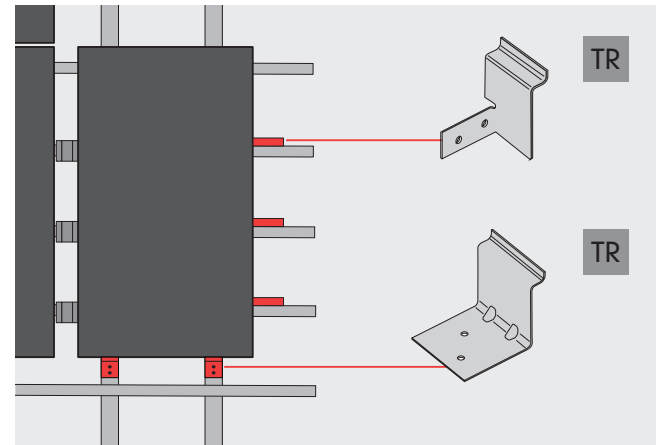
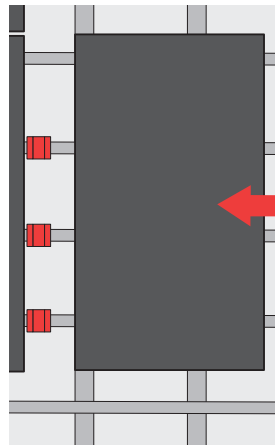
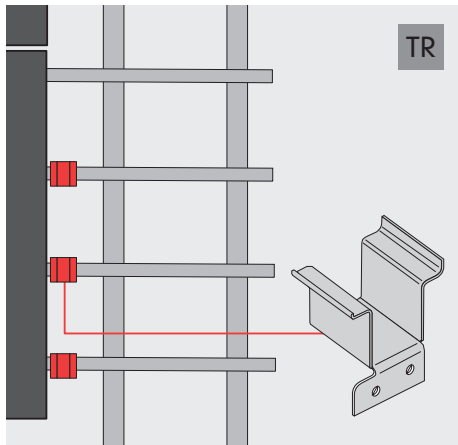

INSTALLATION SEQUENCE

17



Fit the lower gutter (7), (16) and lower gutter covers (8). See steps 10 and 11.

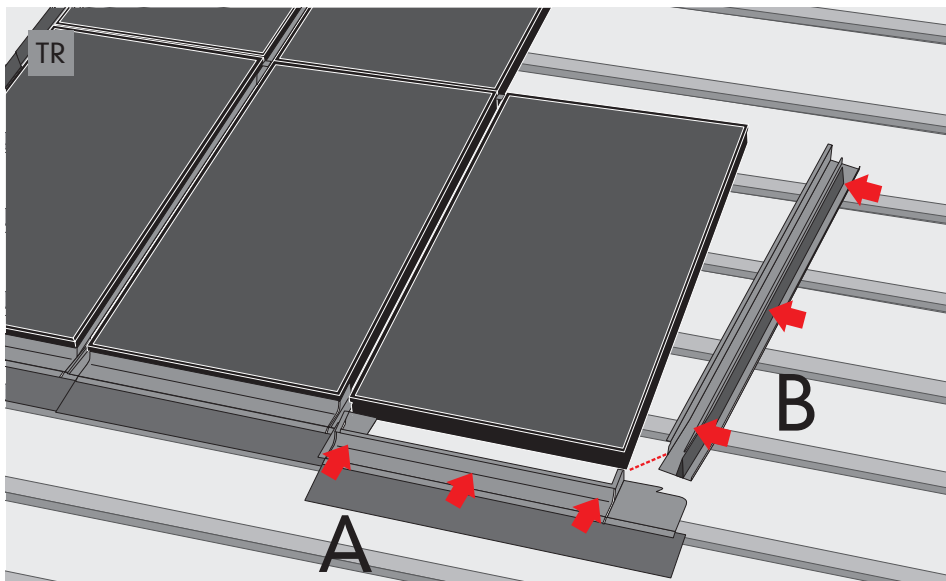

INSTALLATION SEQUENCE

18



Fit side fixing tabs (17) and fold over the tab on the sill flashing. See step 3.

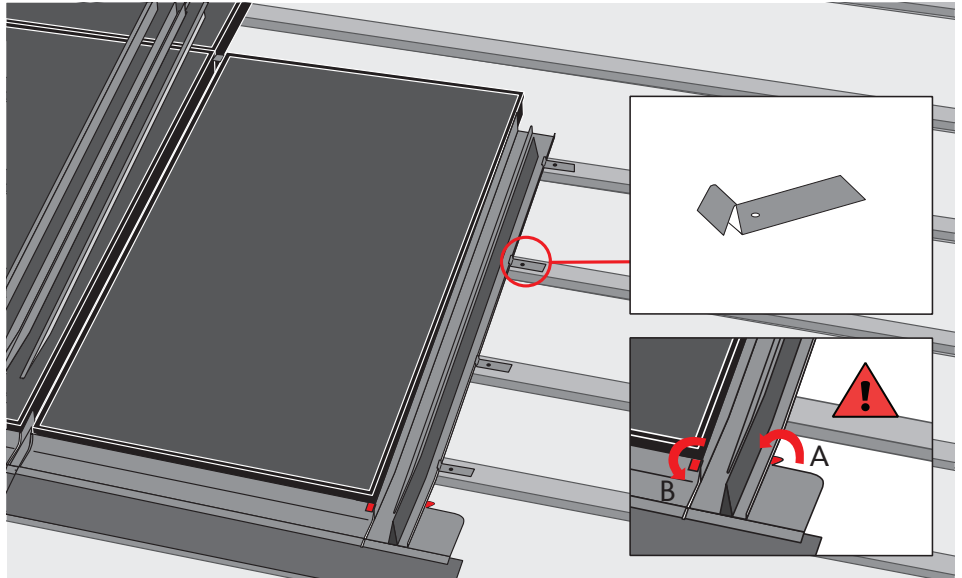

INSTALLATION SEQUENCE

19



BLUE BOX

Repeat steps 12 to 15 with TC kit and J kit.

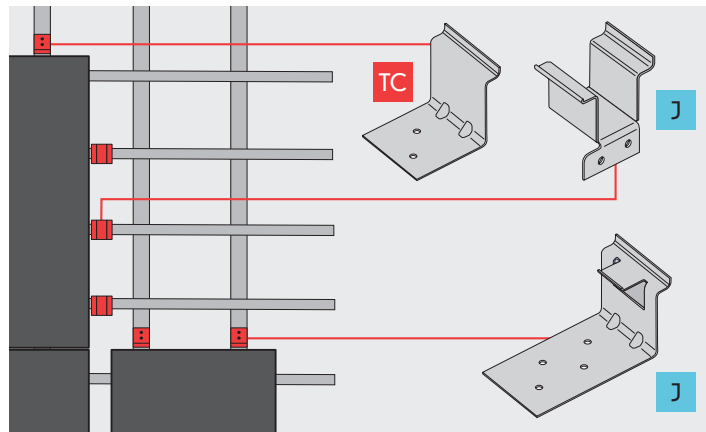
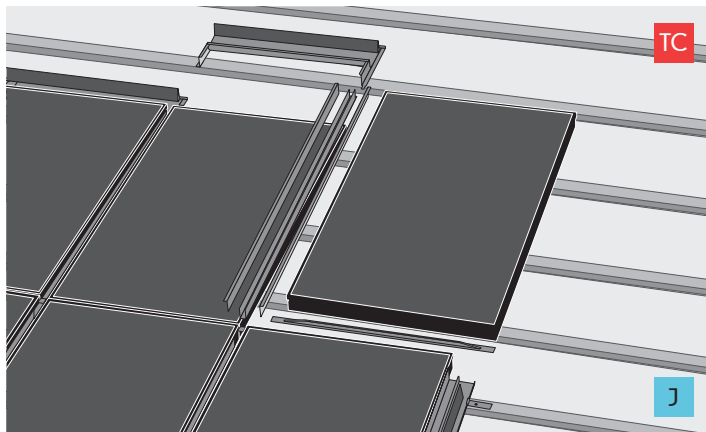

INSTALLATION SEQUENCE

20 

Repeat step 6 to fit batten brackets and upper side flashing

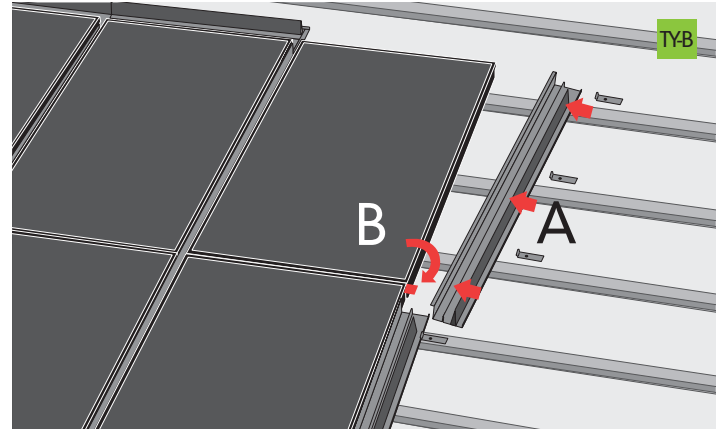
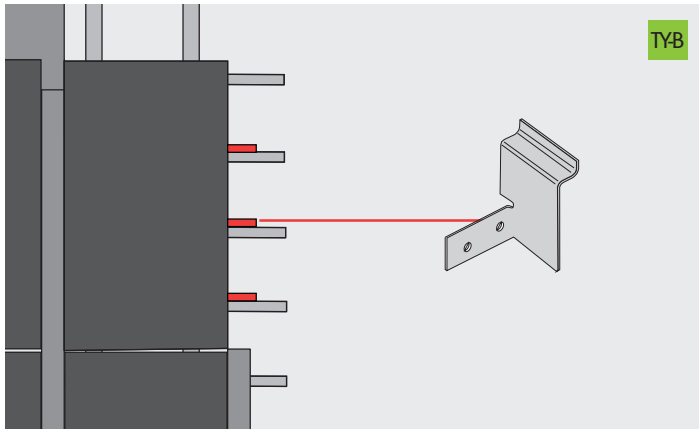

INSTALLATION SEQUENCE

21



Repeat step 14 with TR kit.

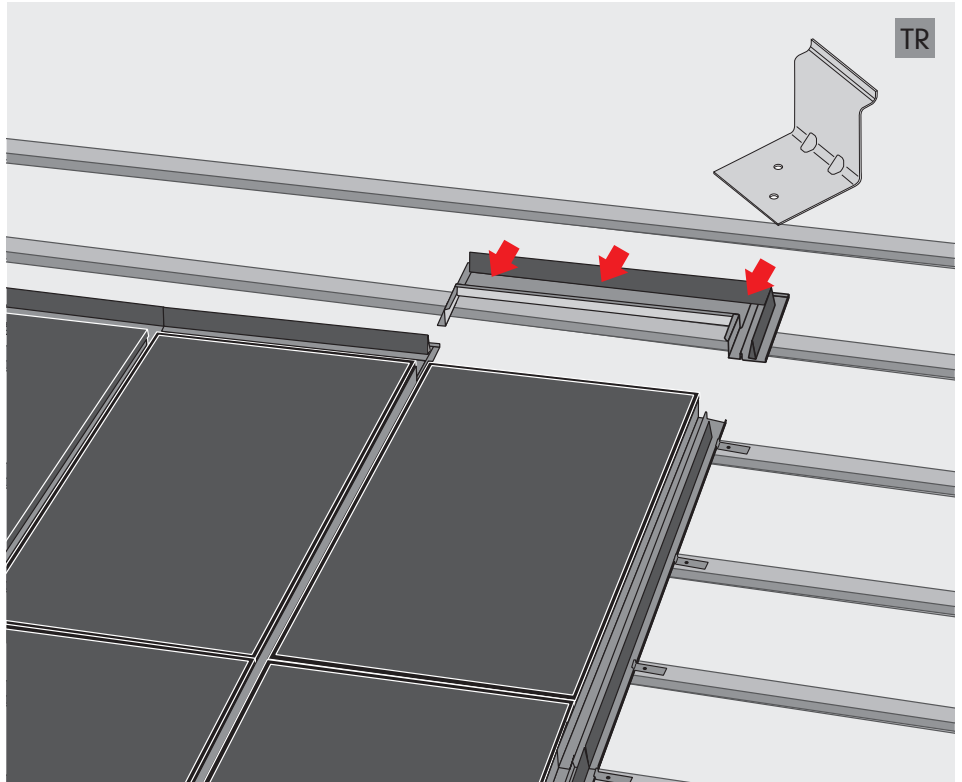

INSTALLATION SEQUENCE

22



Remove the paper strip on the underside of the sill flashing and press down onto the tiles. **Ensure that the bitumen strip is well-bonded to the tiles. In some circumstances, for example a dusty tile surface, the application of a low modulus external silicone sealant will be required to achieve good adhesion.**

For some tile types it may be necessary to chamfer the high points under the sill flashing. Lighter tiles will sit more neatly if the foam surround is trimmed. For slates, trim the foam to within 10mm of its base and flatten over the outside edge of the flashing.

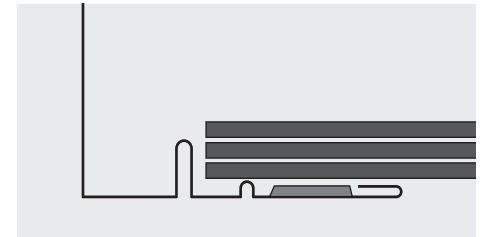
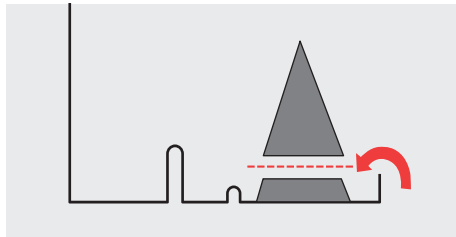
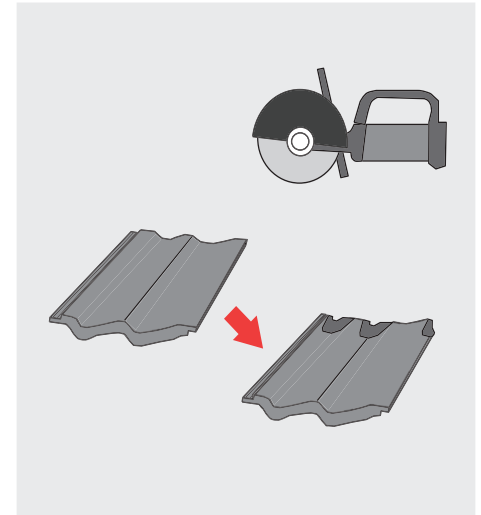
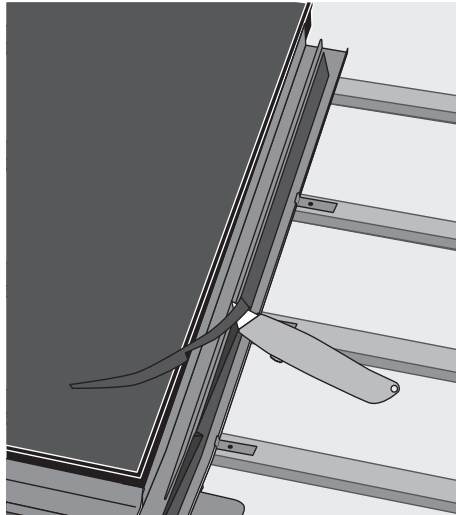

Corner installation

For corner installations, please download the SolarTile Installation guide from marley.co.uk/solar-roof-tiles/solartile



CONCRETE AND CLAY PLAIN TILES

82 Setting out the roof

85 Eaves

86 Verges

87 Hips

89 Valleys

91 Vertical tiling

 Dry fix and ventilation systems
For more details, 131-244

SETTING OUT THE ROOF

It is important that the tiler sets out the roof for the battens prior to fixing, to ensure the eaves and top edge positions are correct and that the battens are fixed at an even gauge which does not exceed the maximum. Setting out across the roof is important to identify any 'out-of-square' in the roof, to avoid unnecessary cutting, and to keep the tiling straight horizontally and vertically (Fig. 1).

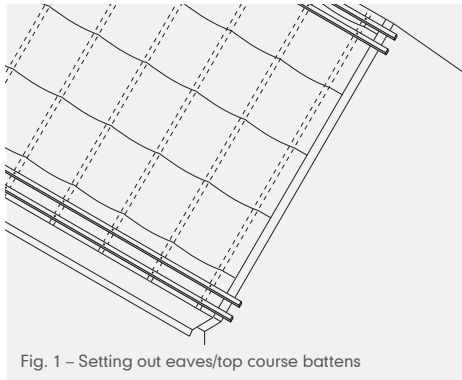

Fig. 1 – Setting out eaves/top course battens

POSITION OF TOP AND BOTTOM BATTENS

- 1 Fix eaves course batten first and position using the following method:

Battens at the eaves should be positioned so that the tiles provide effective drainage into the gutter and extend over the fascia board by no less than 50mm on the rake (Fig. 2).

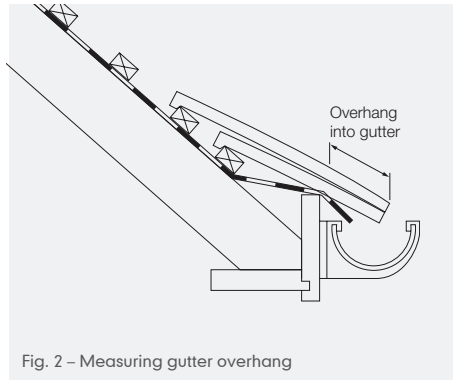

Fig. 2 – Measuring gutter overhang

To do this, measure from the underside of the tile nib to the tail of the tile to establish the hanging length, then extend your tape 50mm over the fascia board and mark off the position of the batten.

- 2 When using plain tiles, position an additional eaves batten below the first full tile batten so that the tails of the two tiles align.

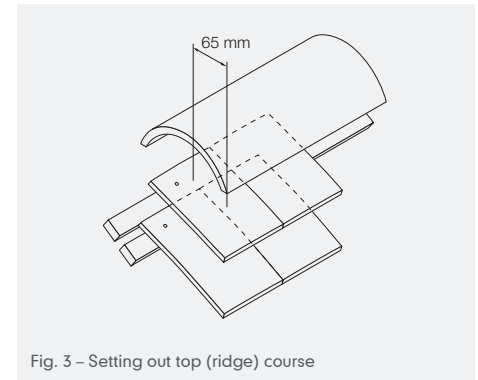

Fig. 3 – Setting out top (ridge) course

SETTING OUT THE ROOF

CALCULATING THE BATTEN GAUGE

- 1 Install battens at 100mm gauge to within 15-20 courses of the ridge/top edge.
- 2 Mark the position of the top course batten (to allow enough room for the tile nibs (normally), the eaves/tops batten, and eaves/top course) and, if necessary, reduce the gauge of the remaining 15 -20 courses evenly in 5mm increments or less.
- 3 Round figure up to give number of courses up slope as a whole number.
- 4 Divide measured distance by number of courses to give batten gauge.
- 5 The practice of adjusting gauge over last few courses at eaves or ridge is technically acceptable, provided maximum gauge for tile is not exceeded.
- 6 If necessary, tiles should only be cut in ridge course, drilled and nailed.
- 7 Re-check the accuracy of the lap by measuring the exposed margin, which is equal to the gauge required (see above).

HORIZONTAL ALIGNMENT

The most effective way to achieve horizontal alignment is to mark the position of the battens onto the underlay at each end of the roof and strike chalk lines between the points (Fig 4.) Large roofs may need one or more intermediate marking points.

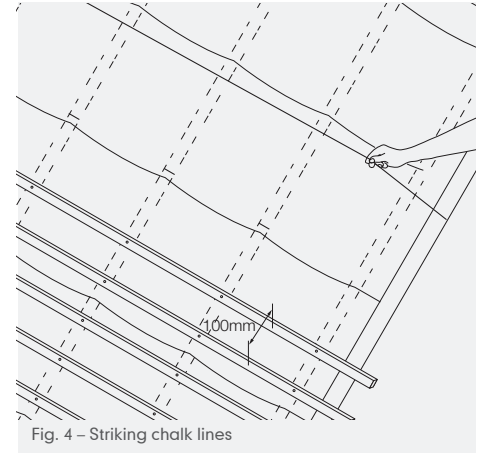

SETTING OUT THE ROOF

PERPENDICULAR ALIGNMENT

- 1 Set out roof along eaves starting with correct overhang at right-hand verge.
- 2 Plain tiles can be installed with gaps up to 3mm per tile
- 3 Overhang at verges should not be more than 50mm.
- 4 Tiles may require cutting to width to achieve the desired overhang at the verges. Where this is necessary, leave the verge tiles and tile-and-a-half tiles whole, and cut the adjacent tile/s, ensuring that the minimum side lap of 55mm is maintained.
- 5 Strike perpendicular chalk or ochre lines over eaves to ridge at five or six tile intervals to coincide with edges of tiles.
- 6 A gauge rod/marketing batten the width of five or six tiles can be used as an alternative to actual tiles.

COMPLETION OF TILING

- 1 Load out all tiles on the roof evenly before commencing tiling (see page 11).
- 2 Plain tiles can be laid right to left (Fig 5) or left to right. Depending on the fixing specification, tiles can be left out to expose the battens for safe working, and filled in later when details at the ridge, hip, valley etc. have been completed.
- 3 On a hipped roof, cut tile-and-a-half tiles so that end tiles of each course align with rake of hip.

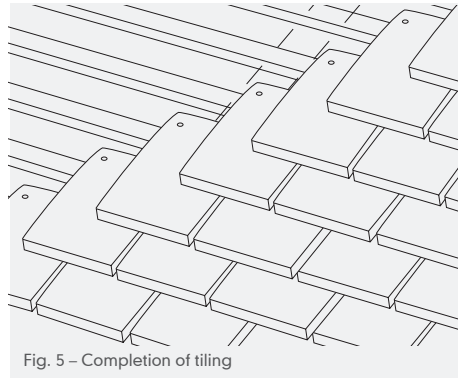

Fig. 5 - Completion of tiling

Setting out check points

- Never exceed maximum gauge for tile used at recommended pitch.
- Avoid cutting tiles wherever possible and never cut bottom edge of a tile.
- Plain tiles should never be cut less than 110mm wide to provide a minimum side lap of 55mm. Tile-and-a-half tiles should be used to avoid small cuts
- Ensure ridge tiles provide a minimum 65mm cover to top course of full length tiles.
- The double course of tiles at the eaves should extend over the fascia board by no less than 50mm on the rake.

EAVES

Eaves have a double course throughout their length using purpose-made eaves tiles for the undercourse.

- 1 Twice nail both courses.
- 2 Eaves course to overhang fascia board so that water discharges into centre of the gutter.
- 3 There should be an overhang of 50mm on the rake (Fig. 6).
- 4 A sprocketed eaves detail may be used, provided it is not below the minimum roof pitch for the tile.

See page 249 for Eaves fascia heights without ventilation.

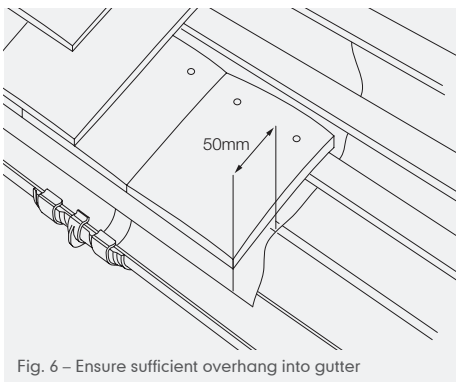

Fig. 6 – Ensure sufficient overhang into gutter

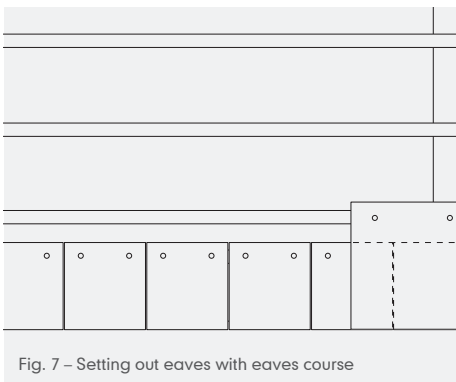

Fig. 7 – Setting out eaves with eaves course

Eaves check points

- Twice nail all eaves tiles.
- Supply support for under-eaves course and eaves course tiles using tilting fillet or fascia board.
- Make allowance for strip ventilators fitted to the top of the fascia when calculating the pitch of the eaves course (see page 132).
- Ensure bottom courses overhang into gutter 50mm.

VERGES

- 1 A plain tile undercloak can be used in place of a fibre cement strip.
- 2 Lay face down with tail edge facing outwards (Fig. 8).

Note: Do not use Plain tiles as an undercloak below 30° pitch.

- 3 Lay verges broken/half ond with full tiles and tile-and-a-half in alternate courses.
- 4 Bed tiles projecting 38-50mm over the gable walls or bargeboard.
- 5 Strike off bedding mortar and neatly point in one operation.
- 6 Alternatively, bed tiles in mortar onto a fibre cement undercloak.
- 7 When laid on brickwork or masonry, bed undercloak in mortar and strike off flush with external face of wall, leaving top surface finished smooth and straight; bed tiles forming verge on this undercloak.
- 8 When laid on boarding, nail each undercloak at centres of not more than 300mm.

For plain tile cloak verge tiles, see page 166.

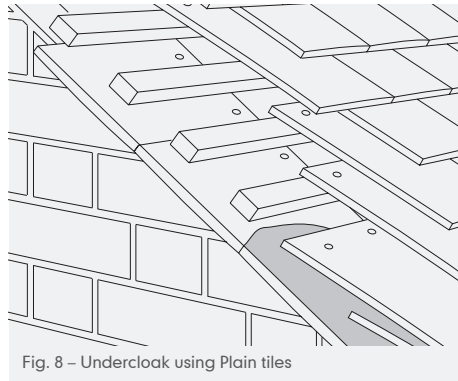

Fig. 8 – Undercloak using Plain tiles

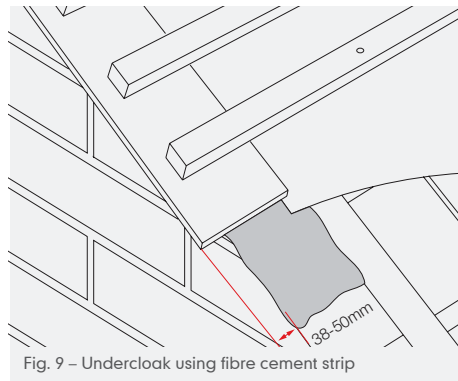

Fig. 9 – Undercloak using fibre cement strip

Verge check points

- All verge tiles must be twice nailed.
- Always continue underlay across wall cavity and below undercloak (where appropriate).
- Cut batten ends should be treated with a suitable timber preservative.
- Mortared verges should have an overhang of 38 to 50mm.
- Undercloak should have an outward tilt on mortared verges.
- Avoid pointing with a separate mix of mortar.

HIPS

THIRD ROUND HIP TILES

- 1 Fix a galvanised hip iron at foot of hip as support (Fig. 10).
- 2 Edge-bed third round hip tiles onto tiles cut closely to the centre of the hip to provide sufficient cover onto the tiles with a solid bedding at butt joints.
- 3 Fix a raking batten to the hip rafter to provide a continuous fixing point for the bonnets, to aid alignment and avoid excessive mortar depth.

BONNET HIP TILES*

- 1 Fix supplementary batten to hip tree where required to ensure alignment of bonnet hip tiles and avoid excessive mortar depth.
- 2 At eaves, solidly bed bonnet hip and fill with dentil or tile slips where possible.
- 3 Bed in mortar during fixing. Strike bedding off smoothly at lower edges of hip tiles or keep slightly back and point to leave clean edges. Re-point any displaced mortar resulting from nailing.
- 4 Cut tiles or tile-and-a-half to sides of bonnets to maintain minimum side laps and return the tiling to half-bond, and fix bonnets with aluminium nails to penetrate the raking batten or the hip rafter by no less than 15mm (Fig. 11).
- 5 Use tile-and-a-half tiles where necessary, to facilitate cutting adjacent to bonnet hip tiles.

* Can only be used on hips with an equal pitch either side.

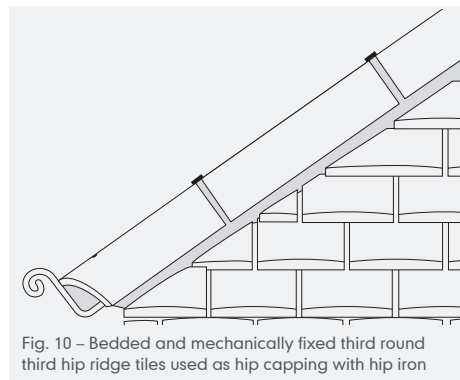

Fig. 10 – Bedded and mechanically fixed third round hip ridge tiles used as hip capping with hip iron

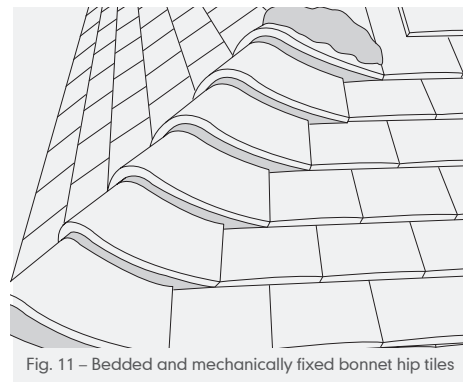

Fig. 11 – Bedded and mechanically fixed bonnet hip tiles

HIPS

CLOSE-FITTING ARRIS HIP AND PURPOSE-MADE HIP TILES

- 1 Lay and fix bottom hip tile in line with under eaves course.
- 2 Fix close fitting hip tiles with aluminium nails penetrating at least 15mm into the hip rafter or supplementary hip batten.
- 3 Bed head of hip tiles to provide seating in mortar.

MITRED HIPS*

- 1 Cut tile-and-a-half tiles to a close rake to hip line.
- 2 Cut Code 3 lead, fish-tail soakers, to extend a min. 100mm either side of hip and with the top 25mm folded over the head of the tiles.

* Recommended minimum pitch Change 30° to 45°.



Hip check points

- For bedded third round hip tiles, fix a suitable hip iron to the base of rafter.
- Cut bottom hip tile to align with eaves.
- Cut tiles to centre of hip and ensure each tile is twice nailed.
- Avoid small cuts by using tile-and-a-half tiles.
- At the ridge junction (i.e., three-way mitre), use a steeper ridge tile where available to ensure the hip and ridge tiles meet at the correct height.
- Mitred hips should not be attempted where the roof pitch either side of the hip differs by more than 5° or where roof pitches are less than 45°.

VALLEYS

VALLEY TILES*

Valleys with plain tiles may be formed with purpose-made valley tiles or open construction, using metal lined valleys or pre-formed GRP valley liners.

Valley tiles cannot be used where two roof slopes intersect with different pitches.

- 1 For trussed rafter roofs, support tiling battens. For trussed roofs without valley board, support tiling battens on timber noggin at valley junction
- 2 Timber valley boards may be installed between rafters to provide support for tiling battens and valley tiles.
- 3 Lay a strip of underlay at least 600mm wide up the valley and overlap main underlay to the centre of the valley.

Lay valley tiles without nailing or bedding to main roof tiling (Fig. 12).

- 1 Mitre the under-eaves tiles to provide no less than the minimum side lap to the first valley tile.
- 2 Lay the first valley tile and cut tiles to fit both sides. Keep valley tiles to a true line with tails aligned with the main roof tiles.
- 3 Keep a true line between valley tiles and main roof tiles.
- 4 Avoid small cut pieces of tile adjacent to valley tile by using tile-and-a-half tiles.

* Can only be used on valleys with an equal pitch either side.

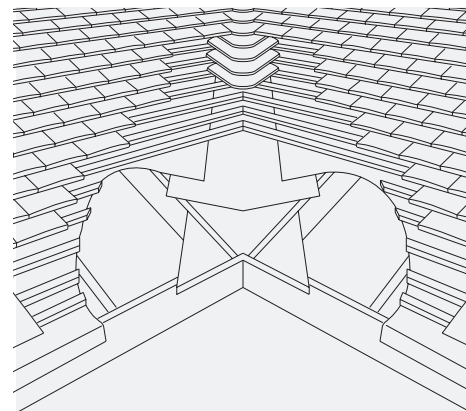

Fig. 12 – Laying valley tiles

VALLEYS

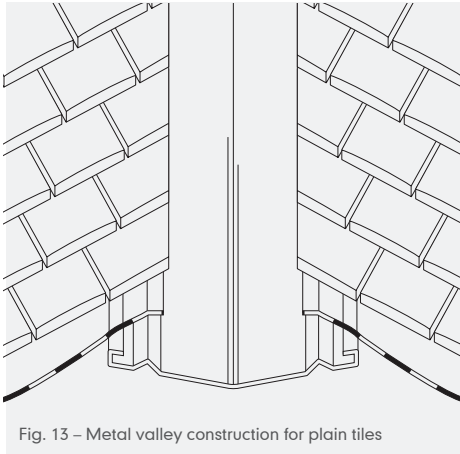

Fig. 13 – Metal valley construction for plain tiles

METAL VALLEYS

Metal valleys may also be used with plain tiles. Exposed raking cut tile-and-a-half tiles should be bedded onto a suitable undercloak and not block the laps. If concealed mortar is used within the tiling, it should not block the laps.

- 1 Use tile-and-a-half tiles to minimise use of small tile sections at valley.
- 2 Nail all tiles and cut pieces adjacent to valley (Fig. 13) as per the fixing specification.

VALLEY WEATHERINGS

- 1 At head of valley, fix a saddle of minimum Code 4 lead. Length of lap of saddle over valley should be at least 200mm.
- 2 Where ridge intersects a roof slope, step the ridge back where it meets head of intersecting valley; dress a saddle of minimum Code 4 lead under adjacent tiling, and over both valley linings.

Valley check points

- Keep an open channel between cut edges of roof tiles (125mm minimum).
- Don't block laps of tiles with mortar since this may cause damming.
- Roofing underlays should not be installed below metal lined valleys. For further guidance contact the LSTA*.
- Don't apply mortar direct to lead.
- Nail all tiles either side of valley.
- Valley tiles cannot be used where two roof slopes of different angles intersect.

*Lead Sheet Training Academy

VERTICAL TILING

Vertical plain tiles can be fixed to timber framed construction or masonry walls. Decorative pattern tiles are often incorporated into the design to provide an aesthetically pleasing finish.

UNDERLAY

A moisture barrier, such as Marley Vapour Permeable Underlay should be provided for all vertical tiling applications, and brick and blockwork construction, an HR (high water vapour resistance) underlay is adequate. For timber framed wall application, an LR (low water vapour resistance) breather membrane with third party certification is recommended.

Underlay should be lapped 100mm horizontally and 100mm vertically, all joints should be staggered and secured by austenitic stainless steel staples or nails.

BATTENS

There should be battens and counter battens fixed to the wall structure and consideration should be given to the use

of proprietary fixings such as 'Rawlplug' or 'Hilti' type bolts/fixings for dense concrete and stone masonry walls.

- 1 Provide a moisture barrier for vertical applications. With brick and blockwork, roofing underlay is generally used.
- 2 Lap underlay 100mm horizontally and 150mm vertically and secure with clout nails.
- 3 Battens can be fixed directly to blockwork using air-driven masonry nails or fixed to counter battens.
- 4 On timber frame constructions, fix battens to a maximum gauge of 115mm and secure with wire nails to timber studding. Battens to be at least 1.2m in length, sufficient to be supported at each end and intermediately by at least three studs or walls.
- 5 Stagger butt joints over intermediate supports so that not more than three battens are joined in any twelve consecutive supports. Batten ends must be sawn.

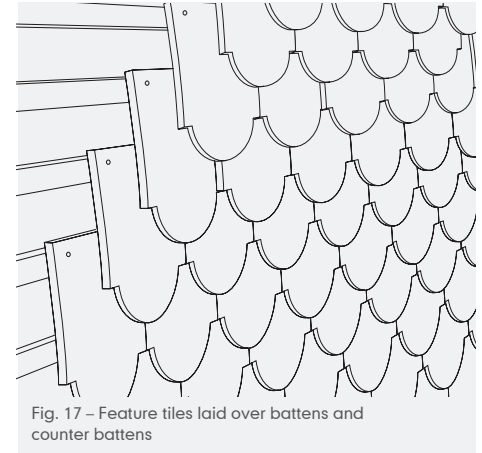

Fig. 17 – Feature tiles laid over battens and counter battens

Note: Dependent on design and property type, additional fire prevention may be required. Please contact Technical Advice on 02183 722330 for further information

VERTICAL TILING

FIXING

- 1 Lay vertical plain and feature tiles to a minimum lap of 35mm, maximum gauge 115mm.
- 2 Fix each tile with 2 No. 38mm x 2.65mm aluminium nails.

EAVES

- 1 Lay a double course of tiles at eaves. Form by laying a first course of eaves tiles with a course of full tiles laid half/broken bond on top.
- 2 Tilt eaves tile a minimum of 65mm from the face of the wall or the counter batten.
- 3 Twice nail both eaves courses using 38mm x 2.65mm aluminium nails.

TOP COURSES

- 1 For top tiles, use a course of eaves/top tiles, twice nail each tile as before.
- 2 Where a top course is formed under a window sill, dress a lead flashing down over top course tiles for at least 100mm, cut level or to an approved finish.

ANGLES

- 1 Use purpose-made internal or external angle tiles at all corners. Where necessary, clay angle tiles may require packing at the head to maintain a 'true' line with adjacent plain tiles.
- 2 Left and right hand angles of 90° (or other angle to suit) are available to provide a broken bond with main tiling, to be twice nailed (Figs. 18 and 19).
- 3 Lead soakers should be installed at special details such as mitred corners and wherever side lap is compromised (e.g., sprocket eaves).
- 4 Corner tiles are nailed through and not hung off lug on rear.

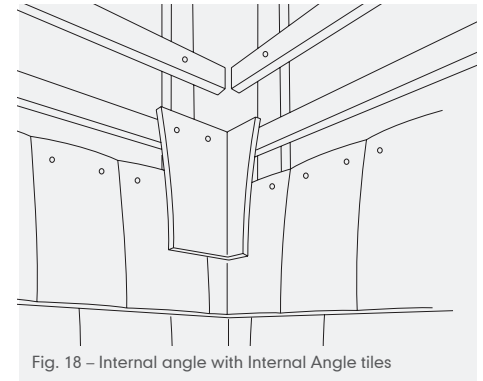

Fig. 18 – Internal angle with Internal Angle tiles

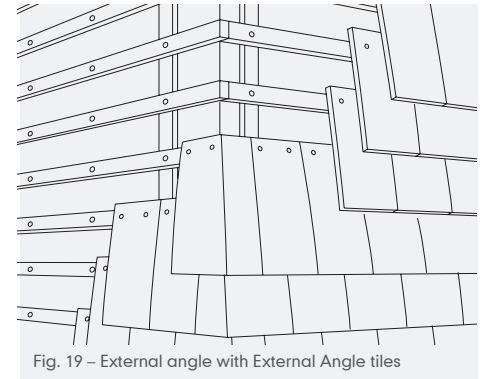

Fig. 19 – External angle with External Angle tiles

VERTICAL TILING

GABLES: 'WINCHESTER' CUT

This technique avoids the use of small triangular pieces of tile and ensures the secure fixing of the last tile against the main roof verge, by the use of a tile-and-a-half at the end of each course.

'Winchester' cutting is best suited for gable ends where the roof pitch is 40° or more. For lower pitches, the tiling gauge may need to be reduced to 100mm or 90mm in order to avoid too great a splayed cut.

On some courses, two tile-and-a-half tiles

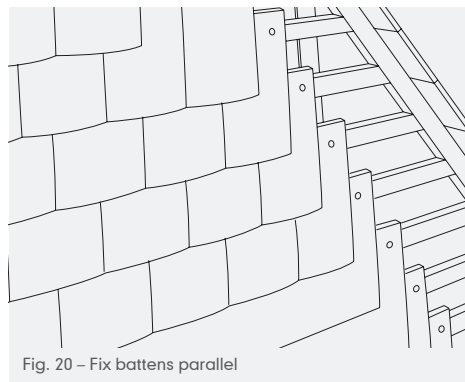

Fig. 20 – Fix battens parallel

adjacent to one another will be needed to overcome this.

- 1 Before installing the main battens, install one or more raking battens (or a 75-100mm x 25mm board) to the underside of the undercloak or overhanging soffit, to provide continuous fixing points for the cut tile-and-a-halves (Fig 20).

Note: To ensure symmetry, it is often useful to work outwards from a centre line, which should be marked or struck onto the battens before installing the tiles.

- 2 Cut tile-and-a-half tiles to angle of rake for each vertical course, cut edges

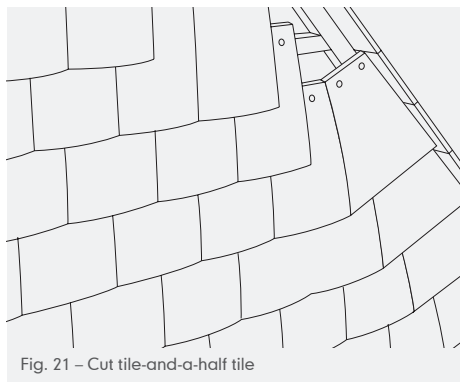

Fig. 21 – Cut tile-and-a-half tile

should be butted up to the underside of the undercloak or overhanging soffit. (Fig. 21).

- 3 Once tile-and-a-half tiles are positioned, cut adjacent tile to fit. All tile-and-a-half tiles should be twice nailed. This may mean drilling a second hole after cutting to shape or using adhesive to provide a second fixing.
- 4 At apex of gable, use a tile-and-a-half tile turned through 45° and cut to shape to finish (Fig. 22).

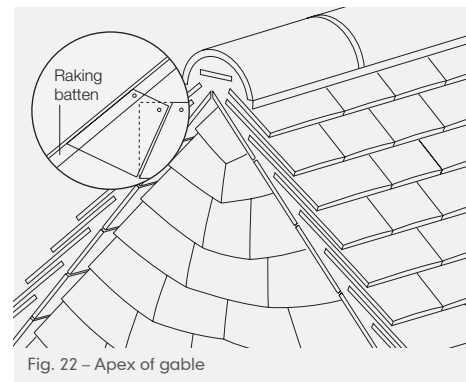

Fig. 22 – Apex of gable

VERTICAL TILING

GABLES: SOLDIER COURSE

This method is used for low pitch roofs below 35° where 'Winchester' cutting is impractical.

- 1 After felting and battening, fix one or more additional raking battens close to the undercloak/soffit etc.
- 2 Cut vertical tiles to meet raking batten using tile-and-a-half tiles at end of each course.
- 3 Fix courses of eaves/tops tiles to raking batten (Fig. 24).

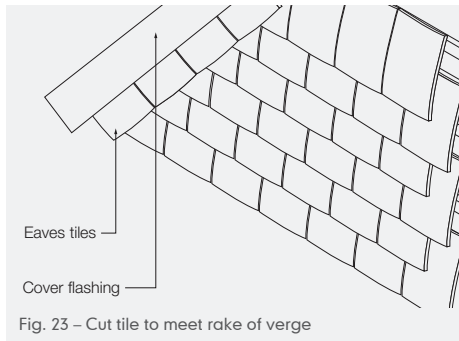

Fig. 23 – Cut tile to meet rake of verge

- 4 A cover flashing can be used to cover the soldier course tile nail holes and to the apex (Fig. 23).

GABLES: DOUBLE SOLDIER COURSE

An alternative to the single soldier course, where additional protection is required.

- 1 After felting, fix two raking battens close to undercloak/soffit positioned so as to allow the tiles to hang by their nibs.
- 2 Cut vertical tiles to meet lower raking batten using tile-and-a-half tiles at the end of each course.

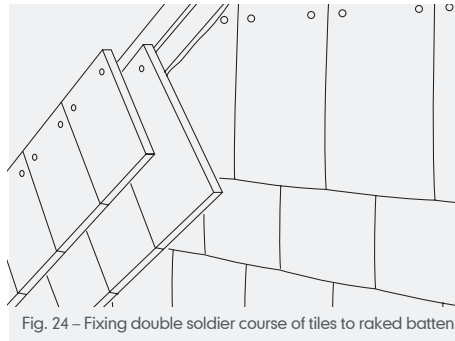

Fig. 24 – Fixing double soldier course of tiles to raked batten

- 3 Fix courses of standard Plain tiles to lower of two raked battens, then fix course of eaves tiles to remaining (top) raked batten (Fig. 24).
- 4 A cover flashing can be used to cover the soldier course tile nail holes and up to the apex.

Note: Spot bedding with a suitable adhesive is recommended beneath the laps of cut tiles to prevent wind chatter and damage.

It is not recommended that feature tiles are used for gable ends. If they are, however, use plain tile-and-a-half tiles to complete course beneath rake of the verge.

VERTICAL TILING

GABLES: SUSSEX CUT

- 1 Fix one or more battens or a 75-100mm x 25mm board over the main battens to provide continuous fixing points for the end tiles.
- 2 Form raking cuts using tile-and-a-half tiles as necessary (Fig. 25).
- 3 Fix standard tiles close to the undercloak/soffit by double nailing into the raking batten/s or board, and spot bedding in adhesive.

Note: some of the tile nibs may need removing on the end tiles (Fig. 26).

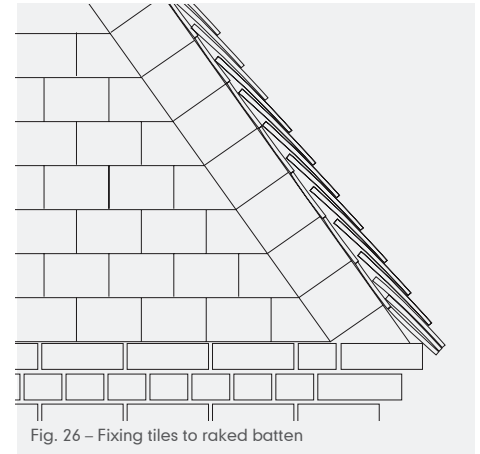
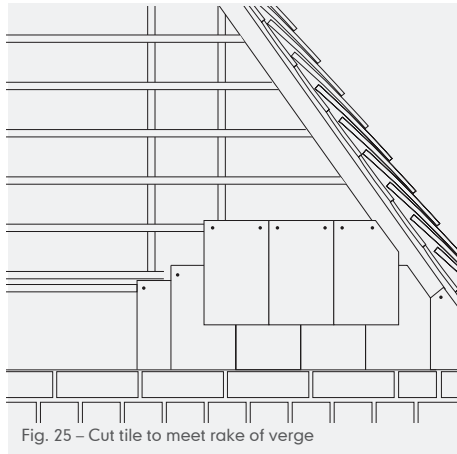

VERTICAL TILING

ABUTMENTS

Where the tiling meets an abutment, use tile-and-a-half tiles in alternate courses to provide a broken/half bond.

- 1 At internal corners, ensure end tiles or tile-and-a-half are twice nailed.
- 2 A Code 4 lead sheet can be taken a minimum of 75mm behind tiles and turned in a single welt on a vertical counter batten.
- 3 Lead is taken around corner and top edge taken into brickwork mortar joints (Fig. 27).
- 4 If lead soakers are used, slot them between tiles and turn along abutment wall.
- 5 Turn and dress the stepped flashing over soakers.
- 6 When meeting timber cladding or a window jamb, turn flashing behind cladding or return into the jamb (Fig. 28).

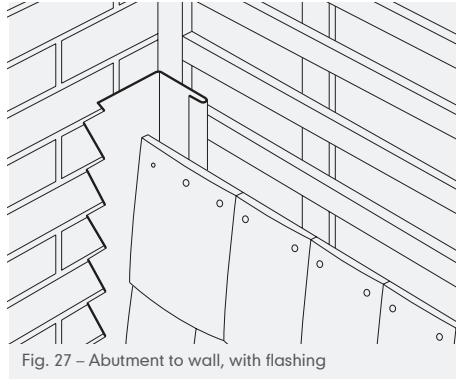

Fig. 27 – Abutment to wall, with flashing

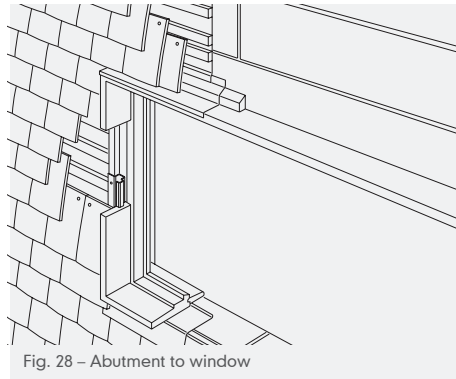

Fig. 28 – Abutment to window

Vertical tiling check points

- Ensure each Plain and feature tile is twice nailed on vertical tiling.
- Use double course of tiles at eaves and top edges
- Always use tile-and-a-half tiles at raking cut abutments.
- Maintain broken/half bond in all cases.
- Avoid using feature tiles on pitches below 70° unless adequate weathering is provided by additional groundwork.
- Ensure battens are securely fixed to groundwork with suitable fixings.
- For corner tiles ensure they hang off shank of nail rather than the lug on the reverse.
- Ensure corner tiles are fixed in position by double nailing and not hung from the strengthening nibs on the reverse.



CONCRETE AND CLAY INTERLOCKING TILES

- 98 Setting out the roof
- 103 Eaves
- 105 Verges
- 107 Valleys
- 109 Ashmore interlocking tiles
- 113 Lincoln clay profiled tiles

 Dry fix and ventilation systems
For more details, see pages 131-244

SETTING OUT THE ROOF

It is important that the tiler should set out the roof prior to fixing. This will help identify any out-of-square in the roof, avoid unequal overhangs (in particular with bedded verges) and ensure that the battens and tiles can be laid to a true line. (Fig. 1).

POSITION OF TOP AND BOTTOM BATTENS

1 Batten gauge required must be worked out on site. Fix or mark the eaves course batten first and position using one of the following methods:

- 2 The eaves batten should be set to ensure that the tail of the tile extends over the fascia board by no less than 50mm on the rake (Fig. 2).
- 3 To achieve this, measure from the underside of the tile nib to the tail of the tile to establish the hanging length, then extend your tape 50mm over the fascia board and mark off the position of the batten.
- 4 Fix top course batten so that ridge tile provides a minimum 75mm cover to top course tile (Fig. 3).

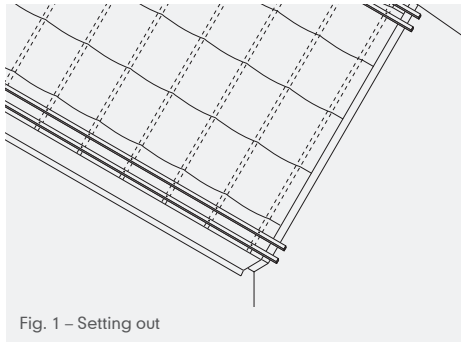

Fig. 1 – Setting out

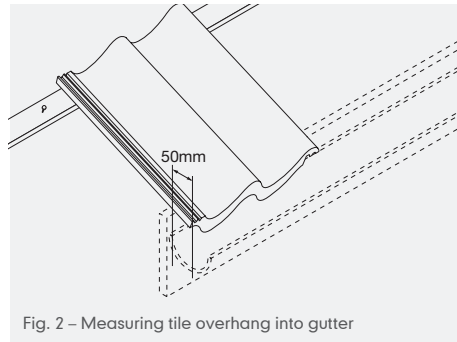

Fig. 2 – Measuring tile overhang into gutter

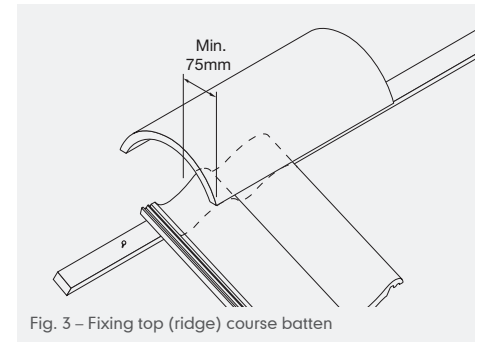

Fig. 3 – Fixing top (ridge) course batten

SETTING OUT THE ROOF

CALCULATING THE BATTEN GAUGE FOR VARIABLE GAUGE TILES

- 1 Measure distance between top of eaves batten and top of ridge batten.
- 2 Divide distance by maximum gauge of tile being used.
- 3 Round figure up to give number of courses up slope as a whole number.
- 4 Divide measured distance by number of courses to give batten gauge.
- 6 It is important, with deeply profiled tiles, to maintain an even gauge up roof to avoid a 'dog leg' diagonal.
- 7 If a short course is necessary tiles should only be cut in ridge course, drilled and nailed.

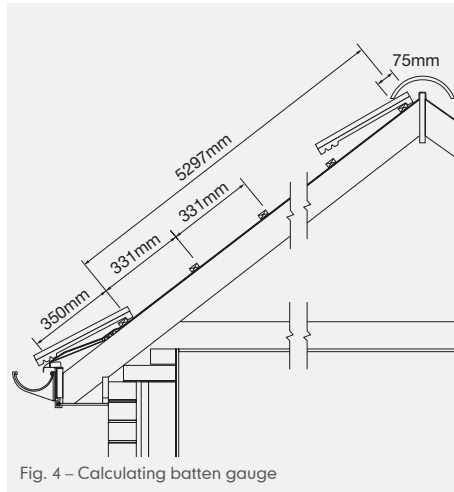

Fig. 4 – Calculating batten gauge

EXAMPLE (FIG. 4)

Distance eaves to ridge batten:	5297mm
Max. gauge for Mendip tiles:	345mm
No. of courses ($5297 \div 345$) =	15.35
15.35 rounded up:	16
Batten gauge ($5297 \div 16$):	331mm

Notes: The above applies only to a roof pitch with no features such as dormers, chimneys etc. Batten gauges between all such fixed points should be calculated individually.

SETTING OUT THE ROOF

HORIZONTAL ALIGNMENT

There are several ways of achieving true horizontal alignment:

- 1 To achieve accurate horizontal alignment, mark the positions of the batten gauges at each end of the roof and strike a chalk/ochre line between the points' (Fig. 5).

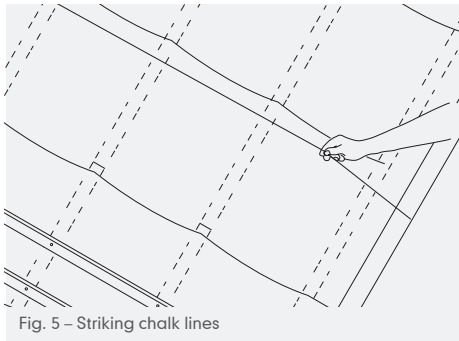

PERPENDICULAR ALIGNMENT

- 1 Set out roof along eaves starting with correct overhang at right hand verge.
- 2 Overhang on the left-hand verge can be adjusted by opening or closing the tiles where necessary to achieve a full tile finish, or to ensure that small cuts are avoided.
- 3 Marley interlocking tiles allow a tolerance ('shunt') of approximately 3mm in side lock for adjustment (Fig. 6).

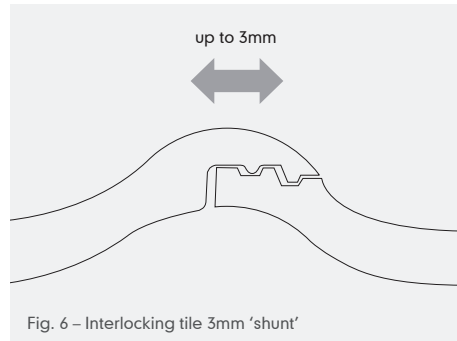

- 4 Overhang at verges should be 30-60mm for bedded verges with undercloak, and up to 50mm for dry verge systems.
- 5 Where tiles require cutting at the verge, the cuts should be at least half width of a full tile. Where this is not possible, small pieces of tiles should be bonded to the next full tile using a suitable adhesive and include at least one other mechanical fixing.
- 6 Lay tiles at the average width/shunt across the roof on the top and bottom battens. Alternatively, transfer the marks from a gauge rod/markings batten representing the average width/shunt of three tiles.
- 7 Strike perpendicular chalk or ochre lines from eaves to ridge at three tile intervals to coincide with edges of tiles.

SETTING OUT THE ROOF

ACHIEVING BROKEN BOND PATTERN (DUO MODERN AND DUO EDGEMERE)

Duo Modern and Duo Edgemere interlocking tiles are laid quarter bonded, using half or three-quarter width tiles at verges, cut on site.

- 1 Ensure that the eaves course right hand or left hand verge starts with either a three-quarter width, half width or standard tile as indicated in Figs. 7 and 8.
- 2 Continue subsequent courses of slates laid in a quarter bond, ensuring that left and right verge tiles are cut as either half tiles, three quarter tiles or standard tiles (see Fig. 8).
- 3 Mechanically fix all tiles by either nailing, clipping, or nailing and clipping in accordance with the recommended fixing specification.

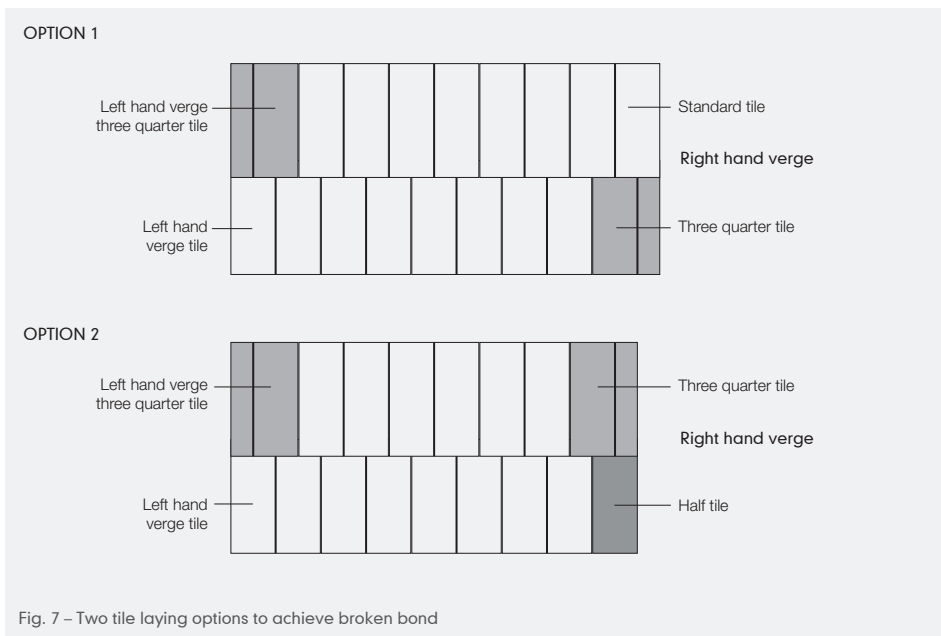
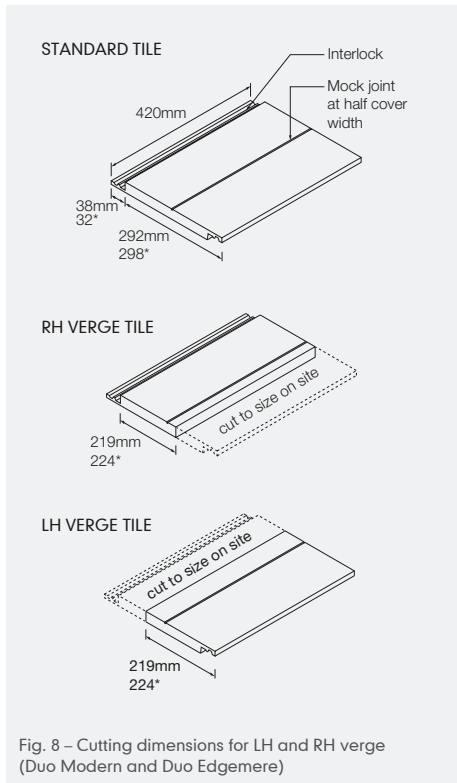

Fig. 7 – Two tile laying options to achieve broken bond

SETTING OUT THE ROOF



* dimension for Duo Edgemere

COMPLETION OF TILING

- 1 Load out all tiles on the roof evenly before commencing tiling (see page 11).
- 2 Work from right to left in columns, using the battens as safe footholds (Fig 9)
- 3 On a hipped roof, cut tiles so that end tiles of each course align with rake of hip.

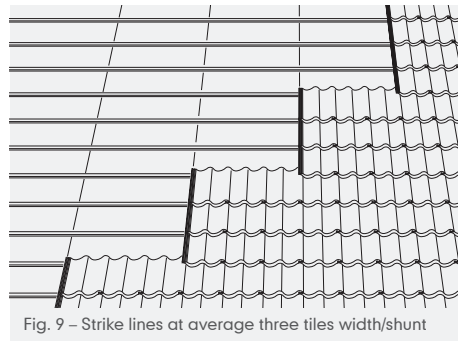

Setting out check points

- Never exceed maximum gauge for tile used at recommended pitch.
- Minimise tile cutting wherever possible.
- Tiles at the verge should not be cut less than ½ tile.
- Ensure ridge tiles provide a minimum 75mm cover to top course tiles.
- Eaves tiles should extend over the fascia board 50mm on the rake.

EAVES

INTERLOCKING TILES

- 1 Install underlay support trays or 5U felt over timber support at the eaves.
- 2 Eaves tiles should overhang the fascia board 50mm (Fig. 10).
- 3 If gutter is not fixed, an overhang of min. 50mm should be allowed (Fig. 11).

Note: Fascia heights shown in tables on page 132. It is essential to ensure the fascia board is set at the correct height for the tiles and roof pitch, the height should be checked before any underlay or battens are installed.

- 4 Fit underlay protector or draw underlay taut over tilting fillet and front edge of fascia board before fixing.

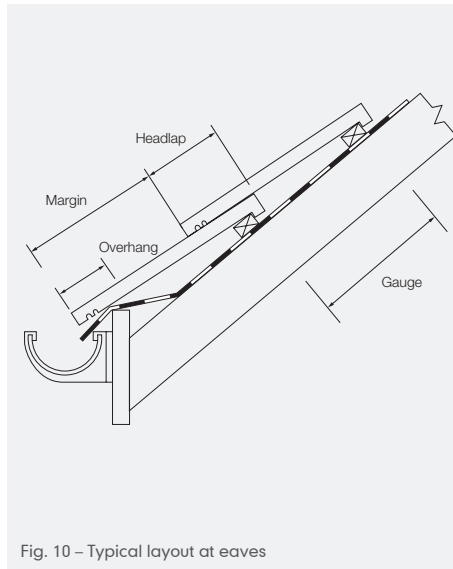

Fig. 10 – Typical layout at eaves

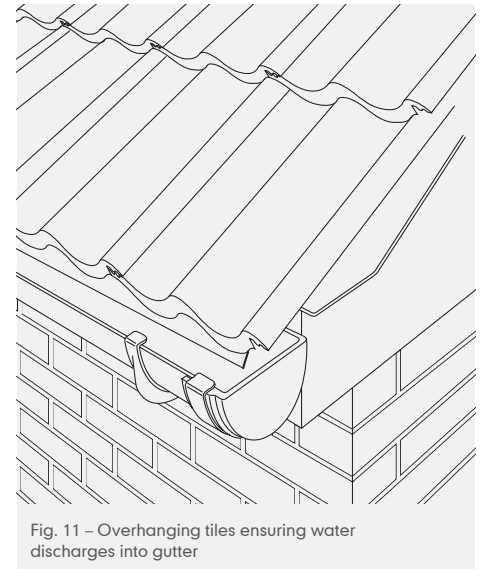

Fig. 11 – Overhanging tiles ensuring water discharges into gutter

EAVES

4 Fix eaves course tiles with nail or purpose-made eaves clip nailed to top of fascia board (Fig. 12).

5 If fascia board has been fixed at correct height, eaves course will automatically be at correct pitch (see page 136).

Note: Sprockets are not recommended with interlocking tiles.

6 Eaves ventilation should be provided for all new projects without a vapour control layer.

7 For deep profile tiles, nail comb filler to top of fascia board (Fig. 13).

Note:

1. Eaves ventilation can be achieved unobtrusively by using Marley Universal eaves ventilation systems (10mm and 25mm). See page 249 for Eaves fascia heights without ventilation.
2. If fixing into plastic fascia, please contact the fascia board manufacturer for appropriate fixing type.

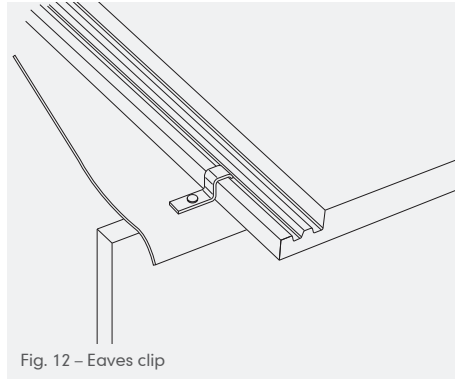

Fig. 12 – Eaves clip

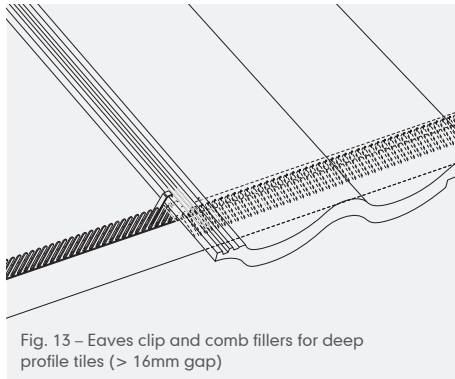

Fig. 13 – Eaves clip and comb fillers for deep profile tiles (> 16mm gap)

Eaves check points

- Nail or clip all eaves tiles as per fixing specification recommendations.
- Ensure eaves course tiles do not fall below the minimum recommended pitch for the type of tile.
- Where appropriate, fit correct eaves comb filler strip.
- Use Marley Eaves Ventilation Systems
- If above is not used, a tilting fillet or fascia must take its place.
- Eaves tiles should extend over the fascia board 50mm on the rake.

MORTAR BEDDED VERGES

GROUNDWORK

- 1 Form verges by bedding tiles onto undercloak of fibre cement strip (1200mm x 150mm).
- 2 Lay undercloak rough side upwards, closely butted together, with a slight tilt outwards to provide drip at outside edge.
- 3 Level off irregularities in brickwork by laying undercloak onto a bed of mortar or exterior grade mastic, bringing height up to adjacent rafter.
- 4 Carry roofing underlay over cavity wall and cover by inside edge of undercloak.
- 5 When laid on boarding, nail each length of undercloak at maximum of 300mm centres.

TILING BATTENS

- 1 Tiling battens should finish 25-50mm from the edge of the undercloak.
- 2 Place undercloak below battens, overhanging by maximum of 50mm for plain tiles, and 60mm for single-lap tiles (Fig. 14).
- 3 Provide about 100mm of compressed mortar.
- 4 Ensure that cut batten ends are coated with a suitable timber treatment.
- 5 Bed all verge tiles and fix either by nailing or clipping as required by fixing specification.

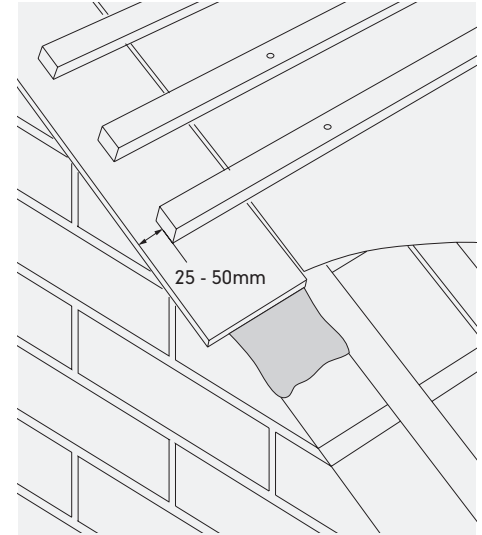

Fig. 14 – Fibre cement undercloak fitted over tiling batten

MORTAR BEDDED VERGES

EXTERNAL CLIPPING

- 1 When required, nail verge clips to top of battens with upstand level with edge of undercloak (Fig. 15).
- 2 Where possible, set the roof out to avoid cutting. Where cut tiles are required at the verge, they should be no less than $\frac{1}{2}$ tile wide with two mechanical fixings.
- 3 When cutting profiled tiles, care must be taken to ensure that verge clips can still be fitted correctly.
- 4 Strike all mortar bedding off flush and neatly point.

VERGE TILE AT EAVES

- 1 Verge tiles at eaves should overhang by same amount as rest of tiling.
- 2 It may be necessary to notch out a small piece of the undercloak where it meets the fascia board to prevent first tile from riding up.

CLOAK VERGES FOR INTERLOCKING TILES

See pages 161-164.

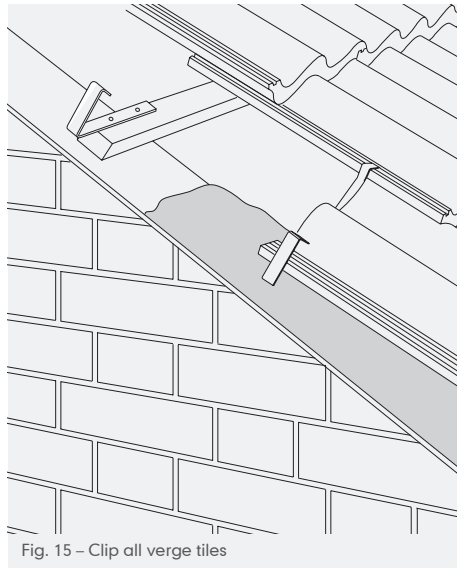

Fig. 15 – Clip all verge tiles

Verge check points

- Twice mechanically fix all verge tiles.
- Continue underlay across wall cavity and below undercloak (where appropriate).
- Mortared verges should have an overhang of 38mm to 50mm for plain tiles, and 30mm to 60mm for single-lap tiles.
- Undercloak should have an outward tilt on mortared verges.
- Bedding and pointing should be done using the same mix.

METAL LINED VALLEYS

METAL VALLEYS

Sheet metal valleys can be used at roof pitches down to 15°, and are especially useful where a valley forms a junction between slopes of different pitch.

Metal used to form the valley should be not less than 500mm wide, and should extend a minimum of 250mm up each side of the valley (Fig. 16).

VALLEY WIDTHS

A traditional valley gutter width of 125mm is satisfactory for most roofs. For pitches below 35°, or valley lengths exceeding 5 metres, valley width may require increasing to cope with the additional flow experienced during storm conditions.

SUPPORT FOR METAL VALLEY LININGS

- 1 Support all metal linings adequately along their entire length.
- 2 Valley boards may be inset into suitably housed traditional rafters, or fitted between trussed rafters.
- 3 Lay a 4mm thick ply lining board over valley boards to provide a smooth surface for metal lining.

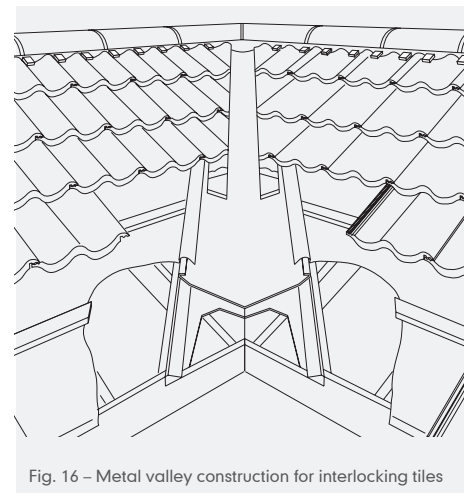

Fig. 16 – Metal valley construction for interlocking tiles

METAL LINED VALLEYS

LEAD SHEET VALLEYS

Where lead is used, use minimum Code 4, preferably Code 5. To avoid staining, the Lead Sheet Association recommends an application of patination oil immediately after the lead is fixed.

- 1 Dress metal lining down tightly onto lay boards and fix in lengths not exceeding 1500mm with copper nails across the top of each piece.
- 2 Laps should be a min. 150mm although below 30°, this increases to 290mm min. at 15° valley pitch (see LSTA recommendations).
- 3 Dress metal lining over tilting fillets at each side of valley and turn back the edges' to form a welt.
- 4 Restrict any fixings down sides to top third of each piece of valley lining.
- 5 Cut roofing underlay so that it laps over tilting fillets.
- 6 Cut roof tiles to a rake and bed with mortar onto a suitable undercloak laid onto lead lining. Ensure that tile interlocks are kept free and a gap is maintained between tilting fillets and mortar bedding.
- 7 Never lay mortar directly onto lead as there is a risk of differential movement causing mortar to crack and lead to split.
- 8 Nail or clip all tiles adjacent to valley and ensure small tile cuts are well bedded in mortar, using Marley secret cut tile clips.

Valley check points

- Keep an open channel between cut edges of roof tiles (125mm minimum).
- Do not block interlock laps of tiles with mortar since this may cause water damming.
- Do not lay bituminous underlay directly beneath a lead valley; heat causes underlay to expand. This may split lead.
- Do not apply mortar direct to lead.
- Tile slips or undercloak beneath mortar bedding is generally recommended to prevent differential movement between the mortar and lead lining.
- Twice mechanically fix all tiles either side of valley.

ASHMORE INTERLOCKING TILES

Ashmore single lap interlocking roof tiles have a 'mock bond' joint to give the appearance of two traditional double-lap plain tiles when laid on the roof. Tiles are laid single lap with a broken bond, utilising left hand and right hand 3/4 tiles for use in alternate courses at verges and abutments. Tile-and-a-half tiles are also available to assist with setting out to hips and valleys to avoid small cut sections of tile.

SETTING OUT

- 1 Position the eaves course batten so that the leading edge of the tile extends over the fascia board by 50mm on the rake. To achieve this, measure from the underside of the tile nib to the tail of the tile to establish the hanging length, then extend your tape 50mm over the fascia board and mark off the position of the batten.
- 2 Measure distance between the top of eaves batten and top of ridge course batten. Divide distance by 190mm (maximum gauge of Ashmore tile). Round this figure up to give number of courses up roof slope as a whole number.
Divide measured distance by number of courses to give required batten gauge.
- 3 Where two roof slopes of varying pitch intersect, set batten gauge to the lower pitch or longer rafter length.
- 4 Mark the position of the battens onto the underlay at each end of the roof and strike chalk lines between the points to ensure accurate horizontal alignment. Large roofs may need one or more intermediate marking points.
- 5 Check perpendicular alignment by setting out roof along eaves starting with correct overhang at the right hand verge. Overhang at left hand verge can be achieved using full and 3/4 tiles by opening or closing side lock shunt (in line with BS5534 for single-lap tiles, max. verge overhang 50-60mm).
- 6 Cut tiles at verge should never be less than 3/4 the width of a standard tile, unless cut from a tile-and-a-half tile.

ASHMORE INTERLOCKING TILES

FIXING

Before commencing to tile the roof, check to ensure the correct fixing specification is being used.

Ashmore tiles should be mechanically fixed in the following manner:

Step A: All tiles requiring once nailing should be nailed through right hand nail hole using a 45mm x 3.35mm aluminium or stainless steel nail.

Step B: Tiles requiring clipping should be nailed through the left hand nail hole using a 45mm x 3.35mm aluminium or stainless steel nail and clipped using Ashmore stainless steel wire clip, which is located over side lock of tile with tail push fitted under back edge of the nailed course of tiles beneath.

Note: Fixings into PVC or other non-timber fascia boards should be suitable for the material and provide sufficient pull out resistance.

EAVES

- 1 The eaves course of tiles may be fixed by either nailing or clipping, or both.
- 2 Purpose made eaves clips are nailed to fascia board and located over side lock of the eaves course tile (Fig. 17).
- 3 Eaves course must be laid at same pitch as remainder of roof.
- 4 Care should be taken to adjust height of fascia or tilting fillet to accommodate any eaves vent strips (see tables on page 136).

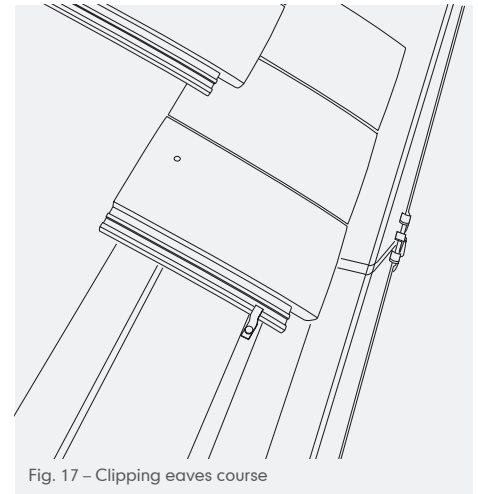

Fig. 17 – Clipping eaves course

ASHMORE INTERLOCKING TILES

BEDDED VERGES

- Verges should be formed using standard tiles with left hand or right hand 3/4 width verge tiles in alternate courses. Standard tiles on left hand verges will require the sidelock to be removed (Fig. 18).
- Form verges by mortar bedding tiles onto an undercloak of fibre reinforced cement strip (1200mm x 150mm).
- Lay undercloak rough side up and closely butted together with a slight tilt outwards to provide a drip edge with a maximum 60mm overhang from brickwork gable or bargeboard.
- Provide 100mm of compressed mortar to bed all verge tiles and fix each verge tile by twice nailing and clipping as per specification.
- Use purpose made verge clips on both left hand and right hand verges and twice nailed to battens with upstand level with edge of the undercloak.

- Strike all mortar bedding off flush and neatly point in one operation.
For Ashmore Dry verge system, see pages 150-155.

RIDGES

- Roof apices may be covered using Marley segmental ridge tiles or any other ridge tile design suitable for the pitch of the roof (see Marley Roofing Product Catalogue).
- Edge-bed all mortar bedded ridge tiles onto top course of tiles with solid bedding at butt joints.
- Support mortar at butt joints with pieces of cut tile.
- Ensure that a minimum 75mm cover is provided by ridge tile over top course of tiles with any exposed mortar neatly pointed (Fig. 19).
- Ensure all ridge tiles are mechanically fixed.

Note: For details of Marley Dry Ridge systems refer to pages 189-208.

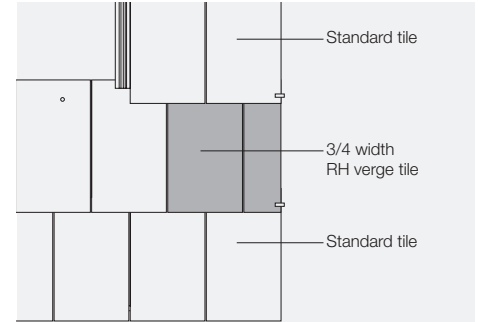

Fig. 18 – Typical bedded verge (right hand)

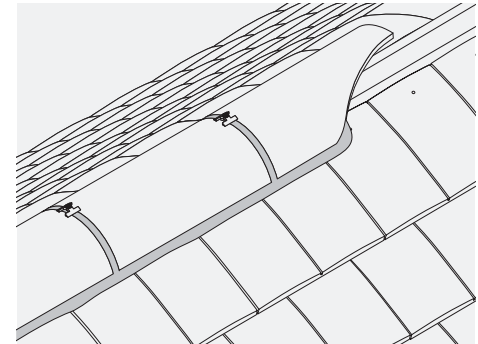

Fig. 19 – Typical bedded ridge

ASHMORE INTERLOCKING TILES



Fig. 20 – Typical bedded hip using third round ridge units as hip capping, tile-and-a-half tiles shown shaded

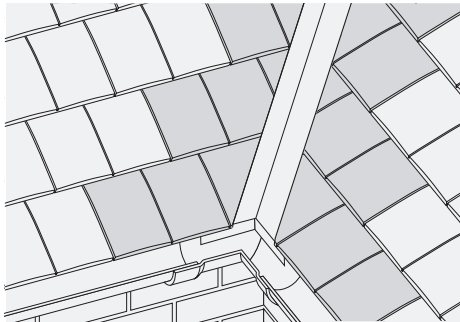

Fig. 21 – Typical bedded valley – tile-and-a-half tiles shown shaded

HIPS

Hips should be formed using tiles and tile-and-a-half where necessary to avoid small cuts, each tile being twice nailed or nailed and clipped.

- 1 Cut tiles to rake of hip and cover with third round hip tiles or alternative suitable hip tiles, edge bedded, with solid bedding at butt joints, onto adjacent tiles. Support mortar at butt joints with pieces of cut tile.
- 2 Ensure that a minimum 75mm cover is provided by hip tile over adjacent courses of tiles with any exposed mortar neatly pointed.
- 3 Fix a hip iron at base of hip rafter and shape first hip tile at front to align with tiling at the eaves (unless installing a block end hip tile).
- 4 Ensure all hip tiles are mechanically fixed.

- 5 Mitre junction of hip and ridge, using a concealed lead saddle or Flexfast lead replacement flashing in exposed locations.

Note: For details of Marley dry hip systems refer to pages 170-181.

VALLEYS

Valleys should be formed using tiles and tile-and-a-half where necessary to avoid small cuts, each tile being nailed and clipped.

- 1 Cut tiles to rake of valley trough, leaving a clear channel of minimum 125mm wide.
- 2 Form valley with either a metal lining (Code 4 lead sheet) of not less than 500mm wide (see LSTA recommendations) or with the Marley GRP dry valley (low profile).
- 3 Bed raking cut tiles at edges of valley using mortar, ensuring that there is adequate space kept clear behind mortar to avoid water capillarity (Fig. 21).

Note: For details of Marley Universal dry valley system refer to pages 182-185.

LINCOLN CLAY PROFILED TILES

Lincoln clay interlocking roof tiles have the appearance of a traditional clay pantile when laid on the roof. Tiles are laid single lap with a straight bond.

Clay ridges and hips are compatible with Marley's mortar fixing kits and Universal dry fix accessories. Denti slips are also available for traditionally bedded ridges and hips.

SETTING OUT – EAVES TO RIDGE

- 1 Lincoln tiles have an open gauge, which can be adjusted up to a maximum spacing of 300mm to ensure a minimum headlap of 75mm (Fig. 22).
- 2 Position the eaves course batten to allow the bottom edge of the eaves course tiles to overhang the fascia board, so that water discharges into the centre of the gutter.

If no gutter is fixed a minimum of 50mm on the rake should be allowed for.

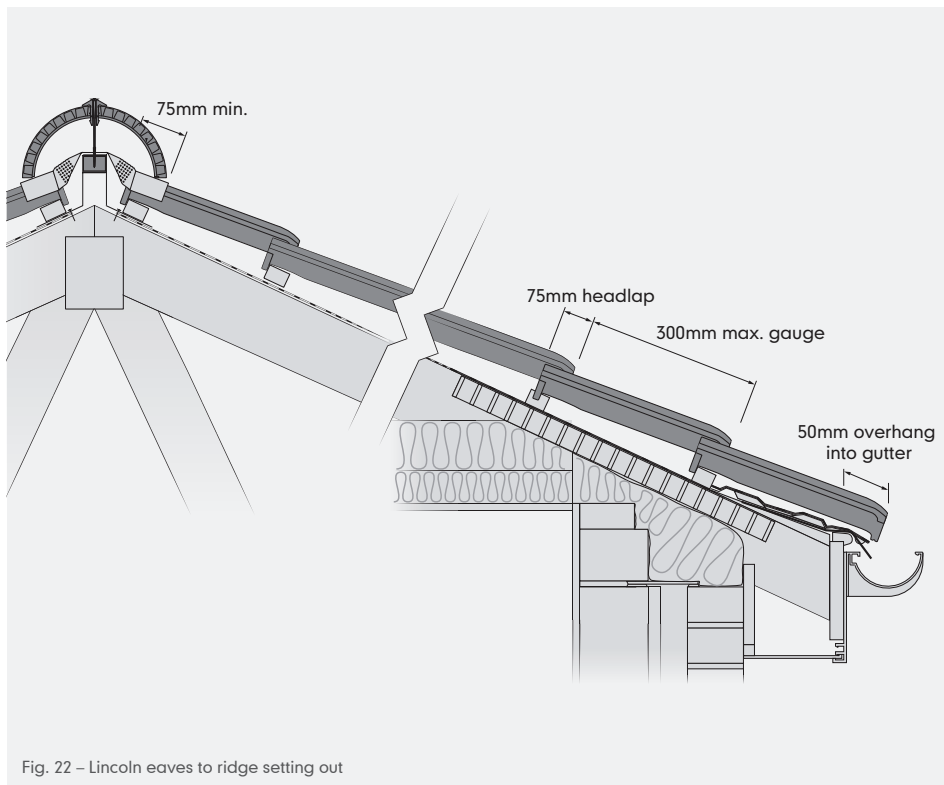

Fig. 22 – Lincoln eaves to ridge setting out

LINCOLN CLAY PROFILED TILES

- 3 Measure the distance between the top of the eaves batten and the top of the ridge course batten, which should be fixed so that the ridge tile provides a minimum 75mm cover over top course tile.
- 4 Divide the distance by the maximum batten gauge for the required headlap. Divide the measured distance by the number of courses to give the required batten gauge.
- 5 Tiles should be nailed using a 38mm x 3.35mm aluminium nail and/or clipped with SoloFix. Both fixings must be used at the top course.

SETTING OUT ACROSS THE ROOF

The average linear coverage (cover width) of the Lincoln tile is 224mm. There is up to 3mm adjustment (shunt) built into the side interlocks to aid setting out across the roof.

- 1 For maximum adjustment, particularly with clay tiles, it is recommended to lay the first course of tiles with intermediate shunt of 1.5mm. This enables the tiles to be opened or closed for best fit, working up the roof.
- 2 Ensure that tiles at the verge overhang 30-60mm and are equal on both left- and right-hand verges.
- 3 Lay the top course of tiles using the shunt to achieve best fit. Mark every third tile on the top course and eaves course and strike lines between.

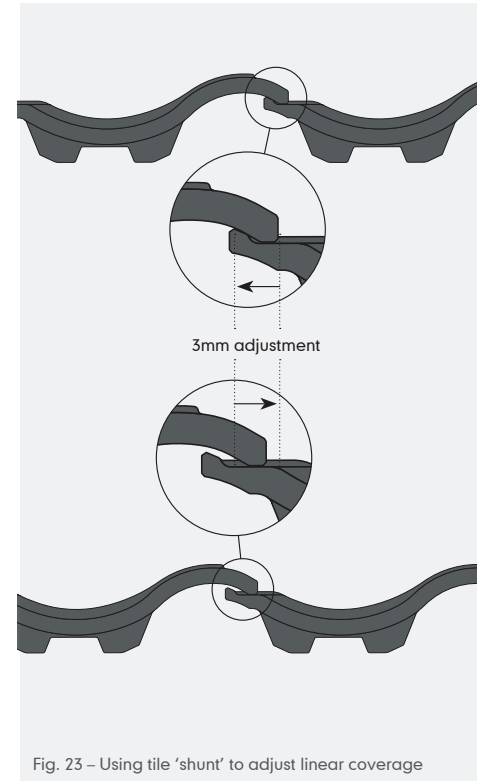

Fig. 23 – Using tile 'shunt' to adjust linear coverage

LINCOLN CLAY PROFILED TILES

USING A GAUGING ROD

- 1 An alternative method is to use a gauging rod (a short length of batten) and mark the position of three tiles with their sidelocks fully closed, then mark the position of the three tiles 'open'. Set the average coverage by making a third mark midway between the two previous two marks on the rod.

Use this third position to set out the linear coverage on both eaves and top course battens.

- 2 Strike a chalk or ochre line from the eaves to ridge at each mark so that the tiles can be laid to a straight perpendicular alignment.

ALIGNMENT AND CUTTING OF TILES

- 1 The left-hand verge should be finished with a standard tile (30mm-60mm overhang).
- 2 Cut tiles at the verge should be avoided wherever possible, but if this is unavoidable, they should never be less than half the width of the standard tile.

GENERAL FIXING

Before commencing to tile the roof, check to ensure the correct fixing specification is being used. Load out all sides of the roof uniformly, randomly mixing tiles from at least three pallets.

Lincoln tiles should be laid straight bonded, commencing at the right hand side of the roof and working up and across the roof from right to left in columns, using the battens as safe footholds.

- 1 Tiles can be fixed using a 38mm x 3.35mm aluminium nail.
- 2 Tiles requiring once clipping should be fixed using a one piece SoloFix tile clip, located over the side lock of the tile (Fig. 24).
- 3 Tiles requiring clipping and nailing (side and head) should be fixed using a SoloFix tile clip, located over the side lock of the tile, and head nailed using a 38mm x 3.35mm aluminium nail.

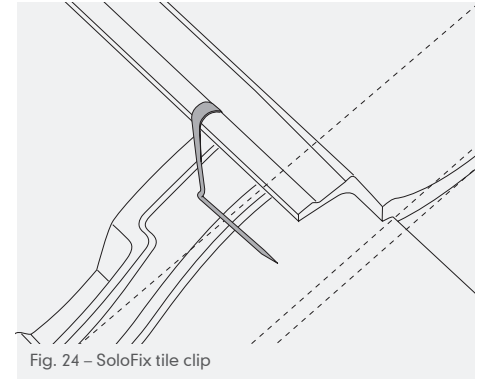

Fig. 24 – SoloFix tile clip

LINCOLN CLAY PROFILED TILES

EAVES

The eaves course tiles should be laid at the same pitch as the remainder of the roof with the fascia board or tilting fillet fixed at the correct height, taking account of any over fascia ventilation strip.

- 1 The roof underlay should be laid onto a support tray and set back from exposure. (Fig. 25).
- 2 All eaves course tiles should be twice fixed; nailed with 38mm x 3.35mm aluminium nail and clipped using a Lincoln eaves clip nailed to the fascia or tilting fillet (Fig. 26).
- 3 A comb filler strip should be fitted above the fascia/tilting fillet/eaves vent strip to prevent the ingress of birds or vermin.
- 4 Position the eaves course batten to allow the bottom edge of the eaves course tiles to overhang the fascia board by 50mm into the gutter.

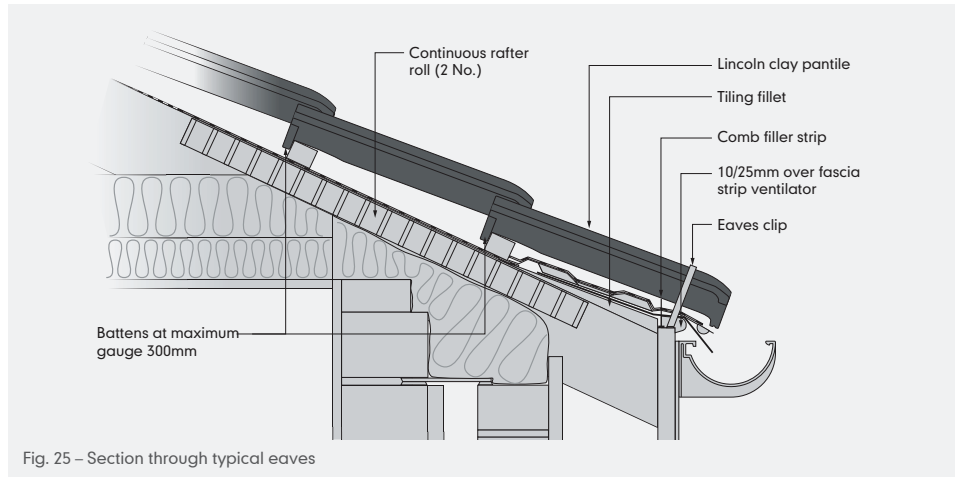

Fig. 25 – Section through typical eaves

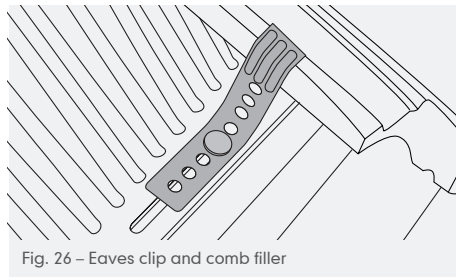

Fig. 26 – Eaves clip and comb filler

LINCOLN CLAY PROFILED TILES

BEDDED VERGES

Left and right-handed verges should be formed with standard tiles.

- 1 Verges should be formed by mortar bedding the tiles onto an undercloak of fibre reinforced cement strip (1200mm x 150mm).
- 2 Lay the strips of undercloak rough side up and closely butted together, with a slight tilt outwards to provide a drip edge with a 30mm-60mm overhang from the brickwork gable or bargeboard.
- 3 Provide 100mm of compressed mortar to bed all verge tiles. Fix each verge tile with at least two mechanical fixings.
- 4 Head nail each verge tile using 38mm x 3.35mm aluminium nails and purpose-made Lincoln verge clips (left hand and right hand).
- 5 Twice nail the verge clips to the battens with two clout nails no less than 25mm x 2.65mm nails and ensure upstand is level with the undercloak.
- 6 Ensure that the bedding and pointing is completed using the same mix.

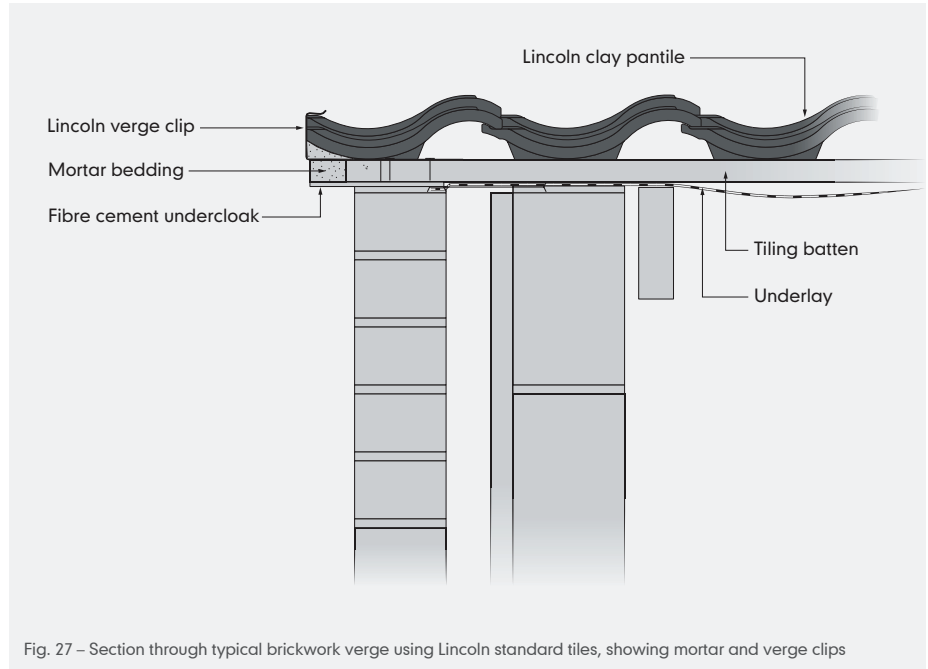

LINCOLN CLAY PROFILED TILES

UNIVERSAL RIDGEFAST

For use with 450mm clay half round ridges, RidgeFast provides a simple and rapidly installed dry fixed ridge system (Fig 28). A clay ridge end tile, which is pre-holed for fixing, should be used at the gable ends.

100mm x 4.8mm screw packs for deep ridges should be used for fixing the union clamps (see page 190).



Fig. 28 – Ridge end with Universal RidgeFast

BEDDED RIDGES WITH 450mm HALF ROUND RIDGES

The roof apex should be covered using 450mm clay half round ridge, edge bedded onto the top course of tiles, over a row of dentil slips secured into the pans.

- 1 Ensure that a minimum 75mm cover is provided by the ridge tile over the top course of tiles with any exposed mortar neatly pointed.

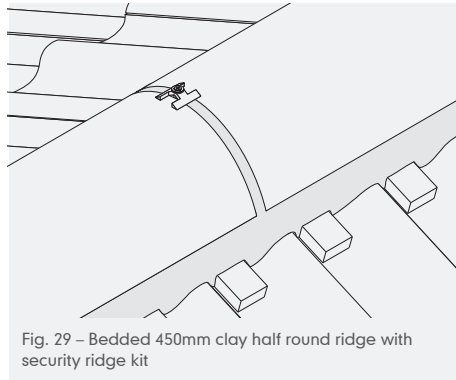

Fig. 29 – Bedded 450mm clay half round ridge with security ridge kit

- 2 Mortar bedded ridges should also be mechanically fixed using Marley mortar bedded security ridge fixing kits and 100mm x 4.8mm screw packs for deep ridges (Fig. 29).

Dentil slips should be fixed to batten with 75mm nail through the pre-drilled hole in the dentil slip and tile.

- 3 Marley recommend finishing the ridge with a 450mm half round ridge end tile, which is pre-holed for fixing. Ridge ends should be fixed using 100mm x 4.8mm screw packs for deep ridges.

LINCOLN CLAY PROFILED TILES

BEDDED HIPS WITH 450mm THIRD ROUND HIP

- 1 Cut tiles to the rake of the hip and cover with 450mm clay third round hip tiles, edge bedded and solid bedded at joints, with dentil slips bedded in the pans of the adjacent raking cut tiles.
- 2 Ensure that a minimum 75mm cover is provided by the hip tile over the adjacent courses of tiles with any exposed mortar neatly pointed.
- 3 Mortar bedded hip tiles must also be mechanically fixed using Marley mortar bedded security hip fixing kits (Fig. 30).

- 4 Marley recommend finishing the hip with a third round hip end tile, which is pre-holed for fixing.
- 5 Mitre the junction of the hip and ridge, using a lead saddle in exposed locations.

UNIVERSAL HIPFAST

For use with 450mm clay third round hip tiles, HipFast provides a simple and rapidly installed, dry fixed ridge system. A 450mm clay hip end tile, which is pre-holed for fixing, should be used at the hip ends (Fig. 31). See pages 170-175.

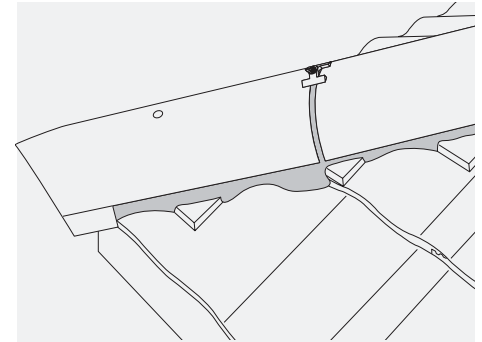

Fig. 30 – Hip end tile with mortar bedded security fixing kit

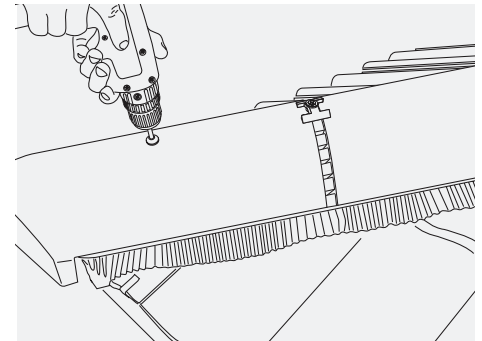

Fig. 31 – Mechanically fixed hip end using HipFast system

LINCOLN CLAY PROFILED TILES

BEDDED VALLEY

- 1 Cut tiles to the rake of the valley trough, leaving a clear channel of minimum 125mm wide.
- 2 Form the valley with either a metal lining (Code 4 or 5 lead sheet) of not less than 500mm wide (see LSTA recommendations).
- 3 Bed raking cut tiles at the edges of the valley using mortar, ensuring that tile interlocks are kept free and there is adequate space kept clear behind the mortar to avoid water capillarity.
- 4 Ensure the mortar is laid onto a fibre cement undercloak strip above the lead valley gutter lining.
- 5 All tiles adjacent to the valley should be twice fixed and any small cut pieces of tile should be mechanically fixed using Marley head clips or retention clips (Fig. 32).

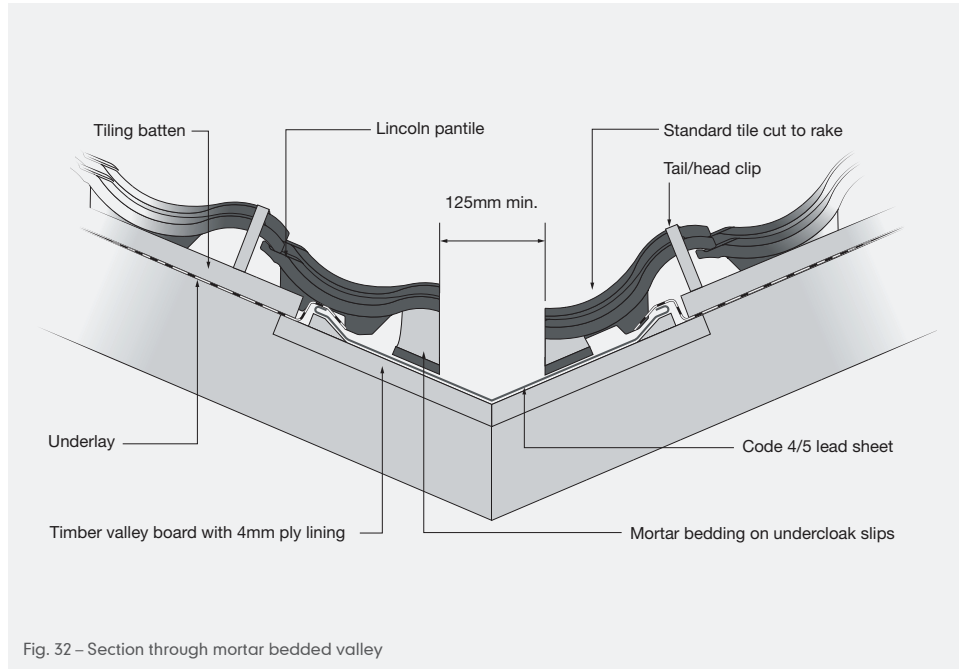
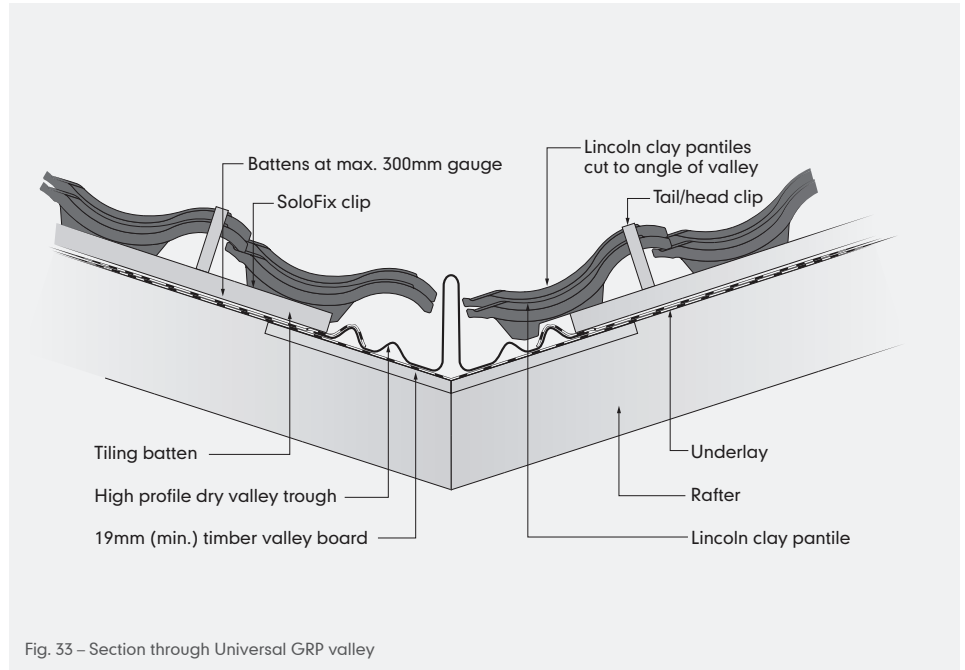

Fig. 32 – Section through mortar bedded valley

LINCOLN CLAY PROFILED TILES

UNIVERSAL GRP VALLEY

The Marley Universal high profile dry valley system (Fig. 33) is suitable for use with Lincoln clay pantiles for a completely mortar-free fixing solution, see pages 182-185.





SHINGLES AND SHAKES

- 123 Setting out
- 124 General laying
- 126 Eaves
- 127 Ridges
- 128 Hips and valleys
- 129 Vertical applications
- 130 Coverage

SETTING OUT

The top edge of the first batten should be fixed at gauge + 38mm + half batten width, when measured from (no less than) 38mm over the fascia board. The remaining battens should be fixed at the recommended gauge for the roof pitch.

Shingles should be spaced 6mm apart and twice nailed. The nails should be fixed 19mm in from the edge and 38mm above the butt of the course above.

Side lap should be no less than 38mm and joints on alternate courses should be off set.

Battens should comply to BS 5534. Marley recommends JB Red factory graded battens, minimum size 38mm x 25mm (N.B. 25mm x 50mm offer a larger fixing area).

Shingles can be used over a variety of roof types – boarded roofs, metal decks and warm roof construction. Care should be taken to follow current building regulations and individual specifications can be determined in conjunction with the insulation manufacturer.

For the purposes of ventilation, shingles should be regarded as an air impermeable roof covering and in certain circumstances, counter battens may be required.

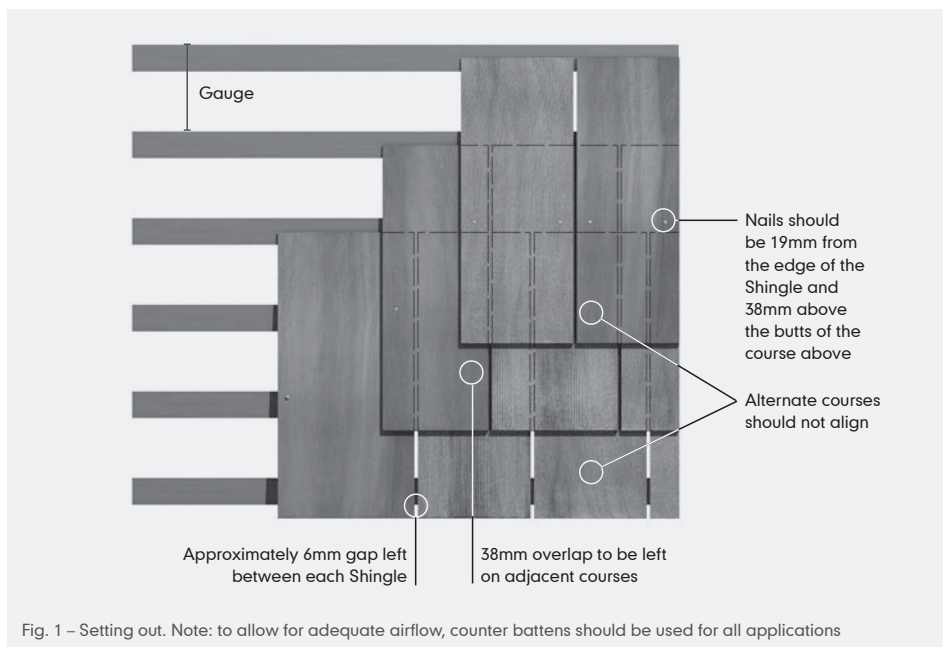

Fig. 1 – Setting out. Note: to allow for adequate airflow, counter battens should be used for all applications

GENERAL LAYING

- 1 Getting started: spend some time selecting the best face of the shingles.
 - 2 A double eaves course is required and should overhang 38mm into the gutter (Fig. 2)
- A broken bond pattern should be maintained and shingles should be twice nailed or stapled.
- 3 Mark butt line and nailing point with a chalk line or use a 125mm wide piece of timber and a 38mm batten respectively. (Fig 3).
 - 4 Continue laying courses of shingles up roof slope (Fig. 4).
 - 5 Shingles can be easily trimmed to size using a straight edge and sharp knife (Fig. 5).

FIXINGS

Marley recommends 2 x 31mm x 1.8mm stainless steel nails per shingle and 4 x 45mm x 2.65mm stainless steel nails for Hip & Ridge capping.

CONDITIONING

Marley recommend that all timber handled on site is managed as per BS 8000-5 and 6: Workmanship on Building Sites.

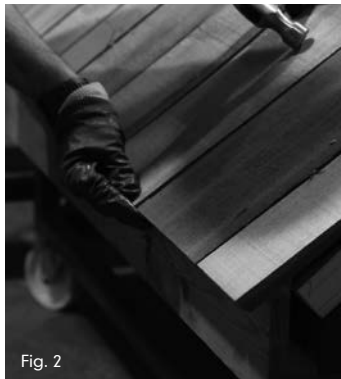

Fig. 2



Fig. 3

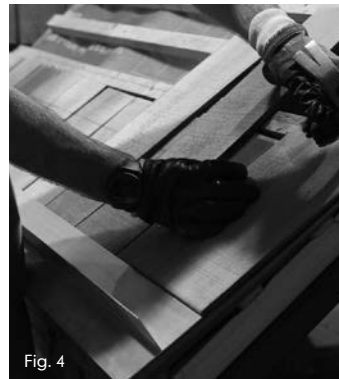

Fig. 4



Fig. 5

GENERAL LAYING

FIXING GUIDELINES

The corrosive nature of WRC (Western Red Cedar) extractives requires the use of corrosion-resistant nails or fixings particularly in applications where the timber may get wet. Iron and copper nails rapidly decompose and deteriorate, leaving holes in the timber where the nails used to be after only 1-2 years, the timber may also stain. Where there are lead or other metal flashings, care should be taken to avoid contact between the cedar and the metal. It is recommended that bituminous paint is applied as an effective barrier, or that GRP or other inert valleys or flashings are used.

When used as vertical cladding, to prevent cladding coming into direct contact with porous or wetted surfaces, Marley recommend use of either a damp proof membrane or flashing, or leaving a sufficient gap. In all cases, a gap of 150-200mm should be left below the bottom of the cladding and ground level.

The cedar should always be kept clear of any flashings below, by at least 10mm. The top edges should also be well protected.

Projecting roofs and overhangs – these provide protection to cladding and joinery products during service and result in the product being only partly exposed to the elements. This can result in uneven appearance.

Care must be taken with cedar as it has a high tannin content. Any runoff water may cause a build up of a brown coating on the surface of any metal detailing or flashings. Consideration must be given at the design stage to ensure water is drained away to the outside of the wall. These can be removed using oxalic acid.

Oxalic-acid-based products – these will remove extractives bleed and iron stains but are ineffective against mildew. After application of these products, the timber should be thoroughly rinsed with clean water and completely dried before re-coating.

Note the manufacturer's health and safety instructions when using this product.

Important: Do not use wire brushes or wire wool for surface cleaning or preparation.

See the TRADA External Timber Cladding Guide for full details.

WASTE DISPOSAL

WRC should be treated as softwood for on site disposal, and can be disposed of with other site softwood waste. It is suggested that recycling opportunities are explored with a responsible waste management company.

EAVES

A double course of shingles should be used as a starter course at the eaves.

The shingles should project at least 38mm beyond the eaves protection, or if a gutter is used, at least to the centre line of the gutter. They should extend 38mm over the verge or gable moulding/barge board.

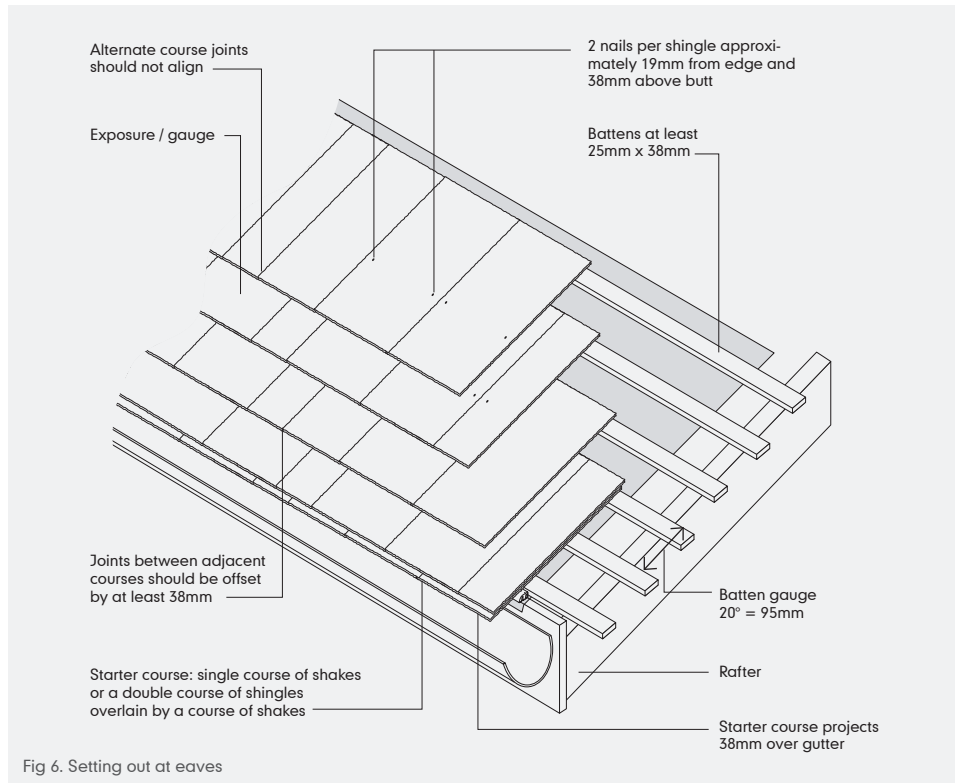

Fig 6. Setting out at eaves

RIDGES

- 1 Trim shingles to size to create shortened ridge courses. Lay along length of ridge, fixing each shingle twice.
- 2 Using pre-formed ridge units, lay along the ridge, ensuring a minimum overlap equal to the shingle gauge on the roof covering. Ridge units should be twice nailed, once either side of the ridge line (see Fig. 7).

HIPS AND RIDGES

To speed up and simplify installation, use pre-formed hips and ridges. When installing, start at each edge and work towards the middle.

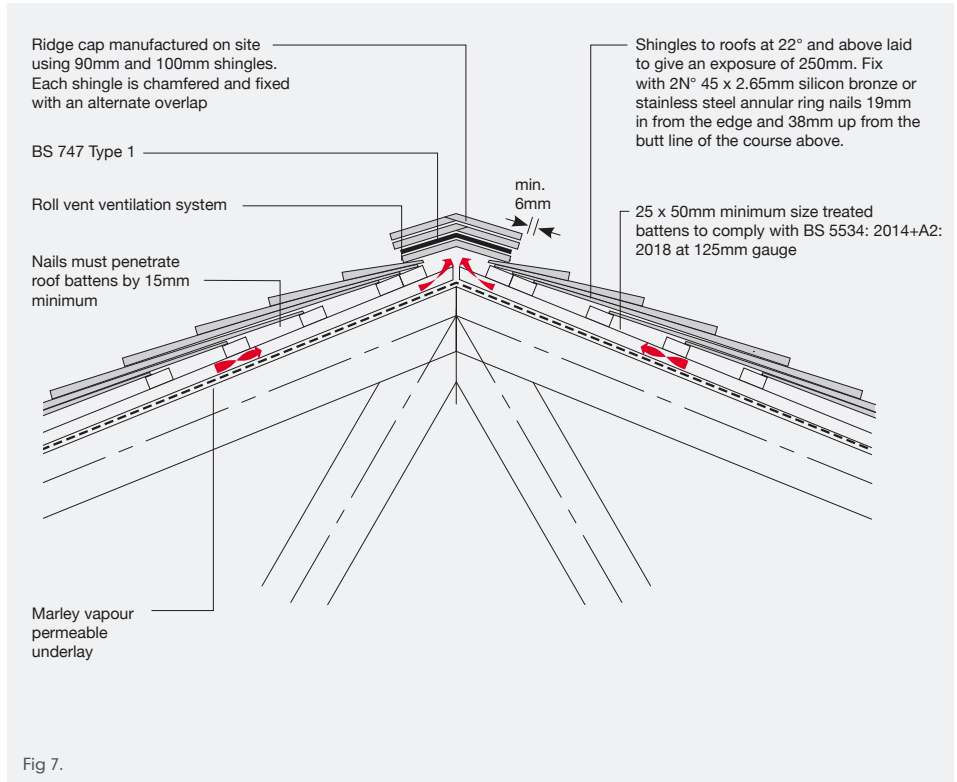

HIPS AND VALLEYS

- Hips may be formed on site by hand, or by using pre-formed cappings. A piece of felt should be used beneath each capping piece. Ventilation should be at eaves level and a Roll Vent ridge ventilator is available from Marley (see Fig. 8).
- Valleys should be code 5 lead (or as specified), should be at least 375mm in width and should be coated with patination oil or bituminous paint where contact is made with the shingles. The shingles should extend no less than 50mm over the tilt fillets on each side.

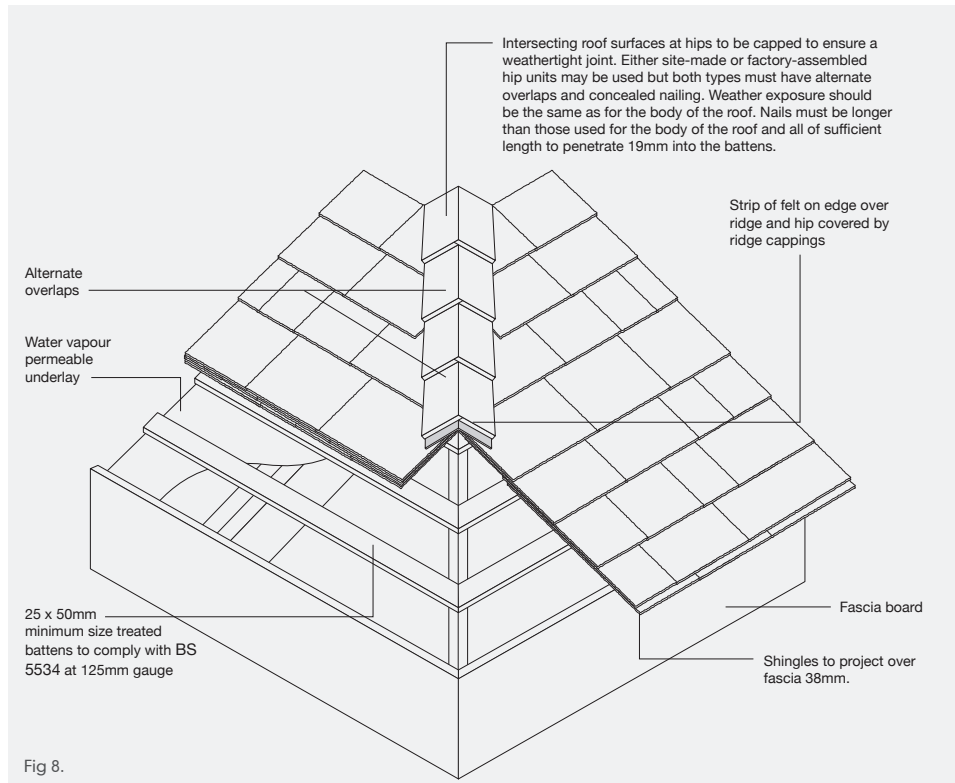

VERTICAL APPLICATIONS

Shingles are applied to walls as double-lap product (e.g. like plain tiles), as opposed to treble-lap on pitched roofs.

They are nailed directly onto battens that can be fixed to masonry or studs. A breather paper is used behind the battens. Double coursing can give attractive shadow lines. Here, shingles are applied at an extended gauge but with two courses together.

Staggered butts can also be effective. Outside corners are laced with an alternate overlap and inside mitred with a flashing behind.



COVERAGE

SHINGLES

Coverage by application table (FiveX). All quantities are exact, an allowance should be made for waste and cutting.

Use	Max. gauge	Coverage per bundle	JB Red battens per m ²	Laid weight kg/m ²
Vertical cladding				
75-90°	175mm	3.20m ²	5.7 metres	5.0 kg
Roofs				
22-74°	125mm	2.28m ²	8.0 metres	7.0 kg
14- 21°	95mm	1.73m ²	10.5 metres	9.3 kg

HIP AND RIDGE CAPPINGS

Marley supply pre-formed hips and ridges – each bundle has 36 pieces, 18 right hand and 18 left hand mitres. These are fixed alternately at the same gauge as the roof.

Use	Max. gauge	Coverage per bundle	Stainless steel nails
Roofs			
22-74°	125mm	4.5m	0.05kg per m
14- 21°	95mm	3.4m	0.065kg per m

For roofs over 45 degrees, ridge and hip cappings should be formed from shingles approximately 100mm wide

SHAKES

Shakes can be applied at a variety of gauges depending on their length and application.

Type	Vertical	Pitched
600mm and resawn gauge	209mm	190mm
	coverage 2.12m ²	1.39m ²
Battens	290mm	3.5m per m ²
		5.3m per m ²

N.B. These are exact areas and do not allow for cutting and wastage. For simple roofs allow approximately 5% but for complex roofs with significant amounts of cutting this can be up to 20%.

- 1 Double starter course – 1 bundle of shingles for every 9 linear metres (2 courses) or 1 bundle of shakes for every 7.5m
- 2 Valleys – 2 bundles for every 7.5 lin.m.
- 3 Hips and ridges – 2 bundles for every 7.5 lin.m (traditional method)

DRY FIX AND VENTILATION SYSTEMS

132 Eaves ventilation systems

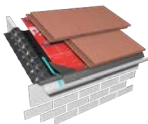

138 Verge systems



170 Hip systems

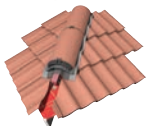

182 Valley systems

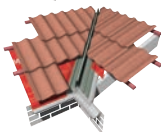

189 Ridge systems

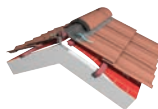

209 Abutment systems

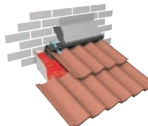

228 Roof slope systems

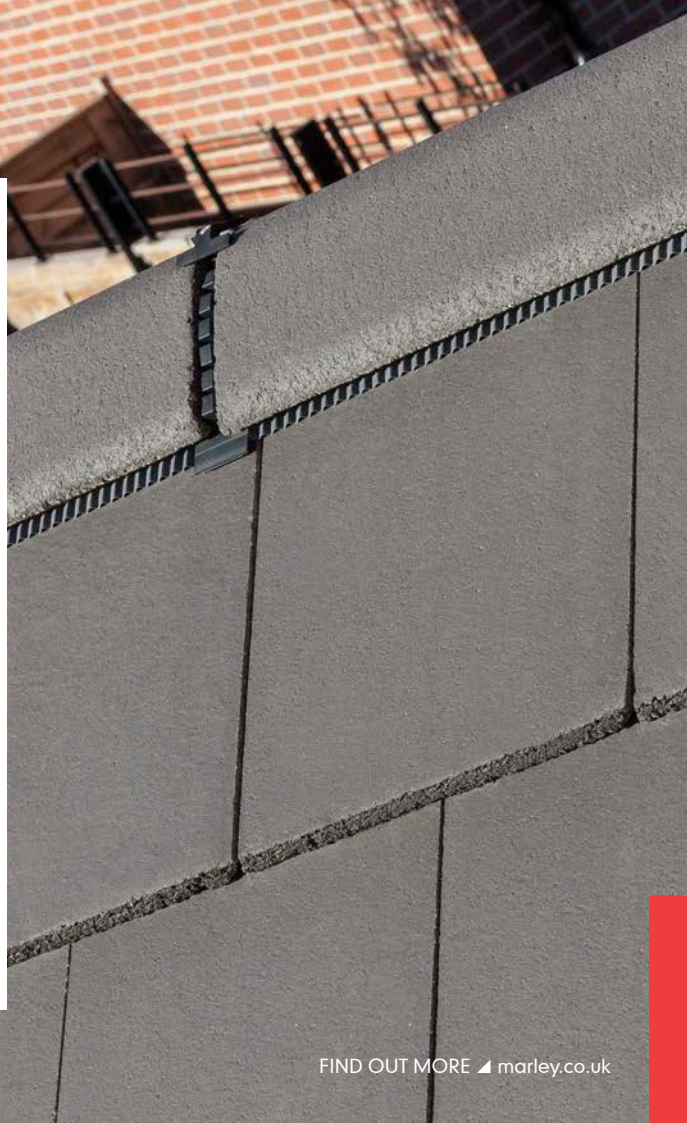

UNIVERSAL EAVES VENTS

Marley Universal Eaves Ventilation Systems are designed to provide continuous 10mm or 25mm ventilation at low level.

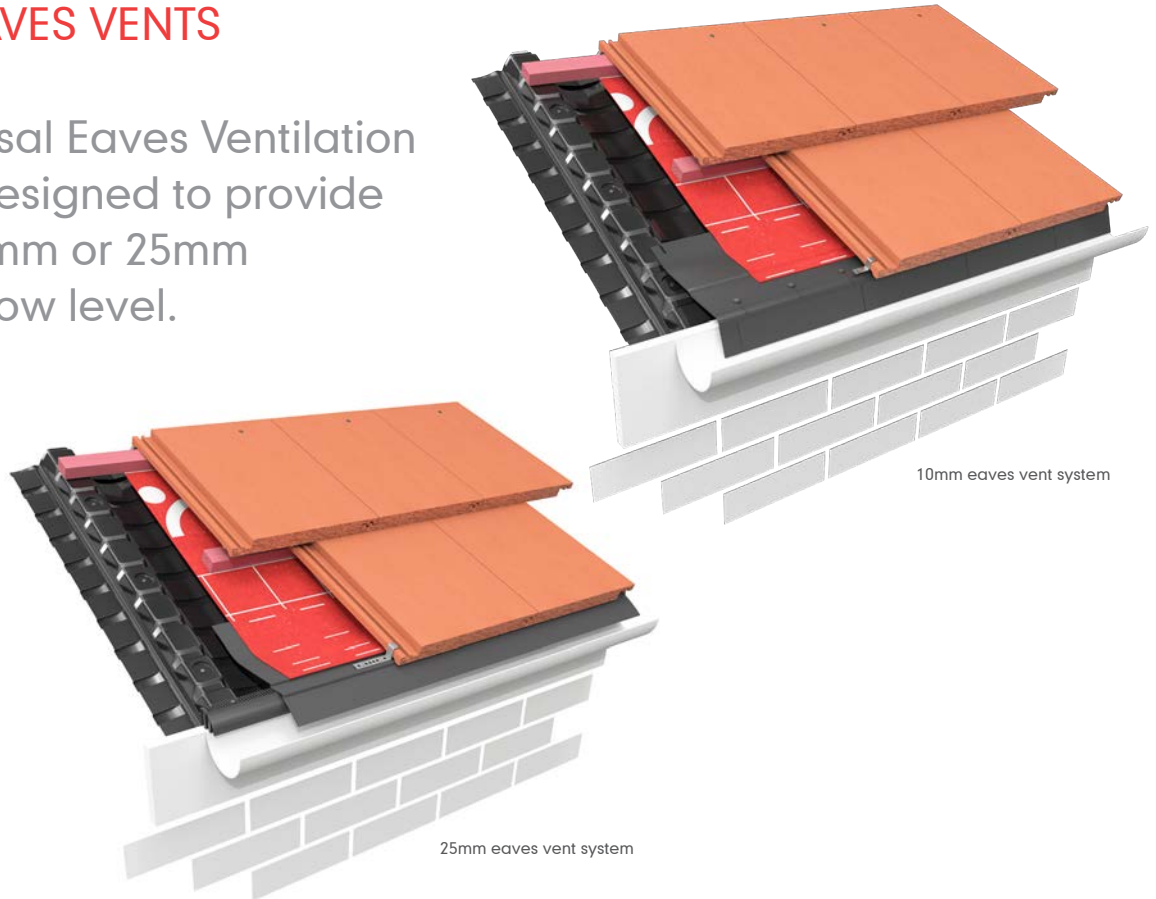

10mm eaves vent system

25mm eaves vent system

UNIVERSAL EAVES VENTS

COMPONENTS

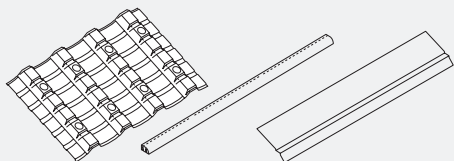

25mm eaves vent pack (6 metres)

(code 46351)

Packs contain:

- 6 No. over fascia ventilators (25mm),
- 1 No. continuous rafter roll (600mm depth),
- 10 No. felt support trays.

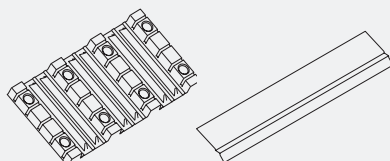

10mm eaves vent pack (6 metres)

(code 46350)

Packs contain:

- 1 No. continuous rafter roll (600mm depth),
- 10 No. ventilator/felt support trays.

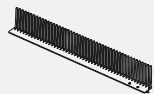

Comb filler strip
pack (6 x 1m)

(code 30425)

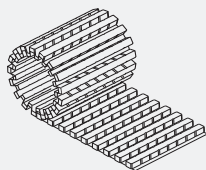

Continuous rafter
roll pack (2 x 6m)

(code 46323)

For use with profiled tiles

INSTALLATION

Before commencing work, check that fascia or tilting fillet is fixed to correct height for type of tile and rafter pitch being used, taking into account height of over fascia ventilator and comb filler strip (if required). For fascia height details, see table on page 136. Ensure that eaves course tiles are laid in the same plane.

Note: 25mm warm roof constructions (when ventilating the roof space). Dependent on gutter type, consideration should be given to maintaining a sufficient air path behind the gutter. This can be achieved using gutter spacers (available separately). Contact the Technical Advisory Service for further information.

- 1 Roll out continuous rafter roll over full length of eaves rafters so that wall plate is as close as possible to the centre of the roll.
- 2 Pull and adjust to correct rafter centres and twice nail, using 25mm long aluminium nails (Fig. 1, page 134).

UNIVERSAL EAVES VENTS

Note: The continuous rafter roll fits rafters from 400mm – 600mm centres. Ensure that insulation extends over wall plate into eaves, to prevent cold bridging. To ensure insulation does not block the ventilation path, it may be necessary to:

- Use two courses of rafter roll (additional rafter roll can be purchased separately)
- 3 Place over fascia ventilator (OFV) on top of fascia board or tilting fillet with location stop hard up against front of board.
 - 4 Nail to top of fascia or tilting fillet using 45mm x 3.35mm (10mm OFV) or 60mm x 3.35mm (25mm OFV) aluminium nails at every nail hole position (Fig 2).

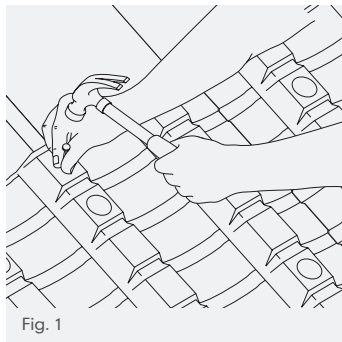

Fig. 1

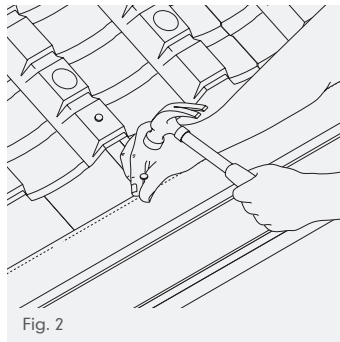

Fig. 2

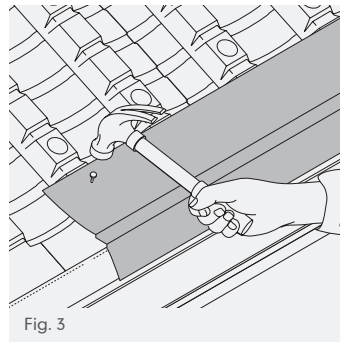

Fig. 3

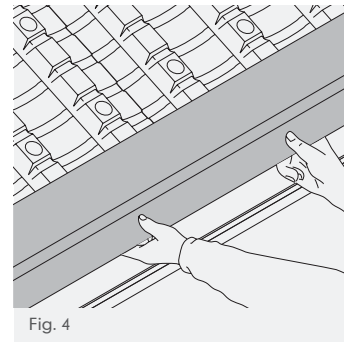

Fig. 4

Note: To assist with correct fascia height dimensions, allowance should be made for height of strip ventilator. For fascia height details, see page 136.

- 5 Place felt support trays over the over fascia vent strips and nail to rafters, using 45mm x 3.35mm (10mm OFV) or 60mm x 3.35mm (25mm OFV) nails. (Fig 3).
- 6 For 25mm kits, the underlay support tray should be laid so that the curved front edge dresses down over the fascia vent unit towards the gutter (each tray provides 600mm effective cover) (Fig 4).

For the 10mm Eaves Vent System, the ventilation element is built in to the felt support tray. Align the felt support tray with the top of the fascia board and nail in place (Fig. 5, page 135).

- 7 For 10 or 25mm systems, lay the underlay over the support tray stopped approx. 25mm from the top of the front edge of the felt support tray (Fig 6, page 135).

Note: Fixings into PVC or other non-timber fascia boards should be suitable for the material and provide sufficient pull-out resistance

UNIVERSAL EAVES VENTS

- When profiled tiles are used, fit a comb eaves filler strip to prevent ingress of birds and vermin into roof void or batten space. Locate over the felt support tray such that the eaves comb is directly above the OFV strip.
- Nail comb eaves filler strip to top of fascia board using 45mm x 3.35mm (10mm OFV) or 60mm x 3.35mm (25mm OFV) aluminium nails at every nail hole position (Fig 8).

Note: Fixings into PVC or other non-timber fascia boards should be suitable for the material and provide sufficient pull-out resistance

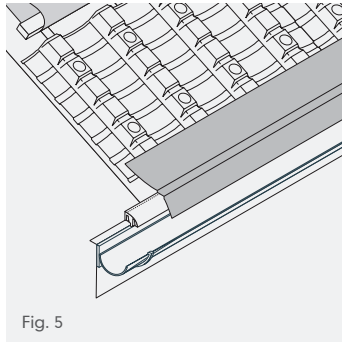

Fig. 5

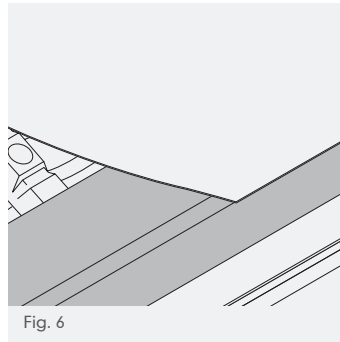

Fig. 6

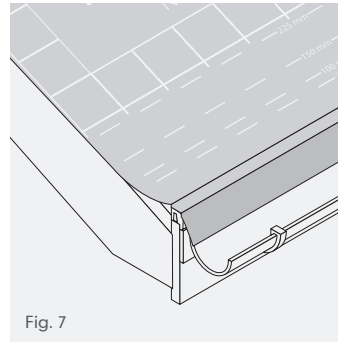

Fig. 7

- Where eaves course tiles require fixing with clips, nail appropriate eaves clip through OFV strip and into fascia board, using 45mm x 3.35mm (10mm OFV) or 60mm x 3.35mm (25mm OFV) nails.

See page 136 for eaves fascia heights.

VENTILATING THE BATTEN CAVITY USING 25mm EAVES VENT SYSTEM

- 1 Install the roofing underlay over the support tray, with the leading edge set back from exposure. (Fig 9).

Note: Timber fillets or plywood strip should be fitted at each rafter to provide support for the underlay into the gutter. Underlay support trays are not required for this type of construction. Use only suitable UV resistant membranes at the eaves.

- 2 Install counter battens on top of the underlay at each rafter. Roofing battens should then be installed as normal on top of the counter battens.
- 3 Install over fascia ventilator on top of fascia board, using 60mm x 3.35mm nails at every nail hole position.
- 4 When profiled tiles are used, install a comb filler strip.

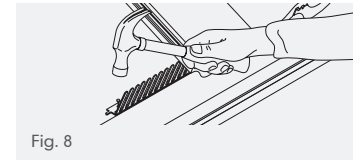

Fig. 8

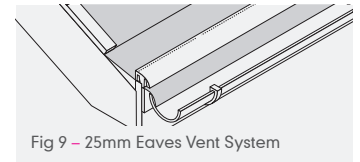

Fig 9 - 25mm Eaves Vent System

Nominal dimensions given are for guidance only and may need to be adjusted to suit site requirements by ensuring that the eaves course of tiles or slates is laid at the same pitch as the main body of the roof.

* For fascia height information regarding Mendip 12.5° (can be installed down to 12.5°), please contact our Technical Advisory Team on 01283 722330

** Please refer to manufacturers' recommendations for fibre cement and natural slate guidance figures

FASCIA HEIGHT SETTINGS (mm) FOR 10mm UNIVERSAL EAVES VENT SYSTEM (WITHOUT GUTTER SPACER)

Pitch	Gauge used mm	Headlap used mm	12.5°	15°	20°	25°	30°	35°	40°	45°	50°	55°	60°
Anglia	287	100	-	-	-	24	19	25	27	15	10	16	50
Ashmore	175	92	-	-	-	31	45	46	30	38	50	57	44
Double Roman	320	100	-	-	14	26	22	21	28	28	49	26	36
Edgemere range	320	100	-	-	27	29	21	25	28	30	26	34	36
Lincoln	270	100	35	30	31	43	39	34	39	41	30	58	52
Ludlow Major	320	100	-	-	-	25	22	18	20	32	15	17	46
Ludlow Plus	287	100	-	-	-	26	24	24	24	31	28	12	35
Mendip*	320	100	25	21	17	31	24	25	20	21	19	30	38
Modern/Duo Modern	320	100	-	-	23	28	28	40	41	33	45	40	68
Plain	100	65	-	-	-	-	-	46	36	67	38	28	34
Wessex	320	100	-	17	21	27	27	27	30	35	28	22	46
Natural & fibre cement slates**			-	-	2	2	2	2	6	6	6	6	**

FASCIA HEIGHT SETTINGS (mm) FOR 25mm UNIVERSAL EAVES VENT SYSTEM (WITHOUT GUTTER SPACER)

Pitch	Gauge used mm	Headlap used mm	12.5°	15°	20°	25°	30°	35°	40°	45°	50°	55°	60°
Anglia	287	100	-	-	-	23	21	24	30	16	38	28	39
Ashmore	175	92	-	-	-	31	43	43	29	48	53	49	44
Double Roman	320	100	-	-	4	25	22	36	26	27	25	26	38
Edgemere range	320	100	-	-	27	29	22	33	27	29	26	35	36
Lincoln	270	100	40	24	25	41	37	38	41	37	30	60	60
Ludlow Major	320	100	-	-	-	26	22	26	20	27	17	25	46
Ludlow Plus	287	100	-	-	-	26	31	23	23	27	28	13	40
Mendip*	320	100	12	15	12	25	25	26	30	33	49	20	38
Modern/Duo Modern	320	100	-	-	12	28	28	40	38	42	44	41	63
Plain	100	65	-	-	-	-	-	46	34	63	38	27	32
Wessex	320	100	-	-	27	27	26	27	31	33	33	19	46
Natural & fibre cement slates**			-	-	2	2	2	2	6	6	6	6	**

FASCIA HEIGHT SETTINGS (mm) WITHOUT VENTS OR TRAYS

Pitch	Gauge used mm	Headlap used mm	12.5°	15°	20°	25°	30°	35°	40°	45°	50°	55°	60°
Anglia	287	100	-	-	-	53	60	60	70	69	78	73	89
Ashmore	175	92	-	-	-	51	69	62	67	72	72	73	67
Double Roman	320	100	-	-	39	41	49	42	46	41	43	45	92
Edgemere range	320	100	-	-	47	47	52	51	46	45	59	51	76
Lincoln	270	100	57	53	54	50	56	55	60	58	64	63	76
Ludlow Major	320	100	-	-	-	46	49	48	54	61	56	84	95
Ludlow Plus	287	100	-	-	-	44	52	51	49	49	62	54	100
Mendip*	320	100	42	42	41	41	46	59	49	52	54	80	92
Modern/Duo Modern	320	100	-	-	41	46	48	55	58	52	61	80	64
Plain	100	65	-	-	-	-	-	49	59	64	63	74	61
Wessex	320	100	-	42	14	47	56	51	57	41	64	79	82
Natural & fibre cement slates**			-	-	2	2	2	2	6	6	6	6	**

UNIVERSAL EAVES CLIP

The variable height of the Universal Eaves Clip not only gives the possibility to adjust the height of the clip, but has also the flexibility to be adjusted to the specific roof pitch.

The Zial® (Zinc-Aluminium) coated clip has a flexible strip with the pre-punched fixing holes that can be easily bent to the required height during installation. The adjustable end rotates to the pitch of the roof and securely grips the underlock and sidelock of various roof tiles.

100 per box, nails sold separately, product code 30279, suitable to use with the following Marley concrete tiles and clay tiles.

COMPATIBILITY

- Anglia
- Double Roman
- Eden
- Edgemere range
- Lincoln
- Ludlow Plus and Ludlow Major
- Mendip and Mendip 12.5
- Modern and Duo Modern

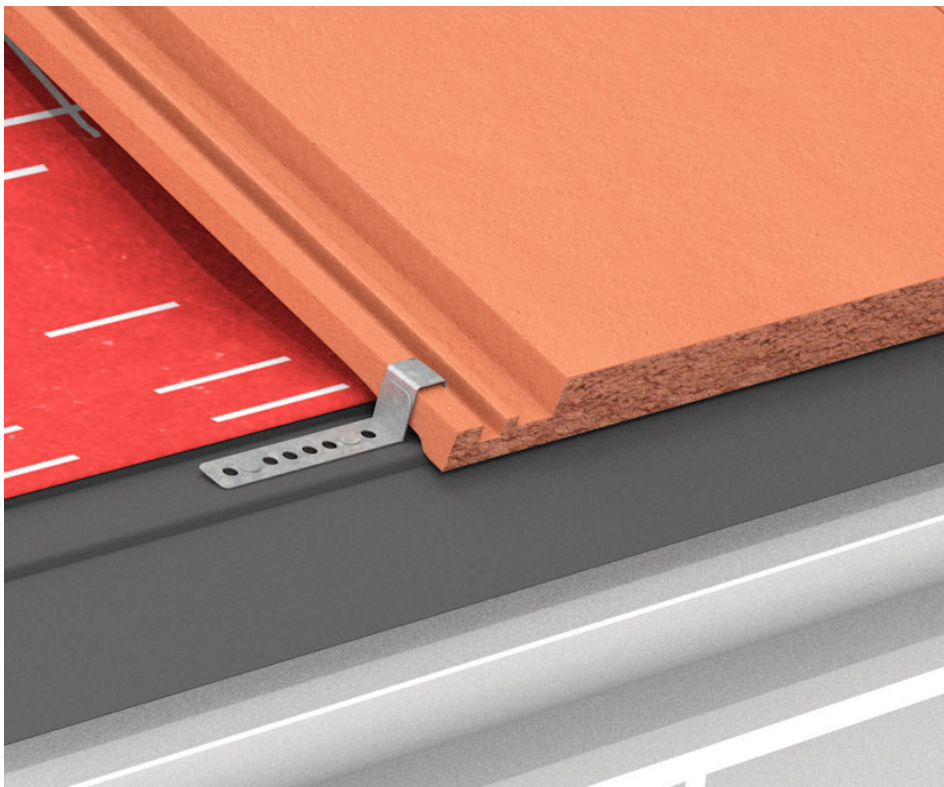

UNIVERSAL DRY VERGE SYSTEM

Marley's Universal Dry Verge system has been designed to make verge detailing secure, BS 5534-compliant and elegantly simple*. The system is faster and easier to install, more weathertight, durable and secure than ever.

Note: Universal dry verge acts as a single mechanical fixing in accordance with the latest version of BS 5534.



UNIVERSAL DRY VERGE SYSTEM

COMPONENTS

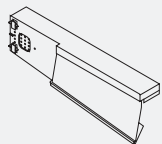

Universal dry
verge unit
(LH code 391,
RH code 392)



Segmental ridge
end cap
(code 395)



Modern ridge
end cap
(code 394)



Universal batten
end clip
(code 30214)

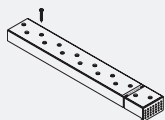

Dry verge
refurbishment
fixing kit
(code 53580)
24 No. batten
extension units



Segmental
mono-ridge
end cap and
wire hook
(LH code 427,
RH code 428)



Modern
mono-ridge
end cap and
wire hook
(LH code 408,
RH code 409)

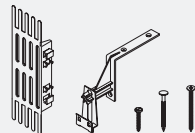

Universal dry verge
starter unit
(code 53931)*

Kit contains:
2 No. Bracket assemblies
2 No. Plastic filler units
10 No. 30mm stainless
steel screws
4 No. 50mm stainless
steel screws

* Sold separately

INSTALLATION

- 1 Set out eaves course of roof tiles in normal manner, ensuring that, wherever possible, full tiles complete verge-overhang or that highest section of tile profile is cut to finish at edge. Finish the underlay flush with the outer edge of the bargeboard or brickwork.
- 2 Saw tiling battens off square to overhang bargeboard or brickwork by 50mm and coat the cut ends with a suitable timber treatment (Fig. 1). Install universal batten end clips to the ends of the battens in accordance with BS8612.

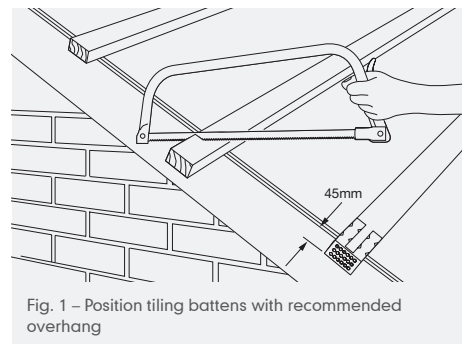

Fig. 1 – Position tiling battens with recommended overhang

UNIVERSAL DRY VERGE SYSTEM

3 Position top course battens to ensure the ridge tiles overlap the tiles by no less than 75mm.

4 Securing the starter bracket assembly:

(a) Directly to fascia board where there is no requirement for an eaves ventilator strip:

Secure the starter bracket assembly directly onto the corner of the fascia using three of the 30mm screws provided (Fig. 2).

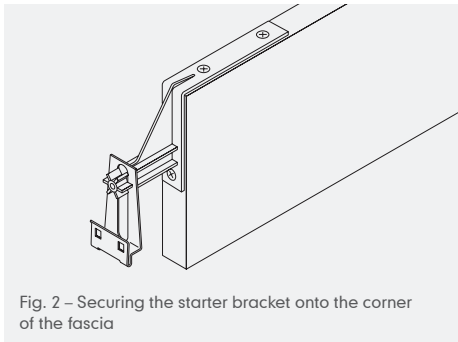

Fig. 2 – Securing the starter bracket onto the corner of the fascia

(b) Directly into fascia strip ventilator:

Using two of the 50mm screws provided, secure the starter bracket assembly through the top edge of the fascia ventilator strip and into the fascia board underneath. Be careful not to overtighten. Using one of the 30mm screws provided, secure the starter bracket through the side fixing hole (Fig. 3).

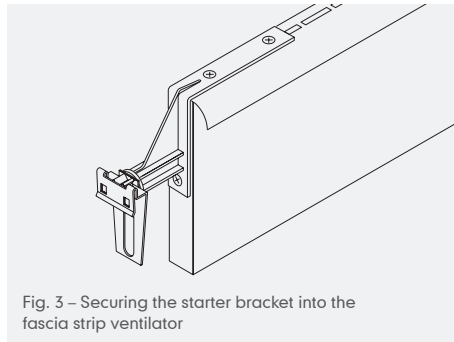

Fig. 3 – Securing the starter bracket into the fascia strip ventilator

(c) Directly into brickwork:

Using a pair of snips, or similar cutting device, remove the top of the starter bracket assembly at 90° corner, leaving side fixing and the metal spring fixing clip. Drill, plug and secure side assembly into brickwork using one of the 30mm screws provided (Fig. 4).

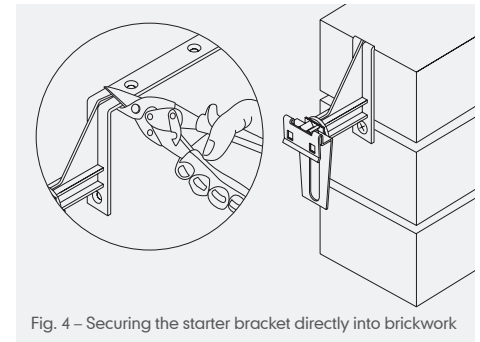

Fig. 4 – Securing the starter bracket directly into brickwork

UNIVERSAL DRY VERGE SYSTEM

- Slide the plastic filler piece onto the internal rails of the dry verge. The filler piece prevents the ingress of birds and insects and will position onto the two middle rails. Engage and slide the filler piece until it clicks into place, approximately half way down the internal rails. Please note that the filler will only engage if it is the correct way round, as illustrated in Fig. 5.
- Push the verge unit up so that the front flange meets flush with the leading edge of the tile (Fig. 6). Fix the verge unit to the tiling batten by means of mechanical

engagement using the Marley batten end clip using the appropriate hole (nearest to the centre of the tiling batten).

- Once the first unit is mechanically fixed into the batten end, secure the front edge of the dry verge with the metal spring clip by pushing it on until it cannot go any further.
- A gentle hammer tap may be required to assist with this. The spring clip achieves a secure fix at one end by clamping (when engaged fully) to the front of the dry verge (Fig. 7).

The other end, when engaged fully will slot through the first and largest slot in the plastic filler unit.

- When installing the dry verge in conjunction with medium format (15" x 9" - for instance, Ludlow Plus) tiles the leading flange should be bent out slightly to allow the verge to engage at a lower level and accommodate tiles with a thinner leading edge. The dry verge flange will need to be bent out as shown in Fig. 8.
- Successive dry verge units are interlocked

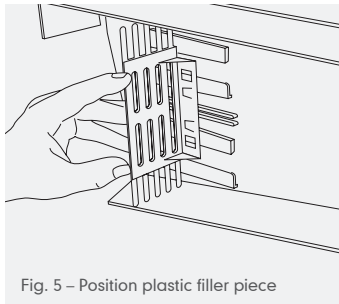

Fig. 5 – Position plastic filler piece

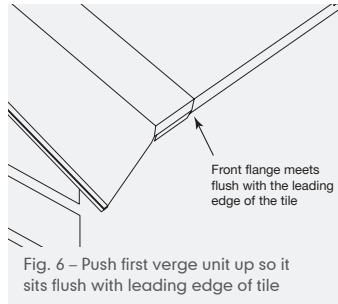

Fig. 6 – Push first verge unit up so it sits flush with leading edge of tile

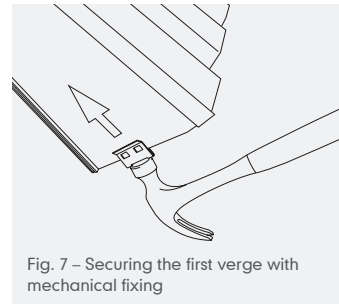

Fig. 7 – Securing the first verge with mechanical fixing

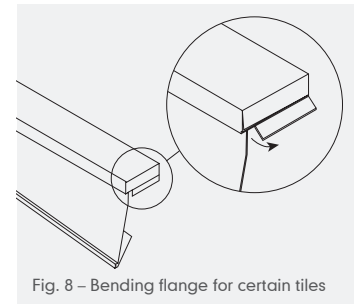

Fig. 8 – Bending flange for certain tiles

UNIVERSAL DRY VERGE SYSTEM

together by sliding upwards against unit below, ensuring that lugs on outside of verge unit fit into internal locating slots (Fig. 9).

IMPORTANT: Verge units can be slid together at different height positions dependent on the roof tile profile and thickness of the leading edge.

Therefore it is important, when installing with medium format and thin leading edge tiles, that the leading flange is bent out to ensure that the verge drops down and engages with the tile below at the correct height.

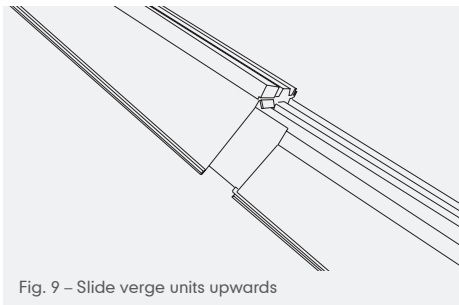

Fig. 9 – Slide verge units upwards

All verge tiles should be mechanically fixed in accordance with BS 5534 in addition to the use of the Universal dry verge units, i.e. by nailing, clipping or screwing as appropriate.

INSTALLATION WITH MEDIUM FORMAT INTERLOCKING PANTILES

11 When using medium format tiles, verge unit distortion can occur when the units are slid into position beneath the next tile course above. This distortion can be eliminated by making a small cut (Fig. 10) along the witness line, as shown.

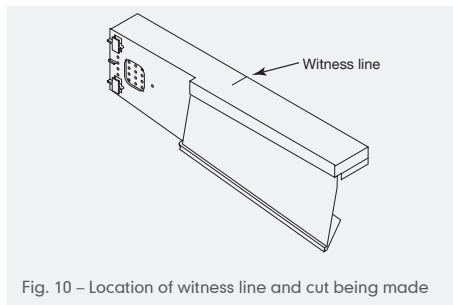

Fig. 10 – Location of witness line and cut being made

USE WITH DRY RIDGE SYSTEM BATTENS

12 At apex of roof, where battens are located, retain top course dry verge unit by securing a 30mm long screw (supplied in the fixing kit) into second series of holes in verge unit and locate it behind nib section of dry ridge batten (Fig. 11).

13 If required, trim flange of ridge and cap to fit between top course verge units (Fig. 12, page 143). Screw ridge end cap to end of dry ridge batten by locating 30mm stainless steel screws into end of circular beads on upper flange (Fig. 13, page 143).

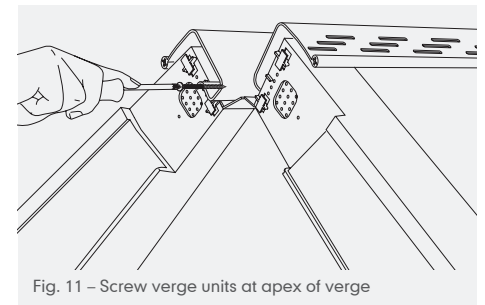

Fig. 11 – Screw verge units at apex of verge

UNIVERSAL DRY VERGE SYSTEM

USING BEDDED RIDGES AND RIDGEFAST DRY RIDGE

- 14 Screw ridge end cap through top course verge unit, to end of top course tiling batten. Locate 30mm stainless steel screw (provided) through lower, partly formed fixing holes (Fig. 13).
- 15 If required, trim flange of ridge end cap to fit between top course verge units. (Fig. 12). Top course verge unit is secured to end of top course tiling batten in normal manner.

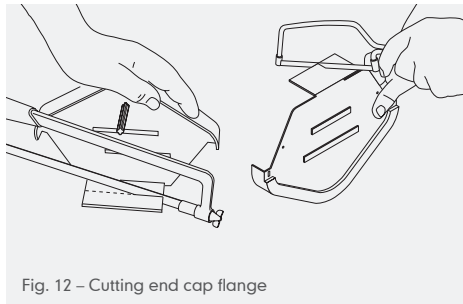

Fig. 12 – Cutting end cap flange

MONO-RIDGE END CAP FIXING WIRE

- 16 Construct dry verge units as before up to the roof apex.
- 17 Prior to fixing the gable end mono-ridge tile, push the security wire through the outside face of the mono-ridge tile (using the same fixing hole for screwing the mono-ridge tile to the wall) and bend through 90° (Fig. 14).
- 18 Feed the free end of the wire through the hole in the mono-ridge end cap.

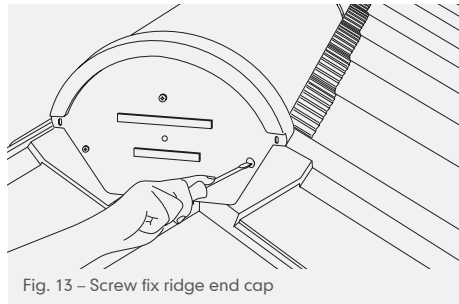

Fig. 13 – Screw fix ridge end cap

Push the end cap tightly against the mono-ridge tile and bend the wire protruding through the end cap downwards flush with the vertical face.

- 19 This assembly can now be placed into position, securing the mono-ridge tile with the stainless steel screws provided. The leading edge of the end cap is secured to the dry ridge batten section (or end of top tiling batten for mortar bedded ridges) using a 30mm screw (supplied in the fixing kit).

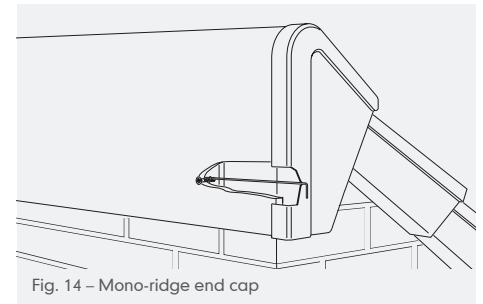
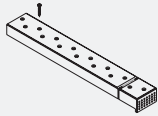

Fig. 14 – Mono-ridge end cap

UNIVERSAL DRY VERGE REFURBISHMENT KIT

COMPONENTS



Dry verge refurbishment fixing kit

(code 53580)

24 No. batten extension units
(suitable for 38mm x 25mm battens only)

The dry verge refurbishment kit facilitates the application of Universal dry verge systems to existing tiled roofs, where mortar bedded verges require replacement.

INSTALLATION

- 1 Rake out and carefully remove all mortar bedding at verge and ridge ends.
- 2 Remove one row of roof tiles and end ridge tiles immediately adjacent to verge.
- 3 Remove any mortar adhering to these tiles in the area where they engage on tiling batten and at headlap.
- 4 Remove undercloak (fibre cement strip or tile) and check that visible parts of tiling battens are in good condition.
- 5 Fit batten extension units onto the ends of tiling battens, using line moulded into top of unit as guide, so that they should overhang gable end by 45-50mm. Use 3 x No. 6 20mm stainless steel screws, ensuring 'ridge side' face is in contact with back face of batten.
- 6 Commence installation of the dry verge units in accordance with the fixing instructions (product codes 53930 or 53830), by aligning an appropriate hole in verge unit with a suitable hole in the end flange of batten extension unit.
- 7 Secure each verge unit using No. 6 x 20mm stainless steel screws.
- 8 Subsequent dry verge units can be fixed either during tiling operation or after tiles have been laid.
- 9 End ridge tiles should be re-bedded and secured by ridge end cap.

Note: If any battens are damaged or rotten, cut back to good timber prior to fixing batten extension units. Where extensive damage has occurred, replace affected batten by a new section. Fixing flange of batten extension unit can be cut off to leave a continuous U-shaped channel and can be used as a bridging piece between new and old batten ends, avoiding the need to remove additional roof tiles.

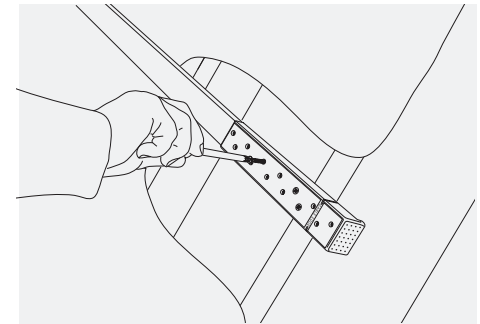

Fig. 19 – Fit extension using line moulded into unit top unit as guide

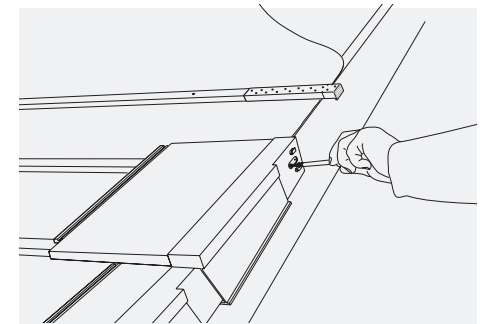

Fig. 20 – Commence installation of dry verge units in normal manner

EDGEMERE DRY VERGE SYSTEM

The Edgemere dry verge system provides a strong, weathertight and maintenance-free verge. Individual verge units retain the stepped appearance of a traditional mortar bedded verge while mechanically fixing the verge tiles.

Note: Edgemere dry verge acts as a single mechanical fixing in accordance with the latest version of BS 5534.



BS 8612
COMPLIANT

EDGEMERE DRY VERGE SYSTEM

COMPONENTS

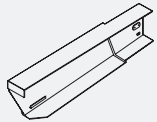

Edgemere dry verge unit

(LH code 381, RH code 382)



Edgemere ridge end cap

(code 384)

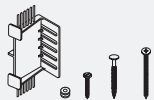

Edgemere dry verge starter unit*

(code 53830)

Kit contains:
2 No. 25mm x 8g stainless steel screws, 2 No. starter inserts, 2 No. 30mm x 8g stainless steel, pozidrive headed screws, 2 No. nylon spacers



Modern mono-ridge end cap and wire hook

(code 395)

INSTALLATION

- 1 Set out eaves course of roof tiles in normal manner, ensuring that wherever possible full tiles and half tiles complete verge overhangs.
- 2 Saw tiling battens off square to overhang bargeboard or brickwork by 45mm and treat cut ends with a suitable timber treatment. Nail or screw battens within 500mm of ends (Fig. 1).
- 3 Position top course battens to ensure the ridge tiles overlap the tiles by no less than 75mm
- 4 Place first eaves roof tile in position overhanging the verge.
- 5 Slide starter insert into internal fixing channels of dry verge unit, and position assembly over eaves roof tile into position at which it will be fixed (Fig. 2, page 147).
- 6 Mark location of a suitable fixing position against gable wall or bargeboard through one of the slots in starter insert.
- 7 Remove roof tile and dry verge unit and slide out starter insert.

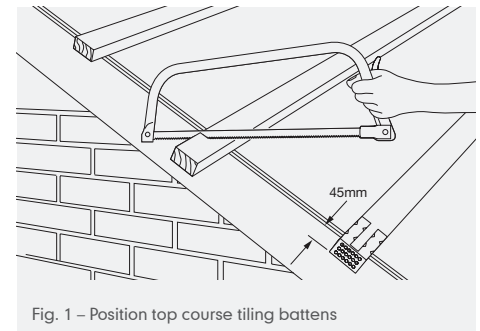
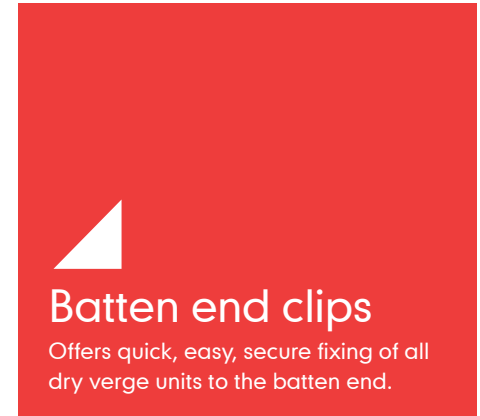

Fig. 1 – Position top course tiling battens

EDGEMERE DRY VERGE SYSTEM

- 8 Once removed, relocate starter insert in marked position and mechanically fix through spacer supplied, trapping between starter insert and gable wall or bargeboard (Fig. 3).

Note: Where brickwork is encountered, starter inserts should be drilled and plugged to ensure secure fixing.

For non-standard eaves/verge constructions, contact the Technical Advisory Service for advice on fixing.

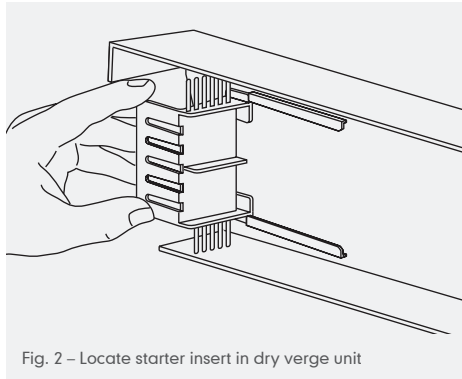

Fig. 2 – Locate starter insert in dry verge unit

- 9 Engage eaves course dry verge unit with lugs of the starter insert.

- 10 Fix the verge unit to the tiling batten through the batten end clips with the ring-shank nails provided (Fig. 4)

Note: Ensure that nail head fits flush into moulded recess around the nail hole and does not interfere with fitting of next verge unit.

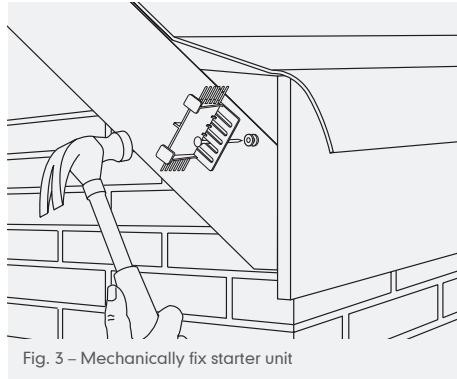

Fig. 3 – Mechanically fix starter unit

- 11 Fix subsequent dry verge units as tiling proceeds, or in a single operation after completion of roof tiling. Ensure that verge tiles are fully inserted into verge units.

- 12 Successive dry verge units are interlocked together by sliding upwards against unit below, ensuring that lugs on outside of verge unit fit into internal locating slots (Fig. 5, page 148).

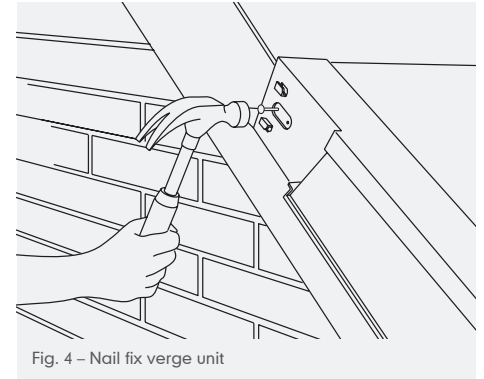

Fig. 4 – Nail fix verge unit

EDGEMERE DRY VERGE SYSTEM

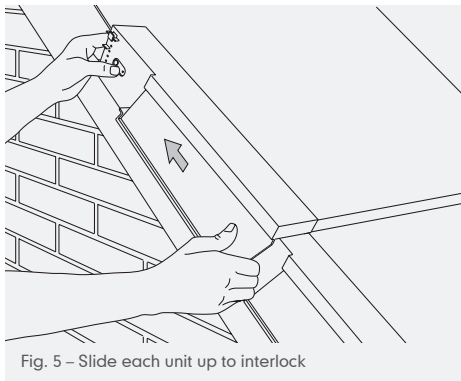

Fig. 5 – Slide each unit up to interlock

IMPORTANT: All verge tiles should be mechanically fixed in accordance with BS 5534 in addition to the use of the Edgemere dry verge units, i.e. by nailing, clipping or screwing as appropriate.

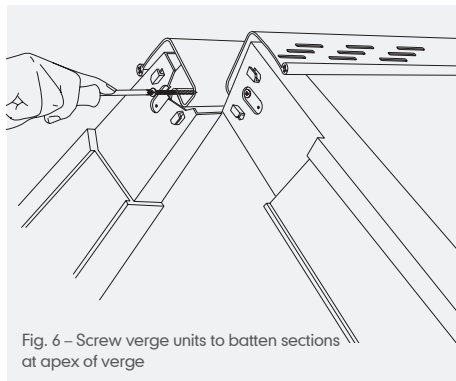

Fig. 6 – Screw verge units to batten sections at apex of verge

USE WITH DRY RIDGE SYSTEM BATTENS

13 At apex of roof, where battens sections are located, retain top course dry verge unit by securing a 30mm long pozidrive head screw (supplied) into second series of holes in verge unit and locate it behind nib section of dry ridge batten (Fig. 6).

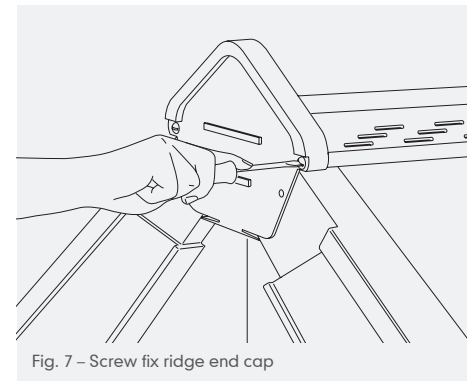

Fig. 7 – Screw fix ridge end cap

14 If required, trim flange of ridge end cap to fit between top course verge units (Fig. 9, page 149). Screw ridge end cap to end of dry ridge batten locating 25mm x 8g stainless steel screws into end of circular beads on upper flange (Fig. 7).

EDGEMERE DRY VERGE SYSTEM

USE WITH BEDDED RIDGES AND RIDGEFAST DRY RIDGE

- 15 Top course verge unit is secured to end of top course tiling batten in normal manner.
- 16 If required, trim flange of ridge end cap to fit between top course verge units (Fig. 9). Screw ridge end cap to top course verge unit, locating stainless steel screws through lower, partly formed fixing holes (Fig. 8).

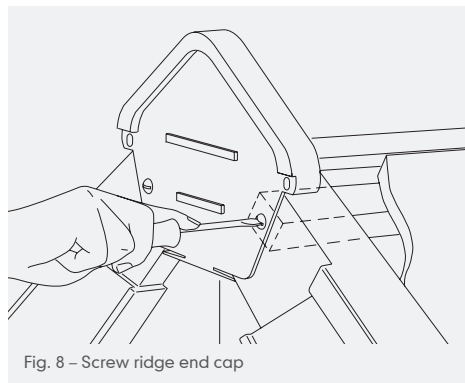

Fig. 8 – Screw ridge end cap

MONO-RIDGE END CAP FIXING WIRE

- 17 Construct dry verge units as before up to the roof apex.
- 18 Prior to fixing the gable end mono-ridge tile push the security wire through the outside face of the mono-ridge tile (using the same fixing hole for screwing the mono-ridge tile to the wall) and bend through 90° (Fig. 10).
- 19 Feed the free end of the wire through the hole in the mono-ridge end cap. Push the

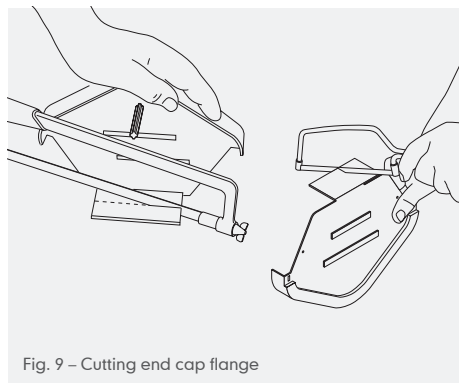

Fig. 9 – Cutting end cap flange

end cap tightly against the mono-ridge tile and bend the wire protruding through the end cap downwards flush with the vertical face.

- 20 This assembly can now be placed into position, securing the mono-ridge tile with the stainless steel screws provided. The leading edge of the end cap is secured to the dry ridge batten section (or end of top tiling batten for mortar bedded ridges) using a 25mm x 8g stainless steel screw supplied in the fixing kit.

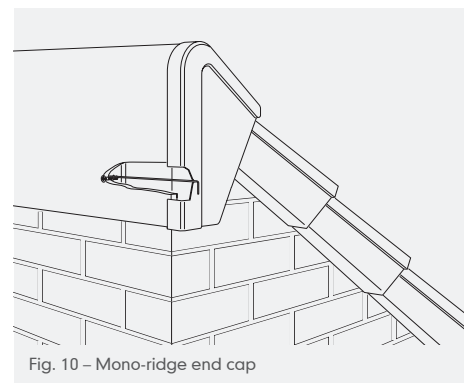

Fig. 10 – Mono-ridge end cap

ASHMORE DRY VERGE SYSTEM

This dry verge provides a strong, mechanically fixed, weathertight verge that meets the requirements of BS 5534 and BS 8612. The system is fast and simple to install and offers a sleek, maintenance-free verge solution.

Note: Ashmore dry verge acts as a single mechanical fixing in accordance with the latest version of BS 5534.



ASHMORE DRY VERGE SYSTEM

COMPONENTS

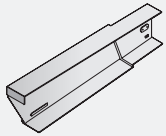

Ashmore dry verge unit

(LH Codes:
Grey 39611,
Brown 39613,
Terracotta 39614)

(RH Codes:
Grey 39711,
Brown 39713,
Terracotta 39714)



Ashmore segmental ridge end cap

(code 398*)



Batten end clip

(code 30214)

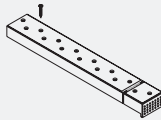

Dry verge refurbishment fixing kit

(code 53580)

24 No. batten extension units

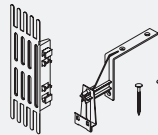

Ashmore dry verge starter unit

(code 39900)

Sold separately.

Kits contain:

- 2 No. Bracket assemblies,
- 2 No. Plastic filler units,
- 10 No. 30mm stainless steel screws,
- 4 No. 50mm stainless steel screws.

* Suffix with colour code 01 Grey, 03 Brown, 04 Terracotta

INSTALLATION

- 1 Set out eaves course of roof tiles in normal manner, ensuring that, wherever possible, full tiles complete verge-overhang or that highest section of tile profile is cut to finish at edge.

Finish the underlay flush with the outer edge of the bargeboard or brickwork.

- 2 Saw tiling battens off square to overhang bargeboard or brickwork by 45mm, coat the cut ends with a suitable timber treatment and nail (Fig. 1).
- 3 Position top course battens to ensure the ridge tiles overlap the tiles by no less than 75mm.

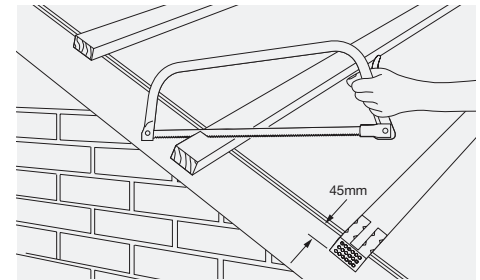

Fig. 1 – Position top course tiling battens

ASHMORE DRY VERGE SYSTEM

4 Securing the starter bracket assembly:

(a) Directly to fascia board where there is no requirement for an eaves ventilator strip:

Secure the starter bracket assembly directly onto the corner of the fascia using three of the 30mm screws provided (Fig. 2).

(b) Directly into fascia strip ventilator:

Using two of the 50mm screws provided, secure the starter bracket assembly through the top edge of the fascia

ventilator strip and into the fascia board underneath. Be careful not to overtighten. Using one of the 30mm screws provided, secure the starter bracket through the side fixing hole (Fig. 3).

(c) Directly into brickwork:

Using a pair of snips, or similar cutting device, remove the top of the starter bracket assembly at 90° corner, leaving side fixing and the metal spring fixing clip. Drill, plug and secure side assembly into brickwork using one of the 30mm screws provided (Fig. 4).

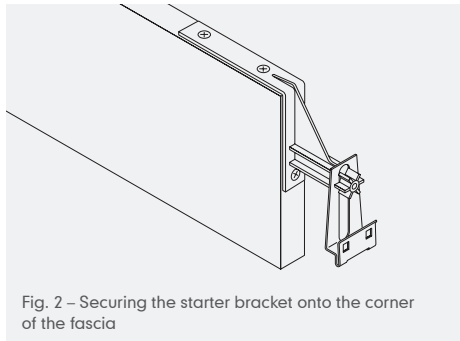

Fig. 2 – Securing the starter bracket onto the corner of the fascia

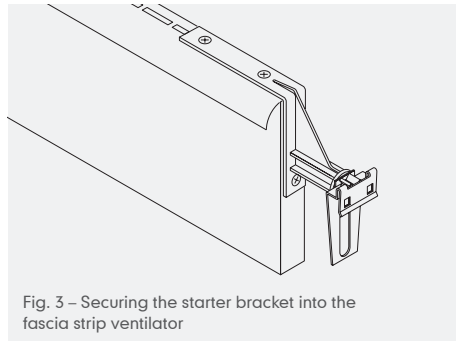

Fig. 3 – Securing the starter bracket into the fascia strip ventilator

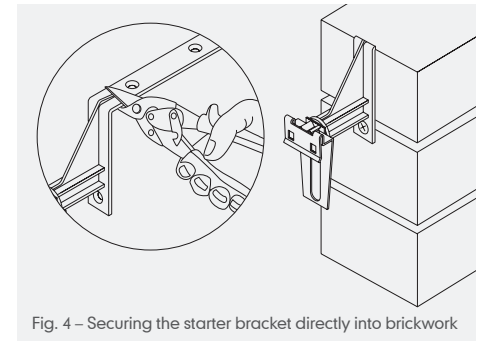

Fig. 4 – Securing the starter bracket directly into brickwork

ASHMORE DRY VERGE SYSTEM

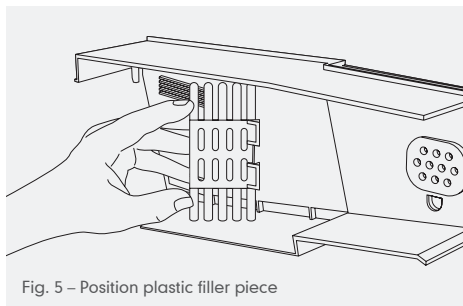

Fig. 5 – Position plastic filler piece

- 5 The filler piece prevents the ingress of birds and insects. Insert the plastic filler piece into the locating upstands on the rear of the dry verge as illustrated in Figs. 5 and 6.
- 6 Angle the filler piece at 45° and firmly push into the central upstand. Rotate to the vertical position to locate/click into the outer upstands as illustrated in Fig. 7.
- 7 Once the first unit is mechanically fixed into the batten-end, secure the front edge of the dry verge with the metal spring-clip by pushing it on until it cannot go any further.

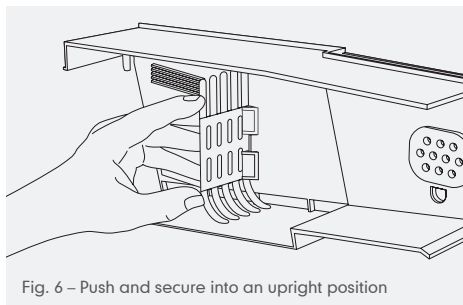

Fig. 6 – Push and secure into an upright position

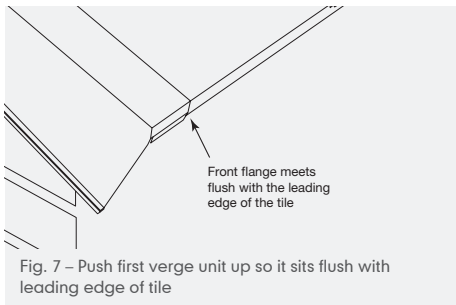

Fig. 7 – Push first verge unit up so it sits flush with leading edge of tile

- 8 A gentle hammer tap may be required to assist with this. The spring clip achieves a secure fix at one end by clamping (when engaged fully) to the front of the dry verge (Fig. 8).

The other end, when engaged fully will slot through the first and largest slot in the plastic filler unit.

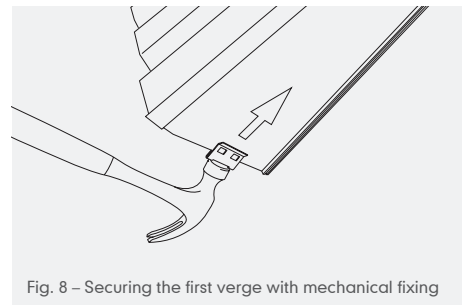

Fig. 8 – Securing the first verge with mechanical fixing

ASHMORE DRY VERGE SYSTEM

- 9 Successive dry verge units are interlocked together by sliding upwards against unit below, ensuring that lugs on outside of verge unit fit into internal locating slots (Fig. 9).

IMPORTANT: Verge units can be slid together at different height positions dependent on the roof tile profile and thickness of the leading edge.

Therefore it is important, when installing with medium format and thin leading edge tiles, that the leading flange is bent out to ensure that the verge drops down and engages with the tile below at the correct height.

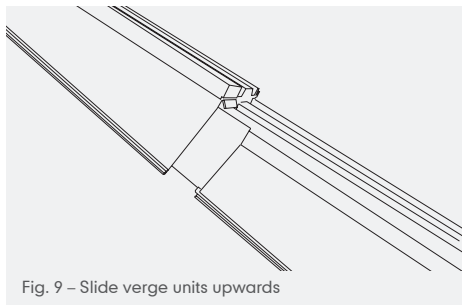

Fig. 9 – Slide verge units upwards

All verge tiles should be mechanically fixed in accordance with BS 5534 in addition to the use of the Universal dry verge units, i.e. by nailing, clipping or screwing as appropriate.

INSTALLATION WITH MEDIUM FORMAT INTERLOCKING PANTILES

- 10 When using medium format tiles, verge unit distortion can occur when the units are slid into position beneath the next tile course above. This distortion can be eliminated by making a small cut (Fig. 10) along the witness line, as shown.

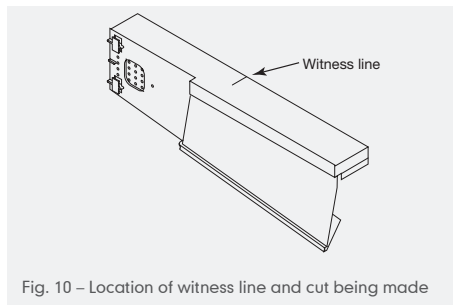

Fig. 10 – Location of witness line and cut being made

USE WITH DRY RIDGE SYSTEM BATTENS

- 11 At apex of roof, where battens are located, retain top course dry verge unit by securing a 30mm long screw (supplied in the fixing kit) into second series of holes in verge unit and locate it behind nib section of dry ridge batten (Fig. 11).
- 12 If required, trim flange of ridge and cap to fit between top course verge units (Fig. 12, page 155). Screw ridge end cap to end of dry ridge batten by locating 30mm stainless steel screws into end of circular beads on upper flange (Fig. 13, page 155).

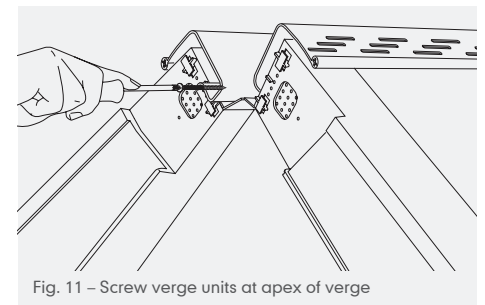

Fig. 11 – Screw verge units at apex of verge

ASHMORE DRY VERGE SYSTEM

USING BEDDED RIDGES AND RIDGEFAST DRY RIDGE

- 13 Screw ridge end cap through top course verge unit, to end of top course tiling batten. Locate 30mm stainless steel screw (provided) through lower, partly formed fixing holes (Fig. 12).
- 14 If required, trim flange of ridge end cap to fit between top course verge units. (Fig. 13). Top course verge unit is secured to end of top course tiling batten in normal manner.

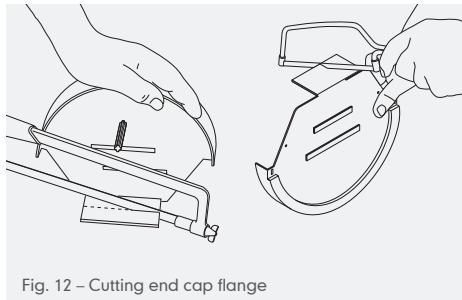

Fig. 12 – Cutting end cap flange

MONO-RIDGE END CAP FIXING WIRE

- 15 Construct dry verge units as before up to the roof apex.
- 16 Prior to fixing the gable end mono-ridge tile, push the security wire through the outside face of the mono-ridge tile (using the same fixing hole for screwing the mono-ridge tile to the wall) and bend through 90° (Fig. 14).
- 17 Feed the free end of the wire through the hole in the mono-ridge end cap. Push the

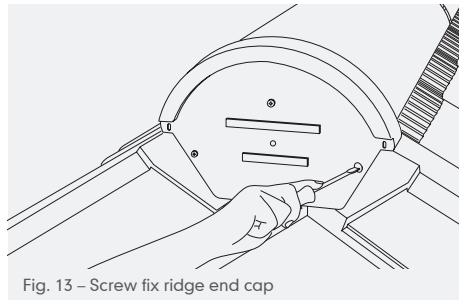

Fig. 13 – Screw fix ridge end cap

end cap tightly against the mono-ridge tile and bend the wire protruding through the end cap downwards flush with the vertical face.

- 18 This assembly can now be placed into position, securing the mono-ridge tile with the stainless steel screws provided. The leading edge of the end cap is secured to the dry ridge batten section (or end of top tiling batten for mortar bedded ridges) using a 30mm screw (supplied in the fixing kit).

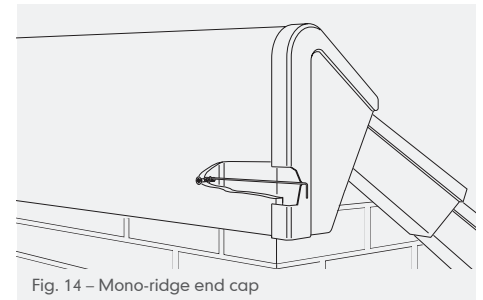

Fig. 14 – Mono-ridge end cap

CONTINUOUS DRY VERGE

For use with Ashmore and Edgemere interlocking tiles, concrete plain tiles, and clay plain tiles. For fibre cement slates, please see pages 159-160.



Shown with plain tiles

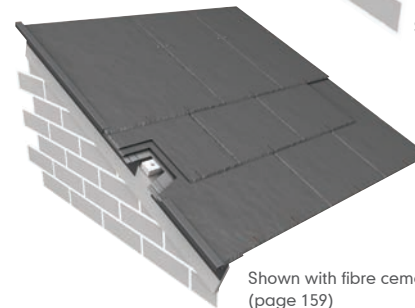

Shown with fibre cement slates
(page 159)

COMPONENTS

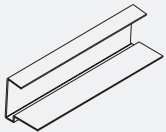

Universal plain
tile, Ashmore and
Edgemere
dry verge (3m)
(code 38501)



Plain tile dry verge
fixing kit
(code 38510)

Kit contains:
1 No. Connector unit,
15 No. 35mm x 2.65mm
ARS stainless steel nails,
2 No. 25mm x 10g
stainless steel screws

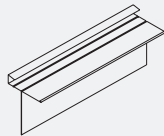

Fibre cement slates
verge trim (3m)
(code MA42206)

CONTINUOUS DRY VERGE

INSTALLATION

- 1 Ensure the gable end is level and free from projections. The roofing underlay and tiling battens should be laid across the cavity/gable ladder and the battens finished flush with the outer wall or outer edge of the bargeboard (Fig. 10). The verge extrusion is fitted prior to tiling.
- 2 Square cut the ends of the verge extrusion to the desired length. A connector unit is available to join lengths of extrusion. At the eaves, cut away a length of horizontal flange to accommodate the tilting fillet or support tray (Fig. 11).

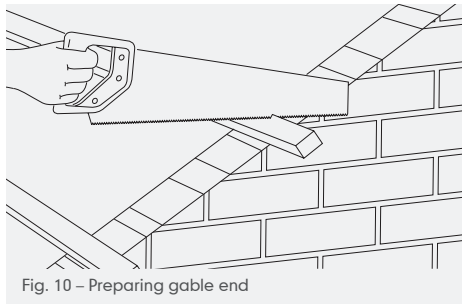

Fig. 10 – Preparing gable end

- The verge should be cut square, flush to the lower tile, and notched into the gutter
- 3 At the ridge apex, allow a 10mm expansion gap at the mitred joint between the verge extrusions. Cut away the top flange and 20mm depth of the side wall (Fig. 12) to accommodate the ridge tile (and dry ridge batten section, if appropriate).
 - 4 The horizontal flange of the extrusion is pushed between the top of the wall (or gable ladder) and tiling battens along its whole length. Ensure the bottom end lines up with the leading edge of the eaves tiling course (Fig. 12).

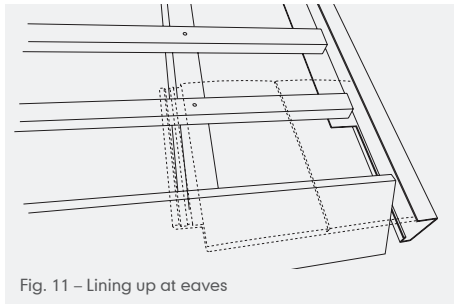

Fig. 11 – Lining up at eaves

- 5 Where necessary, a connector unit is fitted at joints between extrusions (Fig. 13).

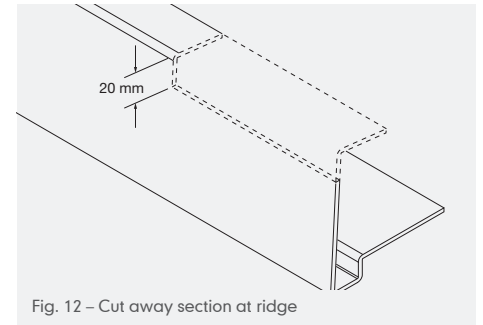

Fig. 12 – Cut away section at ridge

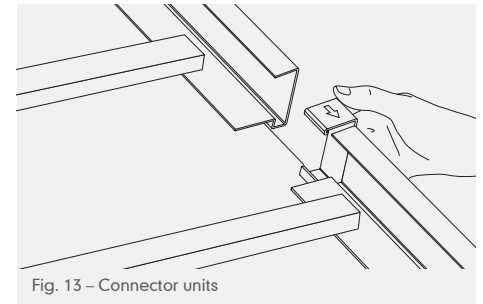

Fig. 13 – Connector units

CONTINUOUS DRY VERGE

- 6 Secure the verge extrusion by driving annular ring shank nails through each tiling batten (40mm from the end) into the extrusion (Fig 14). Alternatively, fix with masonry nails, drill out, then plug and screw to top of gable (if brickwork).
- 7 Lay tiles in the usual manner, ensuring the verge tiles are fully inserted into the verge extrusion and mechanically fixed (Fig. 15).
- 2 When using a ridge end cap with either the Marley dry ridge or RidgeFast systems, the bottom flange of the cap will need to be reduced to 25mm overall depth (Fig. 17).
Fix the ridge end cap using the 2 No. 25mm x 10g stainless steel screws provided in the fixing kit.
- 3 When using a bedded ridge and/or block end ridge tile, the verge extrusion will need to be cut away to accommodate the internal rib of the tile and provide a close fit to the outer face of the verge extrusion (Fig. 18).

FIXING AT RIDGE

- 1 When used with the Marley dry ridge system, low profile batten sections should extend 15mm beyond the outer wall or outer edge of the bargeboard (Fig. 16).

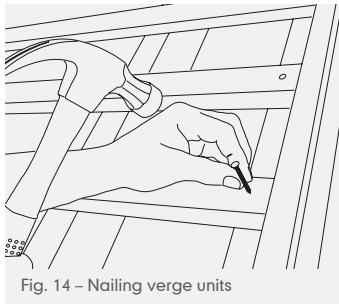

Fig. 14 – Nailing verge units

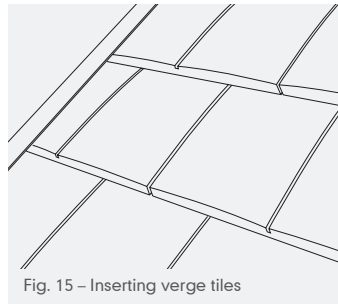

Fig. 15 – Inserting verge tiles

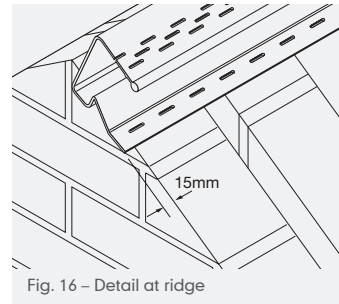

Fig. 16 – Detail at ridge

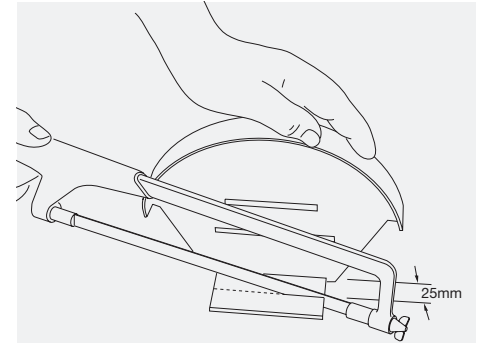

Fig. 17 – Trimming the ridge cap

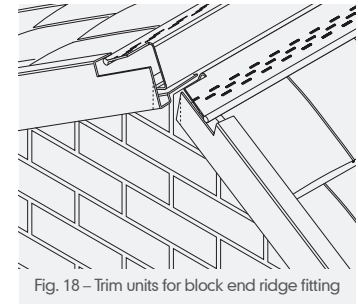

Fig. 18 – Trim units for block end ridge fitting

CONTINUOUS DRY VERGE FOR SLATES

- 1 Underlay and battens should be laid and cut flush with outer edge of gable wall or bargeboard.
- 2 Position the verge trim on top of the battens and align the vertical leg against the batten ends.
- 3 Position the first length to overhang at the eaves into the gutter, by the required amount, and remove part of the down leg to allow fitting of the gutter (Fig. 19).
- 4 Nail the horizontal flange of the trim to each batten using a 25mm long galvanised clout nail ensuring the batten ends are nailed to the substructure.
- 5 When joining adjacent lengths of verge trim, ensure the lower length of trim is nailed securely to each batten (joints at the centre of a batten) (Fig. 20).
- 6 Cut away a rectangle 15mm in from the end of the trim beneath the drip bead (Fig. 21).
- 7 Trim the inside corner of the trim. Make a small triangular cut into the top lap of the trim and press down slightly (Fig. 21). This will allow the upper length to push inside the lower length.



Fig. 19 – Nail each length of trim to batten

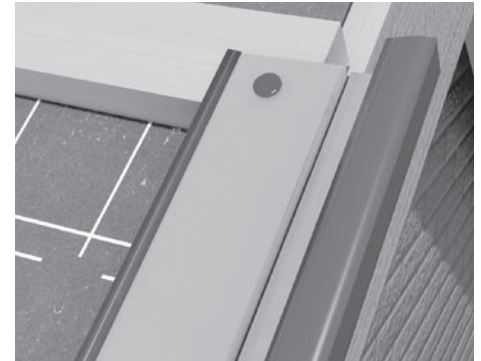

Fig. 20 – Cut 15mm in from end of trim

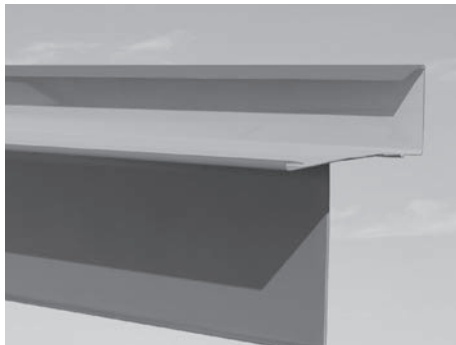

Fig. 21 – Make triangular cut

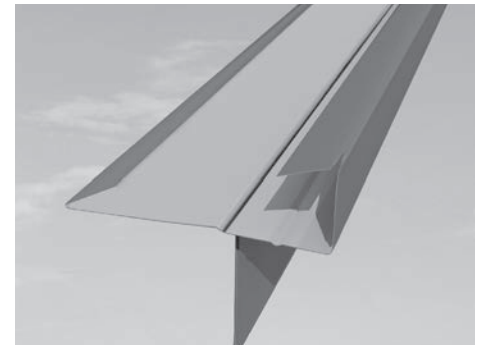

Fig. 22 – Insert upslope trim into lower trim section

CONTINUOUS DRY VERGE FOR SLATES

- 8 Ensure the two down legs line up. Firmly push into place and nail into position (Fig. 23). If the upper leg is to form part of a ridge joint, carry out the apex cutting process prior to nailing to battens.
- 9 Slide the verge slates under the lip of the verge. Trim and nail in accordance with the recommended fixing specification.

Please note that sheet metal cutters should always be used to cut the trim. Use protective gloves when handling to avoid injury from sharp edges.



Fig. 23

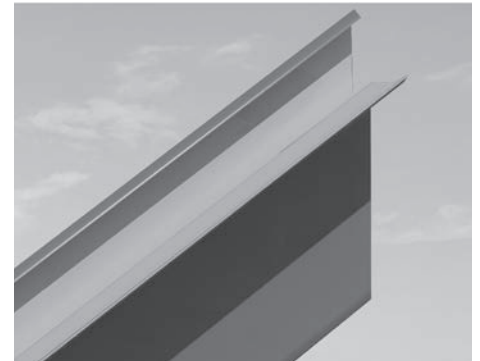

Fig. 24 – Cut trim to correct angle

INSTALLATION AT RIDGE APEX

- 1 Prior to fixing, offer the left hand trim up to the apex of the ridge and plumb cut the depth of the trim to the desired angle dependent on pitch of the roof (Fig. 24).
- 2 Cut away a slot 30mm x 5mm behind the down leg (Fig. 25).
- 3 Nail the left hand trim into place (Fig. 26).
- 4 Carefully interlock the right hand length of trim into the left hand length (Fig. 27). The down leg of the right hand length should slot behind the left hand length. Nail the right hand length into position.



Fig. 25 – Cut slot



Fig. 26 – Nail left hand trim in place



Fig. 27 – Interlock left and right hand trims

INTERLOCKING TILE CLOAK VERGE SYSTEM

Marley cloak verge systems eliminate the need for mortar bedding. They provide a mechanically fixed, durable and maintenance-free finish to the roof verge.



INTERLOCKING TILE CLOAK VERGE SYSTEM

COMPONENTS

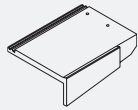

Modern cloak
verge tile

(RH code 370, LH code 371)



Modern half tile
(code 372)



Fixing kit for Modern
(28 No. fixings, code 53730)

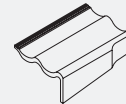

Mendip cloak
verge tile

(RH code 246, LH code 245)



Mendip half tile
(code 247)



Fixing kit for Mendip
and Double Roman
(28 No. fixings, code 54252)

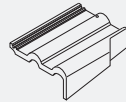

Double Roman
cloak verge tile
(RH code 266, LH code 265)

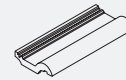

Double Roman
half tile
(code 102)

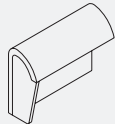

Segmental
mono-ridge block
end ridge

(RH code 190, LH code 189)

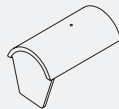

Segmental block
end ridge
(code 191)

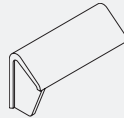

Modern
mono-ridge block
end ridge

(RH code 375, LH code 376)

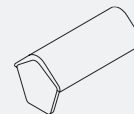

Modern block
end ridge
(code 374)

INSTALLATION

- 1 Install roof underlay and tiling battens in normal manner, allow underlay to overhang verge by approx. 60mm.

Note: Maximum gauge 345mm (75mm lap), minimum gauge 305mm (115mm lap).

- 2 Saw ends of tiling battens off flush with gable wall or bargeboard and coat the cut ends with a suitable timber treatment (Fig. 1). nail within a maximum of 500mm from end.
- 3 For rafter pitches over 30°, where it is not possible to gain a firm fixing for ends of tiling battens, use a double course of battens across a complete rafter span (two fixings minimum), to increase rigidity of system (Fig. 2).

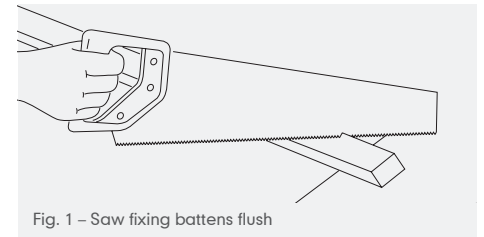

Fig. 1 – Saw fixing battens flush

INTERLOCKING TILE CLOAK VERGE SYSTEM

4 If, during setting out, vertical leg of cloak verge unit cannot be closely fitted (max. 16mm gap) with brickwork or bargeboard, fix fibre cement undercloak strip beneath tiling battens, to prevent ingress of birds and vermin (Fig. 2).

Note: Maximum overhang using this method must not exceed 60mm, measured to outside of verge unit.

5 Position cloak verge unit at eaves and mark position where embedded PVC channel on underside rests on fascia or tilting fillet.

6 Remove cloak verge unit and nail comb filler, or cut filler as applicable to top of fascia (excluding Modern).

7 Drive the stainless steel angular ring shanked nail with nylon spacer unit (supplied in Fixing Kit) into top of fascia or tilting fillet to coincide with position of embedded PVC channel.

8 Ensure nail and spacer assembly is fitted to align with the pitch of roof.

9 Leave a small amount of play to allow cloak verge unit to slide down and engage spacer unit (Fig. 3).

10 Ensure nibs of cloak verge unit are correctly located against top edge of tiling batten.

11 Drive aluminium nail with spacer unit assembly, through cloak verge nail hole, leaving a degree of free play (Fig. 4).

12 Lay next cloak verge unit in a similar manner, by sliding it down so that embedded PVC channel locates over nylon spacer unit and tile nibs are in contact with tiling battens (Fig. 5).

Note: Nail holes in cloak verge half tiles should be sealed with mastic, when used on roof pitches below 25° and should be clip fixed where required.

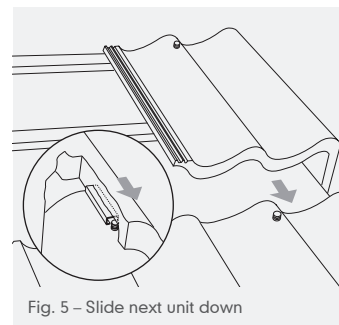
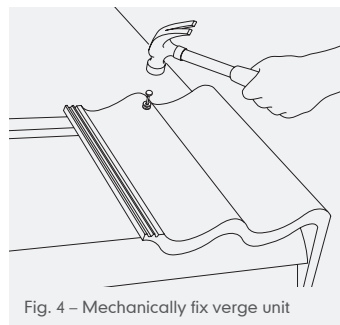
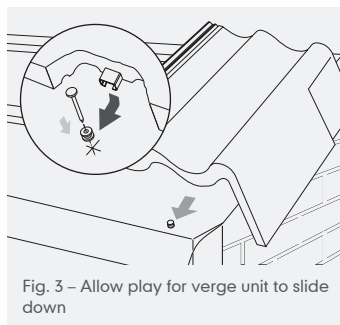
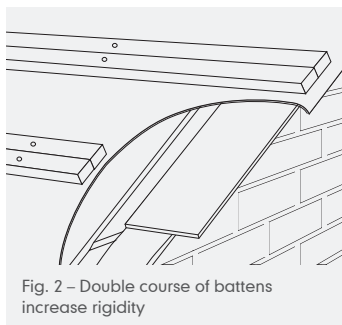

INTERLOCKING TILE CLOAK VERGE SYSTEM

13 Install remaining cloak verge units in the same way and tile roof in normal manner.

14 Fit half tiles, if required, either next to cloak tiles or elsewhere in tiling, ensuring that bond is maintained throughout. Fix by either nail and/or clip fixing.

Lay Modern cloak verge half tiles in alternate courses adjacent to cloak verge units to maintain broken bond of roof tiles (Fig. 6).

15 When installing cloak verge tiles with Marley dry ridge system for both left hand and right hand top course cloak verge tiles, cut away embedded PVC channel at rear for a distance of 20mm.

This allows nylon spacer to cloak verge tile below to locate into the channel.

16 Push cloak verge tile upwards and fit into dry ridge batten section (Fig. 7).

17 Install Segmental or Modern block end ridge by either bedding in mortar, or mechanically fixing using Marley Dry Ridge System or Universal RidgeFast. Mono-ridge block end tiles are available for mono-pitch roofs (Figs. 8 and 9).

Note: Segmental mono-ridge tiles should be used with Marley Dry Mono-ridge system. When using the Marley Dry Ridge System, the block end ridge tile should be fixed using a supplementary ridge union fitted over the top of the ridge tile near to the end of the ridge.

18 When using the Marley Dry Ridge System, the block end ridge tile should be fixed using a supplementary ridge union fitted over the top of the ridge tile near to the end of the ridge.

A maximum 5mm cut (Fig. 8) should be made in the base of the ridge tile to accommodate the 'claw' of the ridge union. The lugs on the underside of the union should be broken off.

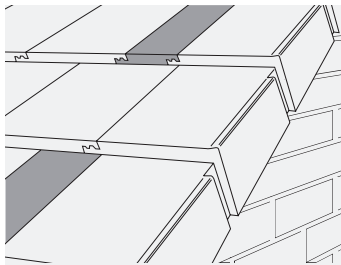

Fig. 6 – Maintain broken bond with half tiles for Modern Cloak Verge

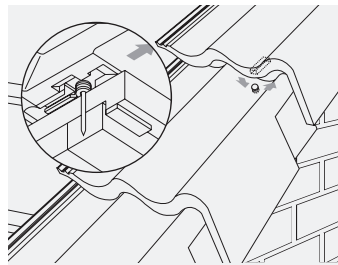

Fig. 7 – Engage nylon spacer with nail into channel of verge unit

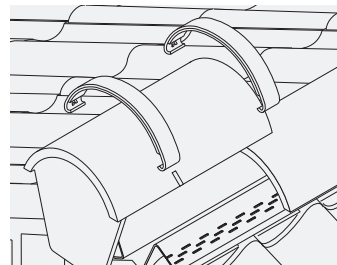

Fig. 8 – Completion at ridge

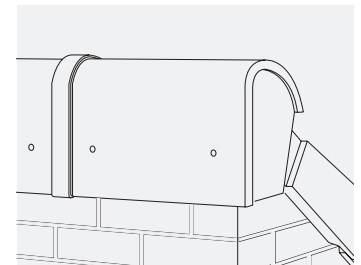
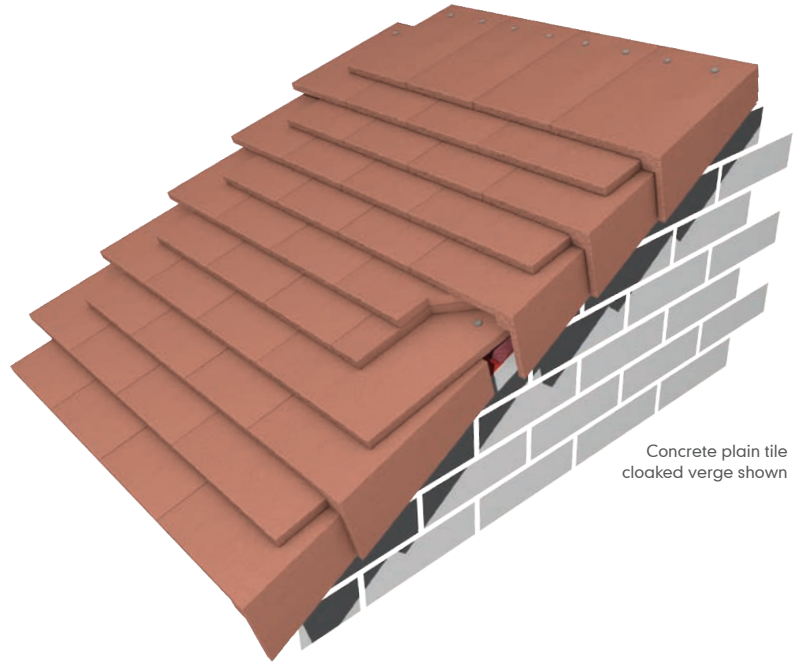

Fig. 9 – Completion at mono-ridge

CLAY AND CONCRETE PLAIN TILE CLOAK VERGE SYSTEM

Plain tile cloak verges provide a weatherproof and mortar free finish to the roof verge. They are available in right and left hand units in colours to match the main roof tiles, twice nailed for maximum security. The apex of the roof is finished with matching stop-end ridge tiles.



Concrete plain tile
cloak verge shown

CLAY PLAIN TILE CLOAK VERGE SYSTEM

COMPONENTS

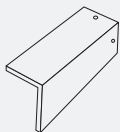

Clay plain tile
right hand
cloak verge

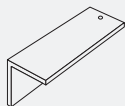

Clay plain tile
left hand
cloak verge

INSTALLATION

- 1 Felt and batten the roof in normal way.
- 2 Set out the tiling so that the leg of the cloak verge fits flush with the brickwork or bargeboard.

If necessary, the tiles adjacent to the cloak verge tiles can be cut to fit, to prevent an overhang at the gable wall or bargeboard to prevent the ingress of birds or vermin. When cutting tiles to fit, ensure the minimum sidelap of 55mm is maintained.

- 3 Commence laying an under-eaves course of tiles using a standard eaves tile (Fig. 3, page 167).

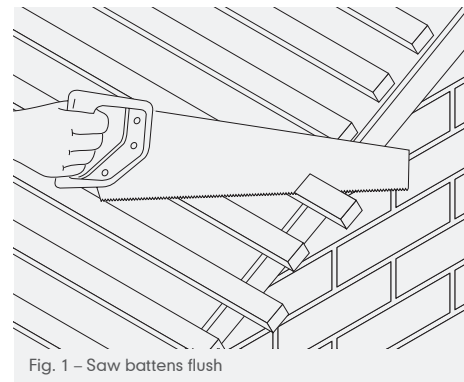

Fig. 1 – Saw battens flush

CLAY PLAIN TILE CLOAK VERGE SYSTEM

- Using a batten end clip, nail the eaves cloak verge tile with 2 No. 38mm x 3.35mm aluminium or stainless steel ring shank nails to both top and end of the tiling batten using the holes in the top and vertical leg (Fig. 3).

Alternatively, if the verge construction allows, a timber batten can be secured to the outer edge of the bargeboard or gable wall to assist screwing the vertical leg of the cloak verge tile.

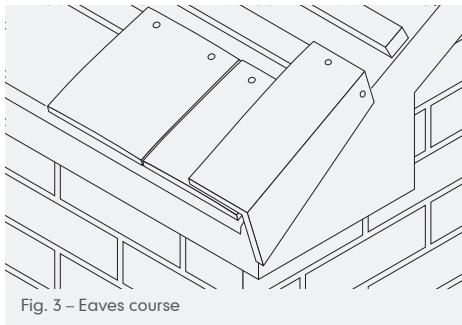

Fig. 3 – Eaves course

- Each alternate course should contain a normal plain tile to break bond, which should be twice nailed using standard 38mm x 2.65mm aluminium or stainless steel nails (Fig. 4).
- The remainder of the verge is completed using successive cloak verge and plain tiles until the apex is reached. The top course may be either a tops/eaves tile or a cloak verge tile cut to size, with nail holes drilled to suit, and fixed as required.

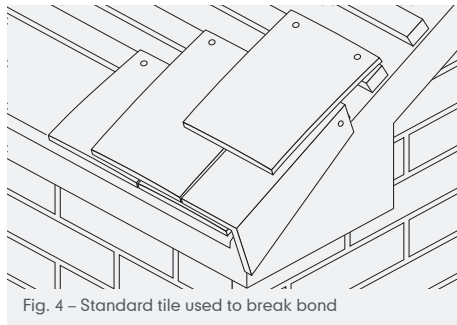

Fig. 4 – Standard tile used to break bond

If necessary, cut the top corners of the vertical legs of the cloaked verge tiles, to avoid clashing under the apex. An additional fixing hole may need to be drilled.

- Complete the apex closure of the two top course cloak verge tiles by fitting a Stop End Ridge tile and a tile-and-a-half/gable tile, cut to fit between the vertical legs of the top course cloak verge tiles. Drill and screw cut tile to timber battens or ridge tree (Fig. 5).
- Either mortar bed end ridge tile with mechanical fixing, or use a dry fix system.

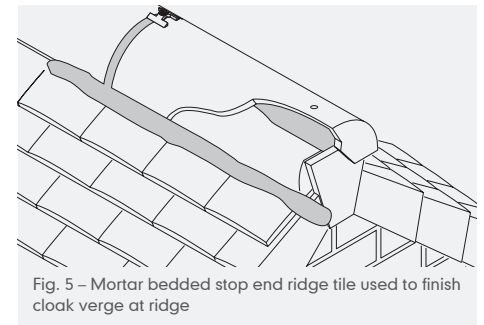
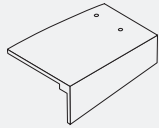

Fig. 5 – Mortar bedded stop end ridge tile used to finish cloak verge at ridge

CONCRETE PLAIN TILE CLOAK VERGE SYSTEM

COMPONENTS



Concrete plain
tile right hand
cloak verge
(code 250)

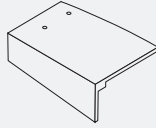

Concrete plain
tile left hand
cloak verge
(code 249)

INSTALLATION

- 1 Felt and batten the roof in normal way.
- 2 Set out tiling so that cloak verge tile fits flush with brickwork or bargeboard (Fig. 6).
- 3 If necessary, the tiles adjacent to the cloak verge tiles can be cut to fit, to prevent an overhang at the gable wall or bargeboard to prevent the ingress of birds or vermin. When cutting tiles to fit, ensure the minimum sidelap of 55mm is maintained.
- 4 Fix under-eaves course using either a normal eaves tile or cloak tile cut down to size (Fig. 7).
- 5 Each alternate course should contain a tile-and-a-half to break bond and must be twice nailed (Fig. 8).

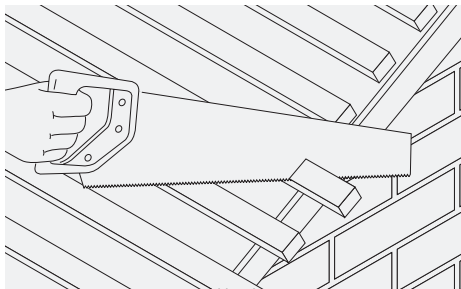

Fig. 6 - Saw battens flush

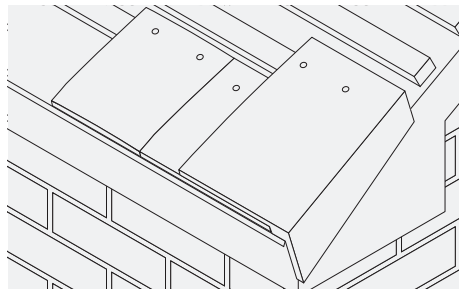

Fig. 7 - Eaves course

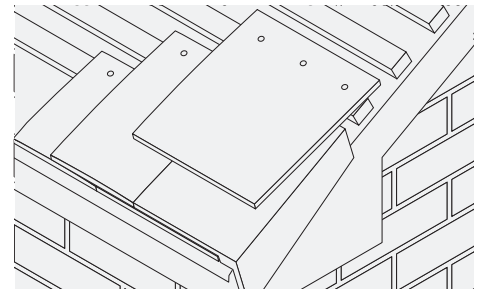

Fig. 8 - Tile-and-a-half used to break bond

CONCRETE PLAIN TILE CLOAK VERGE SYSTEM

- 6 Build up verges with successive cloak verge and tile-and-a-half tiles until apex is reached. The top course may be either an eaves/tops tile or a cloak verge tile cut to size with nail holes drilled and twice fixed as required (Fig. 9).
7. Lay block end segmental ridge either bedded in mortar and mechanically fixed or using a dry fix ridge system, such as RidgeFast ensuring a second mechanical fix through the hole in the end of the block end ridge unit (Fig. 10).

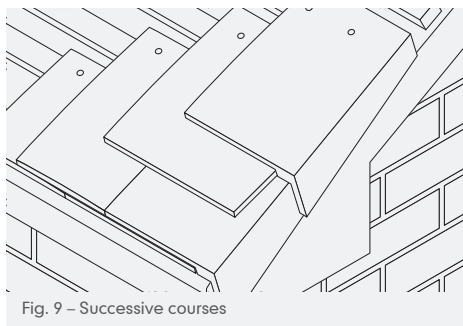

Fig. 9 – Successive courses

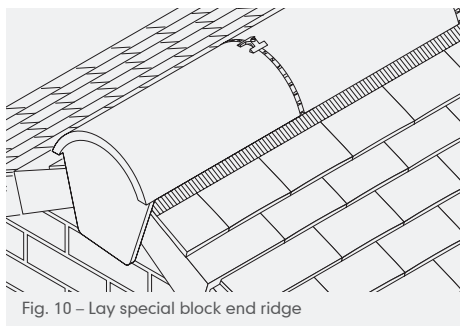
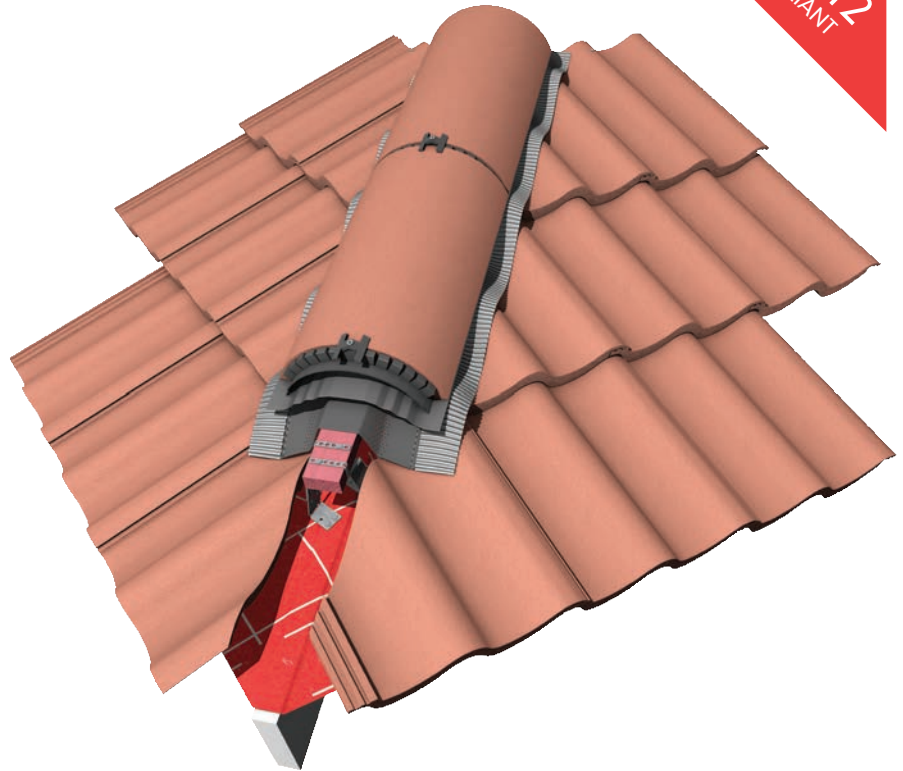

Fig. 10 – Lay special block end ridge

UNIVERSAL HIPFAST SYSTEM

HipFast is a simple and rapidly installed, dry fixed hip system suited to all Marley tiles and slates, as well as those of other manufacturers.



BS 8612
COMPLIANT

UNIVERSAL HIPFAST SYSTEM

COMPONENTS

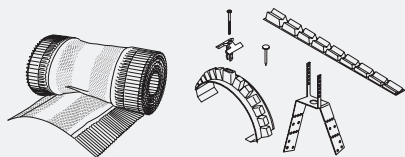

Universal 6m HipFast system
(code 53400)

Kit contains: 1 No. 6m length hip roll,
6 No. batten brackets, 13 No. unions and clamps,
2 No. tapered filler units, 16 No. 75mm x 4.8mm
s/s screws, 36 No. 25mm x 3.35mm s/s ARS nails,
3 No. washers, 24 No. tile head C clips,
36 No. tile tail clips

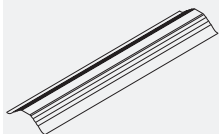

Universal HipFast
support tray*
(code 34002)



RidgeFast/HipFast
union pack*
(code 53303)

* Sold separately

INSTALLATION

1 Lay roof underlay and battens in the normal manner, leaving a 5mm continuous gap in underlay either side of hip rafter if roof void is to be ventilated to recommendations of BS 5250. Mitre cut the ends of tiling battens and support on hip rafter (Fig. 1).

If rigid sarking is used, finish the board at side of hip rafter (allow a 5mm continuous gap either side of the hip rafter if the roof void is to be ventilated).

2 Fix Hip Batten Brackets to hip rafter using nails provided (4 No. per bracket).

Ensure first Bracket is fixed as close as

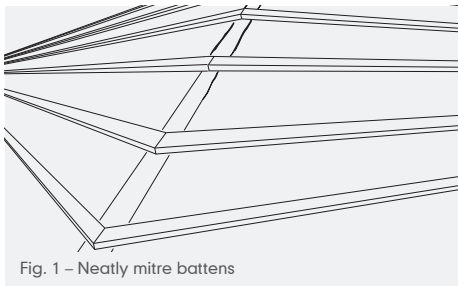

Fig. 1 – Neatly mitre battens

possible to base of the hip rafter and topmost Bracket no more than 100mm from hip/ridge apex (when fixing with Plain tiles, tiling battens will require trimming back from hip rafter, locally, to provide space for fitting hip brackets) (Fig. 2). Support any batten ends with noggins.

Fix remaining batten brackets equally over the length of the hip at max 1m centres.

Batten Brackets can be fitted at a choice of two heights achieved by bending bracket legs inwards along the appropriate diagonal line of holes, (see table on page 175).

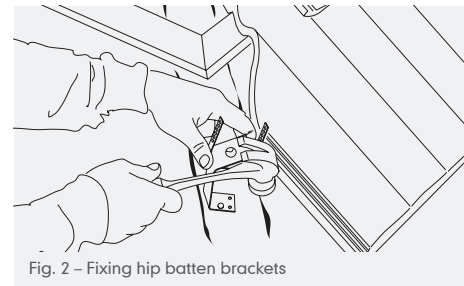

Fig. 2 – Fixing hip batten brackets

UNIVERSAL HIPFAST SYSTEM

- 3 Tile roof leaving a gap of 80mm between raking cut tiles laid adjacent to hip rafter (Fig. 3). Ensure all raking cut tiles and slates are fully supported on the battens and if not, provide suitable packers to prevent tiles from rocking.
- 4 Ensure that all raking cut roof tiles along the length of hip are secured with the C clips and Tail clips provided (sold separately) (Figs. 4 and 5).

In areas of high exposure raking cut tiles or slates may be bonded to adjacent fully fixed tiles or slates using an

appropriate epoxy resin adhesive. This will minimise the risk of smaller cut pieces of tile or slate becoming dislodged. (Details of suitable adhesives can be obtained from the Technical Advisory Service).

Note: When using Plain tiles, ensure that tile-and-a-halves are used on all courses adjacent to the hip, in order to minimise small cut pieces.

- 5 Secure either one or two thicknesses of 50mm x 25mm tiling batten to the top of Batten Brackets, parallel to hip rafter, by folding over Batten Bracket arms and nailing through perforations into the battens using nails provided (Fig. 6).

Where two battens are needed, ensure lowest is screwed to upper batten before locating into Batten Brackets, with any joints in hip battens made over Batten Brackets to ensure both ends are fixed.

Note: To establish if one or two batten thicknesses are required, place a hip tile over the hip junction at the highest point of the tiling and assess the space remaining between the top of the batten bracket and the underside of the hip tile. Install two battens where two battens locate without fouling the hip tile.

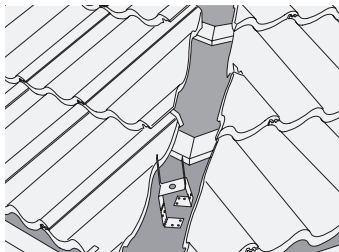

Fig. 3 - Lay tile to hip with raking cut

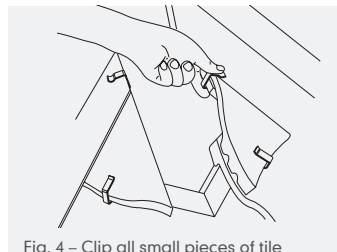

Fig. 4 - Clip all small pieces of tile along hip

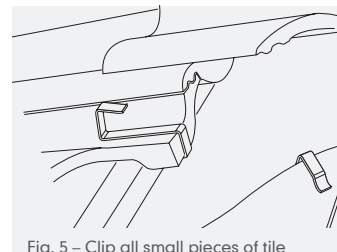

Fig. 5 - Clip all small pieces of tile along hip

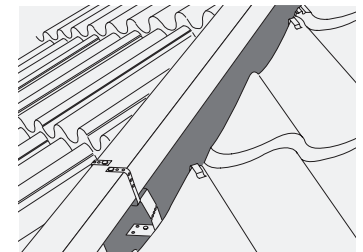

Fig. 6 - Fixing hip batten

UNIVERSAL HIPFAST SYSTEM

- 6 Wash off any surface dust on raking cut tiles with brush and water and allow to dry thoroughly prior to sticking down the HipFast Roll.
- 7 Starting from eaves, roll out HipFast roll centrally over hip rafter battens, and secure in position using well spaced felt nails, leaving a distance of 100mm to oversail the hip/ridge apex. Joints along hip should be lapped by 100mm to drain water down roof (Fig. 7).
- 8 Remove backing tape covering both mastic strips from underside of the roll (Fig. 8). Press adhesive strips on both

sides of hip firmly onto tiles below to ensure a continuous seal along length of both sides of hip.

Both sides should be dressed down together to ensure edge of roll is kept aligned. Avoid stretching HipFast Roll during fitting.

- 9 In all applications it is recommended that HipFast support trays (34002) be used. These are designed to ensure the correct support and alignment of hip tiles. Cut a HipFast Hip Support Tray to suit angle and overhang of tiles at eaves (Fig. 9).

- 10 Fit a purpose designed Block End Hip tile tight against eaves tiles and trim the Block End if required to suit the height of the guttering. Fix Block End Hip tile through HipFast Hip Support Tray to hip batten using 75mm x 4.8mm screw and sealing washer provided. Tighten securely to ensure a firm seal (Fig. 10).

For Lincoln clay interlocking tiles, see pages 113-121.

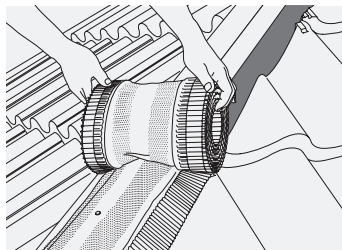

Fig. 7 – Roll out HipFast roll

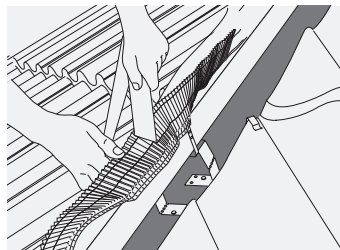

Fig. 8 – Remove backing tape

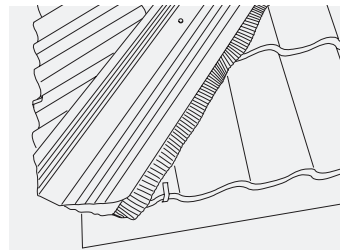

Fig. 9 – HipFast support tray cut at eaves

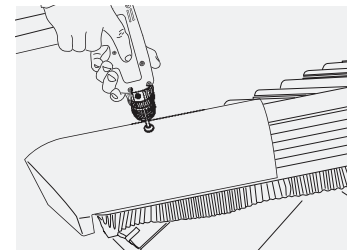

Fig. 10 – Fixing Block End Hip tile

UNIVERSAL HIPFAST SYSTEM

12 Select a hip union, union clamp and 75 x 4.8mm screw. Fit a union clamp into the central slot in the hip union and offer up the assembly into the open end of the hip tile so that it is trapped between the clamp and the union flange. Where the ends on the union overlap the edges of the hip tile, cut off or fold inward the excess length along the crease lines at either end (Fig. 11).

When the union clamp is fully engaged in the hip union, it may create an interference fit with the sub-structure. In this case, the protruding length of the clamp can be snapped off below the hip union flange.

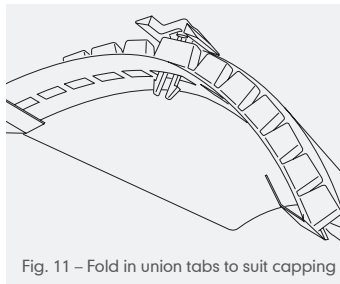

Fig. 11 – Fold in union tabs to suit capping

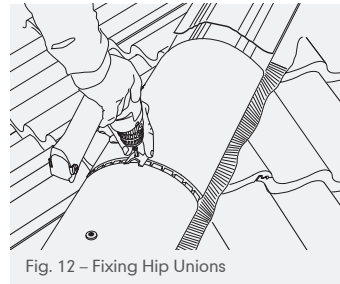

Fig. 12 – Fixing Hip Unions

13 Position next Hip tile into open side of Hip Union and Clamp assembly. Continue process of laying support trays (centrally along hip tree at 100mm overlap), hip tiles, unions and clamps ensuring that all tiles are aligned. Ensure screws are tightened well and the edges of the Hip tiles sit evenly on Hip Support Trays (Fig. 12).

14 At apex, ensure final Hip tile is a full length unit, with any adjustments to suit the length of hip taken up by cutting the adjacent one or two Hip tiles.

Top Hip tile should be mitred into other Hip and Ridge tiles. The hip support tray should also be mitred at internal angle.

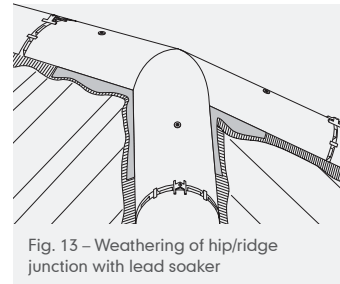

Fig. 13 – Weathering of hip/ridge junction with lead soaker

15 Secure the mitred end of the top Hip tile by drilling a 6mm dia. hole centrally through the tile, approx. 125mm down from the apex, using a masonry drill. Fix the Hip tile to the hip battens using a screw with washer provided and weather all mitre joints using a Code 4 lead saddle or soaker (Fig. 13).

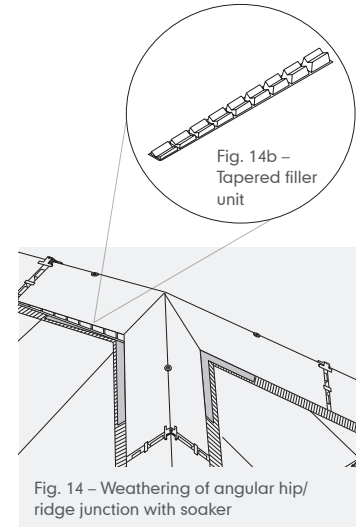

Fig. 14b – Tapered filler unit

Fig. 14 – Weathering of angular hip/ridge junction with soaker

UNIVERSAL HIPFAST SYSTEM

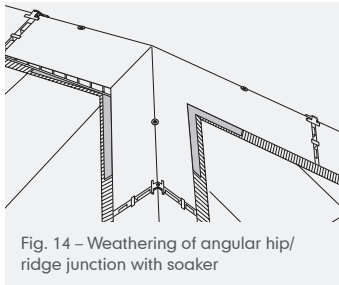

Fig. 14 – Weathering of angular hip/ridge junction with soaker

16 Where Marley RidgeFast is also being used and the hip tiles are the same as the ridge tiles, a Tapered Filler unit must be fitted beneath both edges of the end ridge tile to ensure a close fitting mitre can be achieved at the apex

With profiled tiles, a 500mm length of HipFast Support Tray must be nailed centrally to the ridge batten through the Ridge Roll to act as a bearer for the Tapered Fillers and end ridge tile.

When using flat tiles or slates, the Fillers are trapped between the Ridge Roll and the bottom edges of the ridge tile, with the deeper end toward the hip (Fig. 14).

UNIVERSAL HIPFAST WITH LINCOLN

When using Lincoln clay interlocking tiles with 450mm clay third round hip tiles, a 450mm clay third round stop end hip tile, which is pre-holed for fixing, should be used at the hip ends (Fig. 17). See pages 113-121.

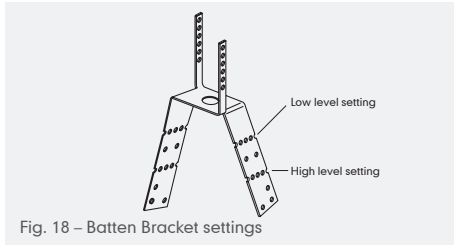

Fig. 18 – Batten Bracket settings

BATTEN BRACKET SETTING TABLE FOR MARLEY ROOF TILES*

Low level batten bracket setting (bend along top row of diagonal holes)

Edgemere (above 25° pitch)

Duo Edgemere (above 25° pitch)

Ashmore

Plain

Ludlow Plus

Ludlow Major (above 32.5° pitch)

High level batten bracket setting (bend along bottom row of diagonal holes)

Edgemere (17.5° to 25° pitch)

Duo Edgemere (17.5° to 25° pitch)

Modern

Duo Modern

Ludlow Major (22.5° to 32.5° pitch)

Double Roman

Mendip

Wessex

Anglia

Lincoln

Eden

* Apply same settings for other manufacturers equivalent tile profiles.

DRY HIP SYSTEM

The Marley dry hip system has been developed to provide a mechanically fixed, weathertight and maintenance-free system for hipped roofs without the need for mortar bedding. It is suitable for use with all Marley concrete plain tiles and concrete interlocking tiles and is designed for use with third round and modern hip tiles.

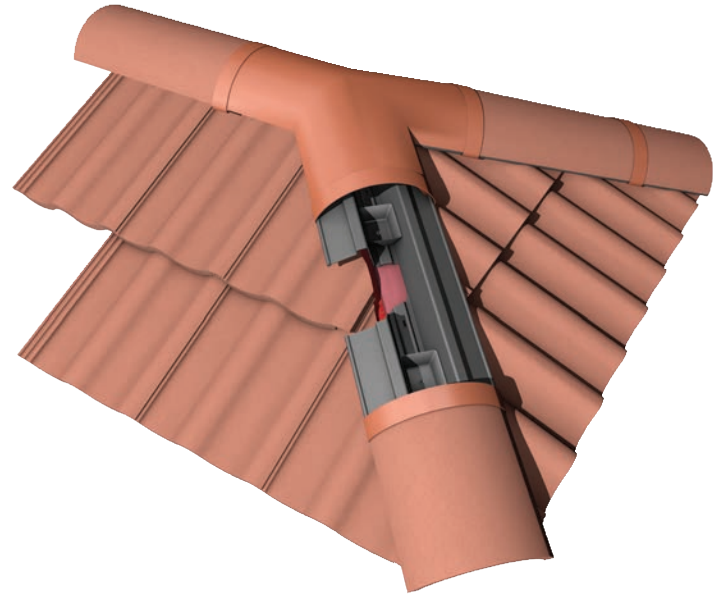

DRY HIP SYSTEM

COMPONENTS

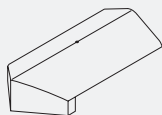

Modern block
end hip tile
(code 292)

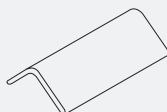

Modern ridge/
hip tile
(code 209)

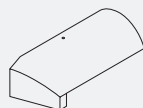

Third round block
end hip tile
(code 291)



Third round
hip tile
(code 289)



Tile tail clip pack
(20 clips)
(code 43602)



Head clips
(code 43607)



Modern ridge/hip
union
(code 4140*)



Third round
hip union
(code 4350*)

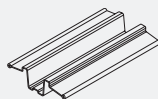

Dry hip batten
section
(code 43300)



Modern hip apex
cap units

15°-24° (code 4381*)
25°-35° (code 4382*)
36°-45° (code 4383*)

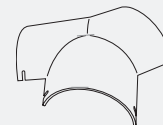

Third round hip
apex cap units

15°-24° (code 4371*)
25°-35° (code 4372*)
36°-45° (code 4373*)

Dry hip system fixing kit

(code 54360)

Kit contains: 2 No. 3m
lengths of closed-cell
rubber foam strips,
5 No. PVCu fixing/
expansion blocks,
12 No. head clips,
2 No. PVCu 'H' section clips,
18 No. tail clips,
7 No. 75mm x 10g s/s
drive screws,
1 No. block end hip
bracket and set screw
with sealing washer

* Use colour code suffix: 1 - Grey, 3 - Brown, 4 - Terracotta.

DRY HIP SYSTEM

INSTALLATION

If using high profile tiles with overall depth less than 85mm, the batten section needs to be screwed through the battens or an additional piece of packing timber needs to be used, sized 15-25mm to suit (or standard 50x25mm batten will suffice), see Fig. 1b.

- 1 Install underlay and battens in the normal manner, ensuring ends of the tiling battens are cut neatly to a mitre and nailed to hip tree or rafter.

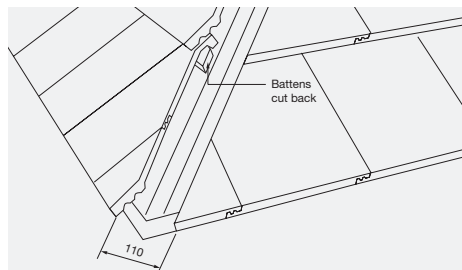

Fig. 1a – If using low profile tiles (depth less than 85mm) form a gap of 110mm at hip

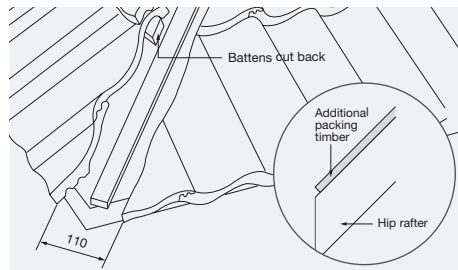

Fig. 1b – If using high profile tiles (depth more than 85mm)

Note: In situations where counter battens and/or rigid sarking have been fixed to adjacent roof slopes, an additional timber batten of equivalent depth, must be securely fixed to top of hip rafter.

- 2 Lay roof tiles in normal manner and fix in accordance with specification.
- 3 If using low profile tiles with depth from rafters to top of tile of less than 85mm, the battens need to be cut back to the width of 110mm and the hip batten section screwed directly to the roof structure (Fig. 1a).

- 4 Secure any small cut pieces of tile to adjacent large tile by means of the special head clip (supplied in the fixing kit) and ensure they are fully supported at hip intersection. Ensure orientation of clip is such that end of throat is flush with cut tile (Figs. 2 and 3).

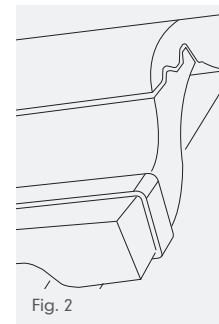

Fig. 2

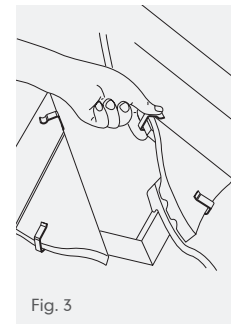

Fig. 3

DRY HIP SYSTEM

- 5 In addition, prevent any small cut pieces of tile from slipping down the roof slope by using tail clip (supplied in fixing kit), which is simply bent over back of tile below and fitted over front edge of the cut tile (Fig. 3 , page 178).

In areas of high exposure raking cut tiles or slates may be bonded to adjacent fully fixed tiles or slates using an appropriate epoxy resin adhesive. This will minimise the risk of smaller cut pieces of tile or slate becoming dislodged.

Note: When using Plain tiles, ensure that tile-and-a-half-tiles are used on all courses adjacent to the hip, in order to minimise small cut pieces adjacent to the hip.

- 6 Insert the closed cell foam rubber strip (supplied in fixing kit), into recesses on each side of PVCu extruded dry hip batten section (Fig. 4).
- 7 Trim top flanges of batten section to maintain angle of external corner of hip. If necessary, make a horizontal cut in walls of batten section, to enable it to fit over fascia upstand (Fig. 5).
- 8 Locate batten section assembly into gap between cut tiles up length of hip. Two or more lengths may be joined together up hip, ensuring that closed cell foam rubber strip from each section abuts tightly to prevent water ingress (Fig. 6).

- 9 Fit small 'H' section PVCu clips (included in fixing kit), onto top flange of batten section each side of butt joint to provide added support.
- 10 Locate PVCu fixing/expansion blocks inside the dry hip batten section and fix to hip tree or rafter using the 75mm x 10g stainless steel drive screws (supplied in fixing kit) (Fig. 7).
- 11 Position first expansion block at eaves, a maximum 185mm from mitred end of batten section. Note the orientation of the fixing/expansion block (as shown in Fig. 8).
- 12 Position remaining fixing/expansion blocks at approximately 565mm centres from first block.

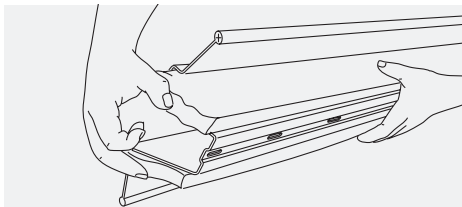

Fig. 4 – Fit foam rubber strip to each side of batten section

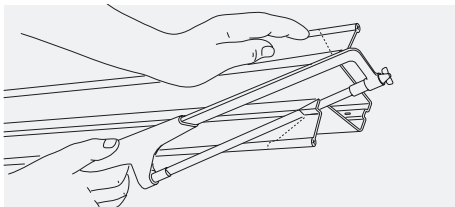

Fig. 5 – Make angled cut, if required

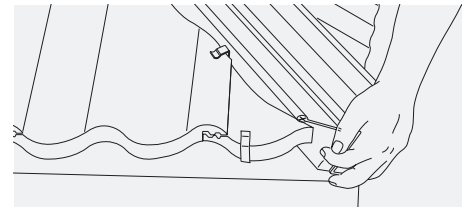

Fig. 6 – Locate hip batten section between cut tiles

DRY HIP SYSTEM

- 13 Screw firmly into position, so that as they reach base of dry hip batten section, they expand sides of section and form a weathertight seal between closed cell foam rubber strip and raking cut roof tiles.
- 14 Fit last block over junction of two lengths of dry hip batten section to firmly secure both ends.
- 15 Fix uppermost fixing/expansion block as close to apex as possible.
- 16 Commence laying hip tiles from eaves using block end hip tile. Ensure that downstand at end does not foul eaves gutter, and trim if necessary, using a disc cutter.
- 17 Secure block end hip bracket to underside of block end hip tile by assembling set screw and sealing washer through hole in tile to captive nut on bracket (supplied in the fixing kit) Fig. 9a
- 18 Locate block end hip tile and bracket assembly on to top of circular beads of dry hip batten section, and fix end of bracket to hip rafter using two 75mm x 10g stainless steel drive screws (Fig. 9).
- 19 Firmly secure block end hip tile with a PVCu hip/ridge union fitted over end of tile and clip to the circular beads of dry hip batten section.
- 20 Break off locating lugs on underside of hip/ridge union with pincers or other suitable tool before fitting. Make two small cuts (max. 5mm deep) at either side of block end hip tile to allow claws of hip ridge union to clip onto bead of batten section (Fig. 10, page 181).
- 21 Lay remaining hip tiles up length of hip, with each leg seated on top of circular bead. Leave gap of approximately 3mm between each hip tile to allow clearance for locating lugs of the PVCu hip/ridge unions.

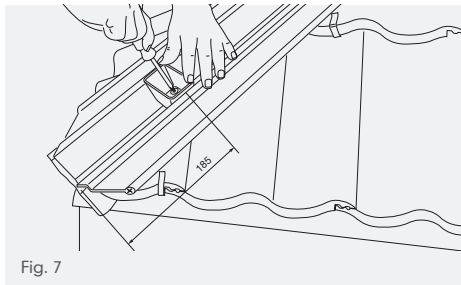

Fig. 7

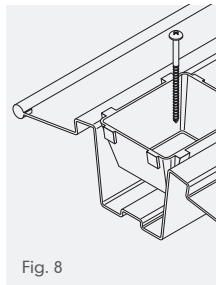

Fig. 8

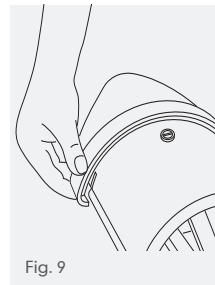

Fig. 9

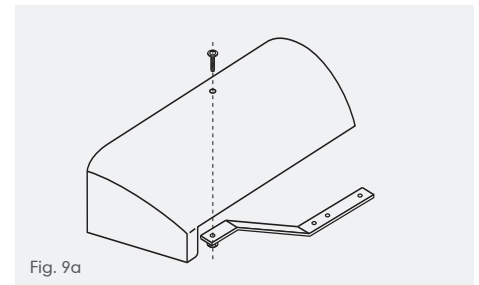

Fig. 9a

DRY HIP SYSTEM

- 22 Secure each hip tile by clipping ends of PVCu hip/ridge union over circular beads of dry hip batten section. Fix any small cut tiles to the larger adjacent tiles with clips provided and/or suitable adhesive (Fig. 13).
- 23 At hip apex, mitre dry hip batten sections together as closely as possible. When forming a junction with the Marley ventilated dry ridge system, cut the foam rubber strip no less than 100mm longer than required and insert into dry ridge batten to ensure a watertight seal' (Fig. 11).
- 24 Place purpose-made apex cap suitable for roof pitch, over uppermost ridge/hip tiles, and mark position of two cut out slots at lower edges. Remove cap and cut a small corresponding slot in hip/ridge tile, maximum 5mm deep (Fig. 12).
- 25 Obtain the three hip/ridge unions suitable for the hip/ridge profile, and break off three central spacers on underside with pincers or other suitable tools. Do not break off the two location lugs remaining.
- 26 Secure legs of apex junction cap with hip/ridge unions ensuring that location lugs align with slot at sides of cap, and are fully clipped to circular beads of dry hip and dry ridge batten sections (Fig. 13). The foam gasket on underside of hip/ridge union must be retained.
- 27 Where universal dry hip system does not terminate at a conventional three-way intersection (or as an alternative to a PVC apex cap), the hip/ridge junction can be weathered with a Code 4 or 5 lead saddle with edges secured in above manner.

Note: Where special roof groundwork is encountered e.g. rigid insulation boards laid above the roof structure, please consult Technical Advisory Service for advice concerning the suitability of fixings.

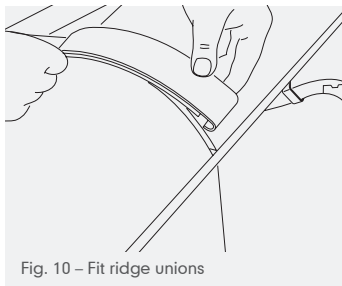

Fig. 10 – Fit ridge unions

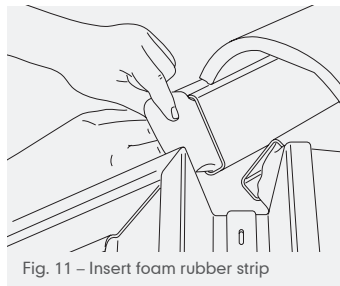

Fig. 11 – Insert foam rubber strip

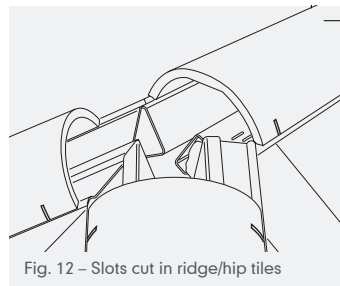

Fig. 12 – Slots cut in ridge/hip tiles

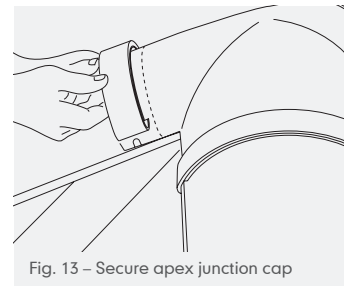

Fig. 13 – Secure apex junction cap

UNIVERSAL DRY VALLEY SYSTEM

Developed to allow the designer freedom to specify a completely mortar-free roof, this system utilises the latest GRP technology.

The advanced and unique gutter section improves discharge rates and gives the appearance of a close-cut finish. Min. pitch 15°.

COMPONENTS

Low profile GRP valley (30422)

3m

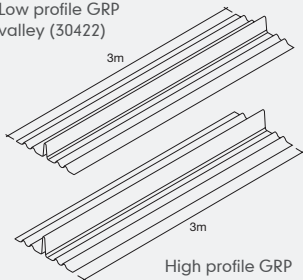

High profile GRP valley (30421)

GRP DRY VALLEY TROUGH SUITABILITY

Tile	High profile	Low profile
Anglia	•	
Ashmore/Plain		•
Double Roman	•	
Eden	•	
Edgemere range		•
Lincoln	•	
Ludlow Major	•	
Ludlow Plus	•	
Mendip	•	
Modern/Duo Modern		•
Wessex	•	

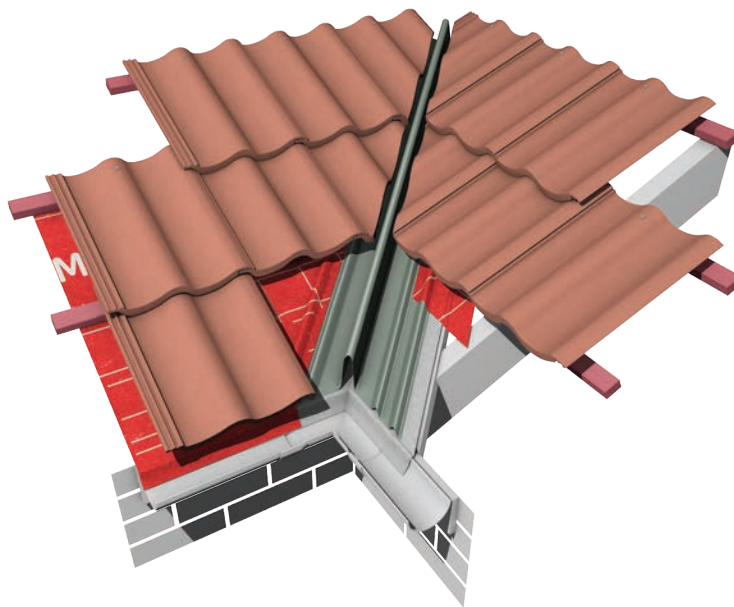

UNIVERSAL DRY VALLEY SYSTEM

- 1 In all cases, valley boards should be fitted. Valley boards may be inset or continuous over the rafters. Where they are inset, they should be a minimum of 12mm thick and supported on bearers or noggins of 50 x 25mm or similar and set at a depth to suit the thickness of the valley board (Fig. 1).
- 2 Continuous overlaid boards should be minimum of 6mm thick plywood and only butt jointed over a supporting rafter (Fig. 2).
- 3 The width of the valley boards should extend by a minimum of 50mm beyond the edge of the valley trough. For overlaid boards on rafter spacings above 450mm, it is recommended that support noggins of 75 x 50mm are fixed under the outer edge of the valley board between the rafters (Fig. 3).

The fascia or barge board may be trimmed to allow the valley trough to pass through without flattening the profile, or alternatively a lead saddle may be used if required.

LINING THE VALLEY

- 4 A single strip of underlay no less than 600mm should be laid down the valley and directly onto the top of the boards allowing for an overlap beyond the fascia line where appropriate and which may be trimmed later (Fig. 3).

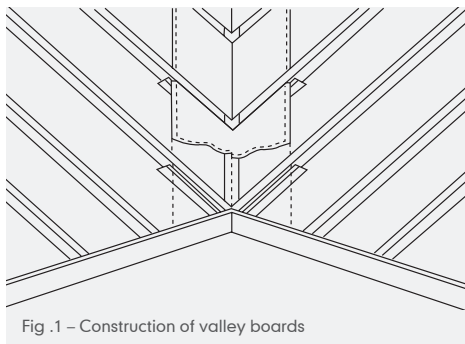

Fig. 1 – Construction of valley boards

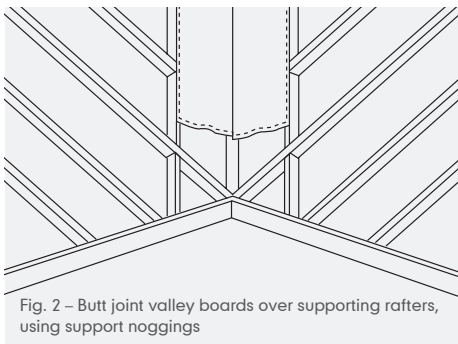

Fig. 2 – Butt joint valley boards over supporting rafters, using support noggins

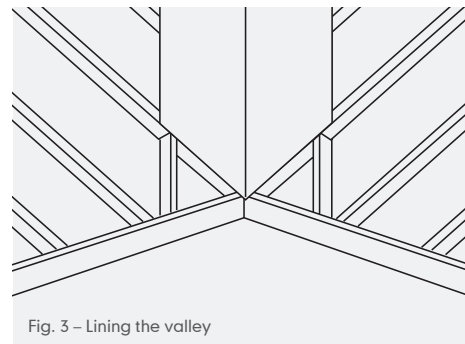

Fig. 3 – Lining the valley

UNIVERSAL DRY VALLEY SYSTEM

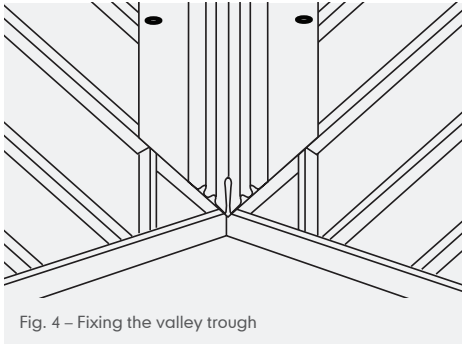

Fig. 4 – Fixing the valley trough

FIXING THE VALLEY TROUGH

- 5 Fix dry valley trough by nailing outer welts to supporting timbers at 500mm max. centres, and overlapping lead (Code 4) apron by a minimum of 150-200mm (Fig. 4).

Lay roof underlay to overlap valley trough and trim between outer and inner welts. Trim tiling. Battens to lap on to outer welt and nail to supporting timbers.

- 6 Where a lead saddle is to be used at the foot of the valley, i.e. where the dry valley terminates above eaves level or where an eaves intersects with a verge or it is not appropriate to notch the fascia boards,

The saddle should be welted at the edge and supported with suitable timber work. The valley trough should be trimmed to suit before fixing if necessary.

LAYING RAKING CUT TILES TO VALLEY TROUGH

- 7 Cut raking tiles neatly to butt closely to central upstand of valley trough and secure all small raking cut tiles with secret cut tile clips and/or a suitable adhesive, or, where applicable, use tile-and-a-half tiles to avoid small cut pieces.
- 8 Fill any small voids in the upstand of the valley trough with a suitable mastic.

UNIVERSAL DRY VALLEY SYSTEM

VALLEY INTERSECTIONS

9 Where a section of dry valley intersects with another section of dry valley e.g. at the roof apex of a dormer roof or where one or more sections intersect with the ridge of a roof, it is necessary to mark the angle of intersection and cut the valley trough prior to fixing, see Figs. 7, 8, 9.

A minimum Code 4 lead saddle should then be dressed over the mitred sections of the dry valley(s) and ridge if necessary. The length of the overlap of the saddle onto the dry valley should be in accordance with LSTA guidance. Alternatively, the lead saddle may be dressed over the slates or tiles.

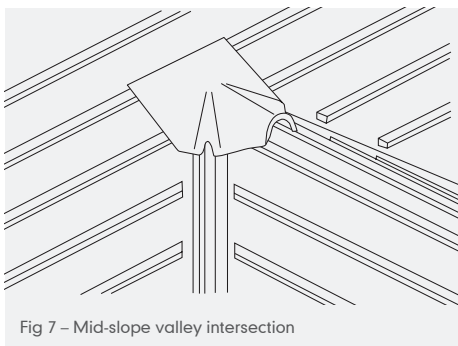

Fig 7 – Mid-slope valley intersection

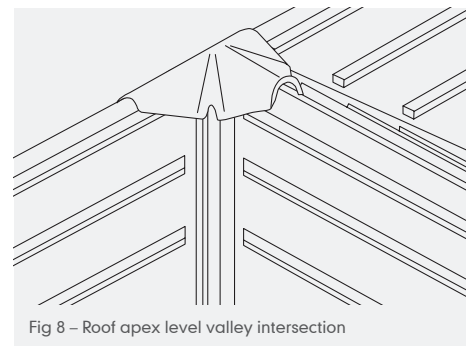

Fig 8 – Roof apex level valley intersection

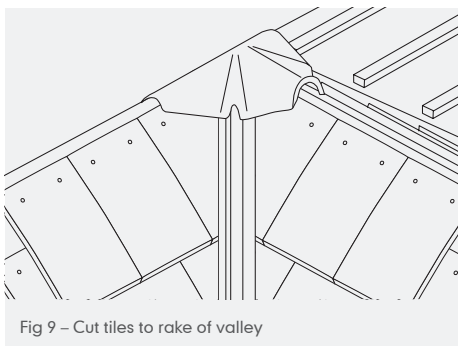
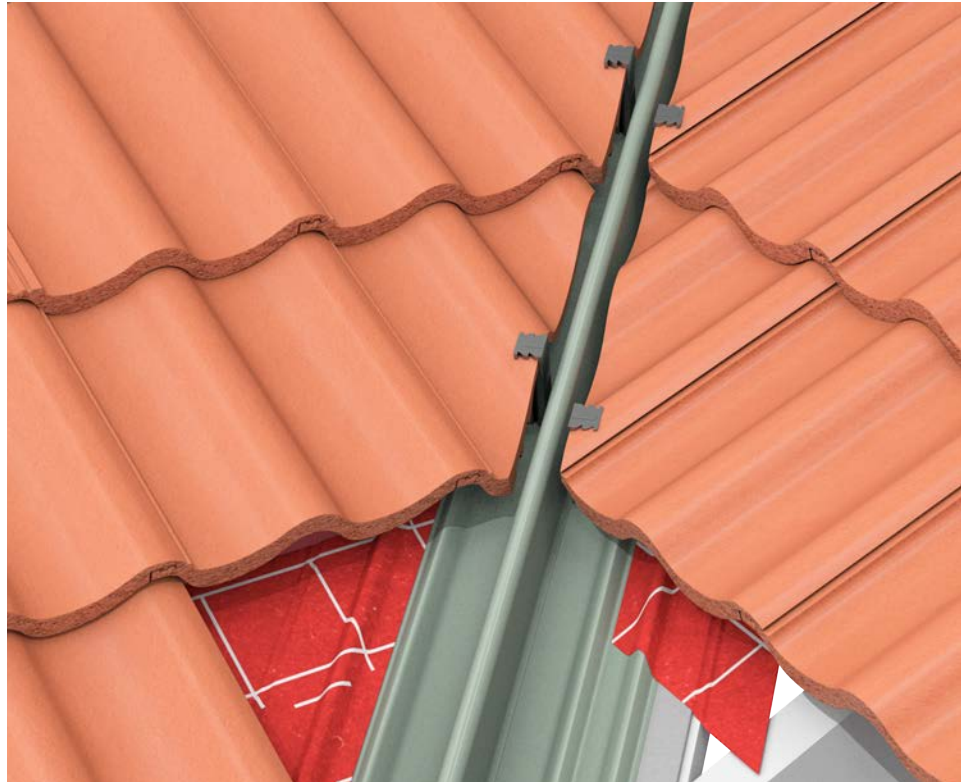
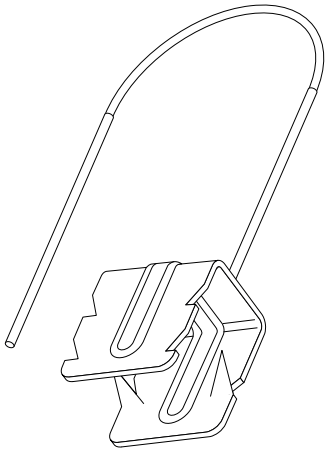

Fig 9 – Cut tiles to rake of valley

Rafter pitch	Max. valley length	Min. lap length
15 to 17°	10.0m	400mm
17.5 to 22°	12.0m	350mm
22.5 to 29°	14.5m	300mm
30 to 34°	15.0m	250mm
35 to 39°	15.5m	200mm
40 to 44°	16.5m	150mm
45 to 49°	17.5m	150mm
50 to 55°	18.5m	150mm

BONDING TILES AND SECRET CUT TILE CLIPS

Secret tile clips can be used to fix small cut tiles to valleys (or hips). The clip should be firmly attached to the cut edge of the tile and fixed to a nearby batten or rafter using a nail/screw and the fixing wire provided.



GRP DRY VALLEY FOR SLATES

Developed to allow the designer freedom to specify a completely mortar-free roof, this system utilises the latest GRP technology. The advanced and unique parabolic gutter section improves discharge rates without added gutter depth.

For use with natural and fibre cement slates (pitch range 22.5° to 45°).

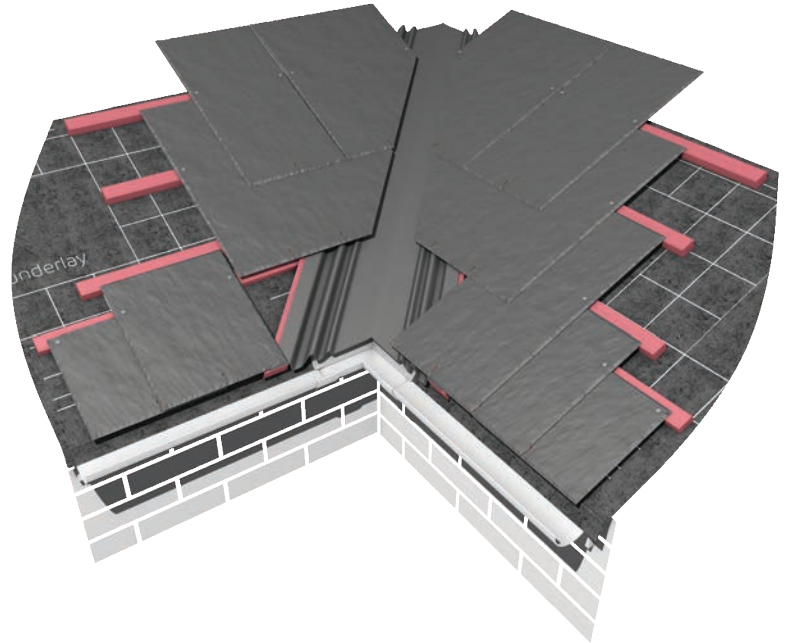

COMPONENTS



GRP slate dry valley trough
(code 30578)

GRP DRY VALLEY FOR SLATES

- 1 The valley trough may be fixed directly onto raking counter battens, or to the valley boards if installed on top of the rafters.
- 2 The valley should first be lined with an approved underlay no less than 600mm wide.
- 3 Raking counter battens of the same depth as the tiling battens should be nailed on top of the valley boards, if inset, and over the underlay.
- 4 The lengths of the valley trough should be firmly pressed down on to the valley board to support the base and nailed, through pre-drilled holes at a maximum of 500mm centres, to the raking counter battens.
- 5 The underlay should then be laid and dressed over the raking counter battens or valley boards and lapped onto the valley trough.
- 6 The fascia board should be cut to allow the GRP valley trough to pass through and discharge into the gutter without

flattening out. The end should be trimmed to the approximate centre line of the gutter.

A lead saddle may be required at the eaves if the fascia board cannot be notched out, or if the fascia board is set too high.

- 7 At the head of the valley, a lead saddle should be fixed to lap over the valley trough.

When joining lengths of dry valley, use the minimum lengths of overlap, as follows:

Roof pitch°	>39	30-39	22.5-29
Overlap (mm)	150	200	300

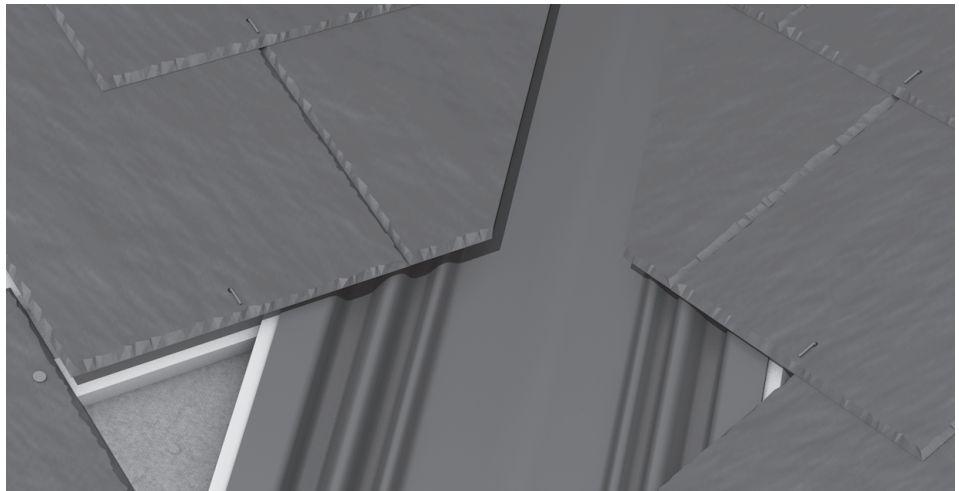

Fig. 1 – Raking cut slates laid with GRP valley trough

UNIVERSAL RIDGEFAST SYSTEM

RidgeFast is a simple and rapidly installed, dry fixed ridge ventilation system suitable for all duo-pitch roofs using all Marley tile and slate profiles, as well as those of other manufacturers.

Universal RidgeFast used with concrete ridge fitting is compatible with natural and fibre cement slates.

If natural or fibre cement ridge fittings are to be used with natural or fibre cement slates, please use Universal Ridge Roll, shown on pages 197-198.

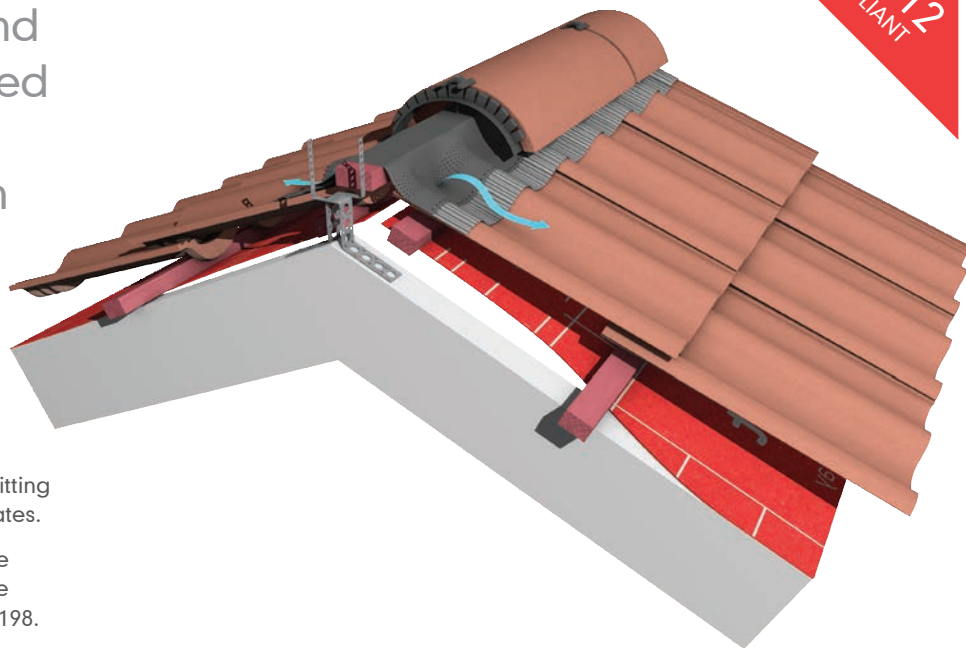

BS 8612
COMPLIANT

UNIVERSAL RIDGEFAST SYSTEM

COMPONENTS

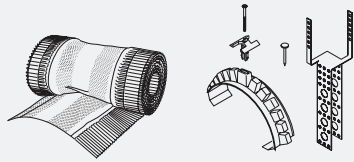

Universal 6m RidgeFast system
(code 33000)

Kit contains: 1 No. 6m length hip roll,
10 No. batten brackets, 13 No. ridge unions,
13 No. ridge union clamps, 13 No. 75mm x 4.8mm
s/s screws, 40 No. 25mm x 2.65mm s/s ARS nails

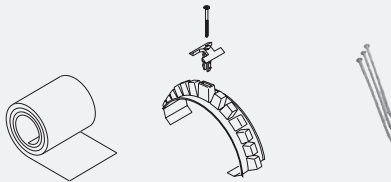

RidgeFast
blanking
tape
(optional)
(code 33001)

Extra ridge
union pack
(optional)
6 per pack
(code 53303)

Deep ridge
screws
(For Eden
and Lincoln,
code 70000)

INSTALLATION

- 1 Lay the roof underlay and battens in the normal manner leaving a minimum 5mm continuous gap in underlay at roof apex (refer to BS 5250 recommendations for specific advice) (Fig. 1).

Before fixing top course tiling batten, fix ridge batten brackets to each rafter, centrally about ridge apex, using the 25mm x 2.65mm dia./s ring shank nails supplied.

Note: Where a ridge tree is in place, a ridge batten bracket may not be required. In this case the ridge tree may be raised in height by fixing appropriately sized lengths of timber centrally to ridge tree.

For ridge trees less than 38mm wide, it may be necessary to drill pilot holes and fix any additional battens with screws rather than nails to avoid splitting the timber.

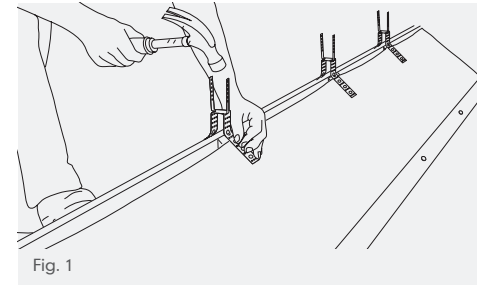

Fig. 1

To achieve the required height of the ridge batten bracket, the legs of the brackets need to be bent at a position which allows the ridge screws to penetrate the ridge batten by no less than 20mm (see table overleaf).

UNIVERSAL RIDGEFAST SYSTEM

BATTEN HEIGHT SETTING*

The first figure gives ridge batten height (in mm), figure in brackets gives hole positions at which ridge batten bracket legs are bent to fix to rafter

Tile	Ridge type	Roof pitch											
		12.5°	15°	17.5°	22.5°	25°	30°	35°	40°	45°	50°	55°	60°
Anglia	Segmental Ridge			50 (4)	50 (3)	50 (3)	50 (3)	50 (3)	50 (2)	50 (2)	50 (1)	50 (1)	50 (1)
Ashmore	Segmental Ridge				50 (1)	50 (1)	50 (1)	50 (1)	25 (1)	25 (1)			
	Modern Ridge				50 (1)	50 (1)	50 (1)	50 (1)	25 (1)	25 (1)			
Concrete Plain	Segmental Ridge							50 (2)	50 (1)	50 (1)	25 (1)	25 (1)	25 (1)
	Modern Ridge							50 (1)	50 (1)	25 (2)	25 (1)	25 (1)	
Double Roman	Segmental Ridge			50 (3)	50 (2)	50 (2)	50 (2)	50 (1)	50 (1)	25 (2)	25 (1)	25 (1)	
Eden	Segmental Ridge				50 (3)	50 (3)	50 (3)	50 (3)	50 (2)	50 (2)	50 (1)	50 (1)	50 (1)
Edgemere range	Segmental Ridge			50 (2)	50 (1)	50 (1)	50 (1)	50 (1)	25 (1)	25 (1)	25 (1)		
	Modern Ridge			50 (2)	50 (1)	50 (1)	50 (1)	50 (1)	25 (1)	25 (1)			
Fibre cement slates	Segmental Ridge		50 (1)	50 (1)	50 (1)	50 (1)	50 (1)	25 (1)	25 (1)	25 (1)			
	Modern Ridge		50 (1)	50 (1)	50 (1)	50 (1)	25 (1)	25 (1)					
Lincoln	Segmental Ridge			50 (4)	50 (3)	50 (3)	50 (3)	50 (3)	50 (2)	50 (1)	50 (1)	50 (1)	50 (1)
Ludlow Major	Segmental Ridge			50 (2)	50 (2)	50 (2)	50 (2)	50 (1)	50 (1)	25 (1)	25 (1)	25 (1)	
	Modern Ridge			50 (2)	50 (2)	50 (2)	50 (1)	50 (1)	50 (1)	25 (1)	25 (1)	25 (1)	
Ludlow Plus	Segmental Ridge				50 (2)	50 (2)	50 (1)	50 (1)	50 (1)	25 (1)	25 (1)		
	Modern Ridge				50 (2)	50 (2)	50 (1)	50 (1)	25 (1)	25 (1)			
Mendip/Wessex	Segmental Ridge		50 (3)	50 (3)	50 (3)	50 (3)	50 (2)	50 (2)	50 (1)	50 (1)	50 (1)	25 (1)	25 (1)
	Modern Ridge		50 (3)	50 (3)	50 (3)	50 (2)	50 (2)	50 (2)	50 (1)	50 (1)	50 (1)		
Modern/Duo Modern	Segmental Ridge			50 (2)	50 (2)	50 (2)	50 (1)	50 (1)	25 (1)	25 (1)	25 (1)		
	Modern Ridge			50 (2)	50 (1)	50 (1)	50 (1)	25 (2)	25 (1)	25 (1)			
Natural slates	Segmental Ridge		50 (1)	50 (1)	50 (1)	50 (1)	50 (1)	25 (1)	25 (1)	25 (1)			
	Modern Ridge		50 (1)	50 (1)	50 (1)	50 (1)	25 (1)	25 (1)					

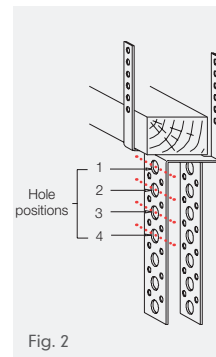

Fig. 2
Note: Bracket legs should be bent across the centres of the larger holes, as indicated by the dotted red lines.

- 2 Fix the top course tiling battens into position, over the ridge batten brackets, leaving sufficient room for the tile nibs and to ensure the ridge tiles overlap the top course of tiles by no less than 75mm (Fig. 3).

For RidgeFast bracket settings, see page 191. To establish the appropriate point at which to bend legs of ridge batten bracket and depth of ridge batten and depth of ridge batten (1 or 2 tiling battens) install short lengths of batten either side of the ridge, lay one or more tiles to both sides.

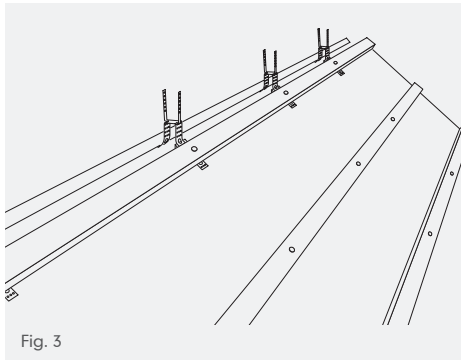

Fig. 3

Position a ridge tile on top, and check where the bracket legs need bending, and how many thicknesses of batten are required to ensure that a minimum of 20 mm screw penetration can be achieved.

- 3 Place the ridge batten(s) along length of ridge between the perforated straps of ridge batten brackets. Bend over the straps and nail each securely to the ridge batten using the nails supplied. Joints in ridge batten should be made half way across a ridge batten bracket to ensure the ends are secured (Fig. 4).

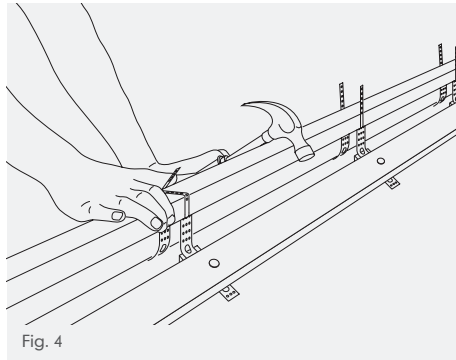

Fig. 4

It is recommended that the ridge batten is finished at either end of the ridge, a little beyond the outer edge of gable end tiles. This will allow for trimming back in accordance with requirements of the chosen ridge end treatment.

Where a bedded verge is used the ridge batten should be cut back 25mm to 50mm back from the face of the undercloak with cut ends treated with a suitable timber treatment. With the ridge batten(s) secured to the ridge batten brackets at each rafter, lay and fix the roof tiles in the normal manner.

UNIVERSAL RIDGEFAST SYSTEM

4 Unroll RidgeFast roll centrally along entire length of ridge batten and fix at approximately 2 metre centres to ridge batten using felt nails. Overlap roll ends by 100mm at each joint. At gable ends, roll should be able to lap over the edge of gable tile/verge finish by approximately 50mm (where a bedded verge is used it should be cut back by 50mm) (Fig. 5).

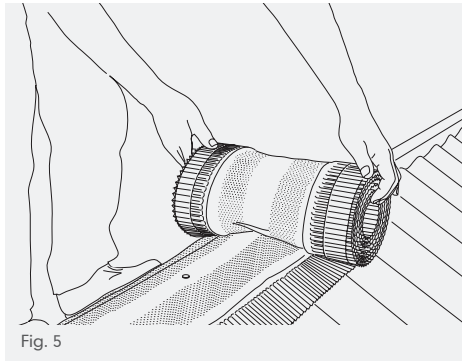

Fig. 5

5 Remove release paper covering the butyl strip on underside of corrugations on one side of the roof only. The other side should be released for one or two ridge tiles at a time to avoid foot traffic on the tiles.

Ensure area of top course tiles to which RidgeFast roll is to be adhered is dry and clean before proceeding (Fig. 6).

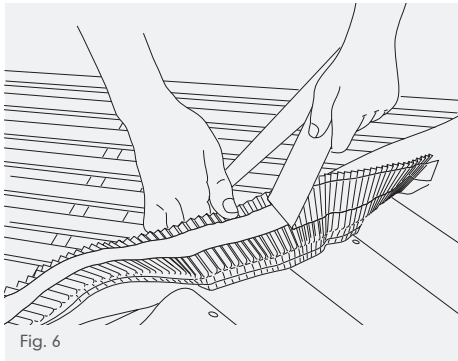

Fig. 6

6 Firmly press corrugations onto tiles on both sides along length of the ridge. With profiled tiles, it is best to adhere butyl to the top of profile either side of tile pan first, to ensure an even spread of corrugated strip across roof (Fig. 7).

7 Lay first ridge tile in correct relative position to gable end and secure to ridge batten, either directly through ridge tile with appropriate fixing, or through ridge end cap.

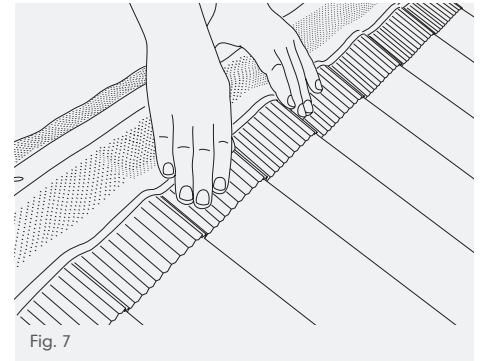

Fig. 7

UNIVERSAL RIDGEFAST SYSTEM

Select a ridge union, a union clamp and 75mm x 4.8mm s/s screw. Fit a union clamp into the central slot in the ridge union and offer up the assembly into the open end of the ridge tile so that it is trapped between the clamp and the union flange. Ensure it is centrally aligned with the ridge batten. Where the ends of the union overlap the edges of the ridge tile, cut off or fold inward, the excess length along the crease lines at

either end (Fig. 8). Engage the next ridge tile so that it is trapped between the union clamp and ridge union flange.

- 8 When the union clamp is fully engaged in the ridge union, it may create an interference fit with the sub-structure. In this case, the protruding length of the clamp can be snapped off or folded below the ridge union flange (Fig. 9).

- 9 Push ridge tile firmly into position and secure ridge union assembly to ridge batten by fixing screw through hole in union clamp using a pozidrive No. 2 screw bit (Fig. 10).

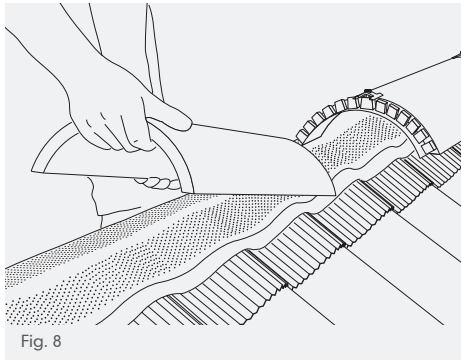

Fig. 8

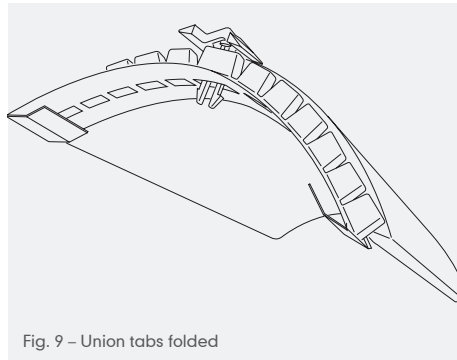

Fig. 9 – Union tabs folded

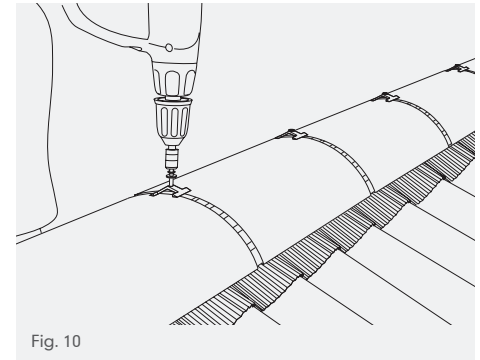

Fig. 10

UNIVERSAL RIDGEFAST SYSTEM

10 Repeat this process along ridge line, ensuring screws are not over-tightened. The ridge line should be finished with a full-length ridge tile. The minimum length of any cut ridge tile should be $\frac{1}{3}$ of a ridge or 150mm whichever is less (Fig.11).

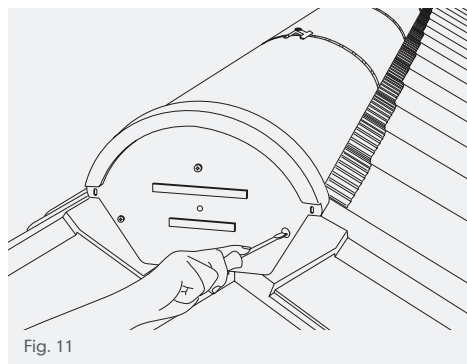

Fig. 11

UNIVERSAL RIDGEFAST WITH LINCOLN
When using Lincoln clay interlocking tiles with 375mm clay half round ridges, a 375mm clay ridge end tile, which is pre-holed for fixing, should be used at the gable ends (Fig. 12).

100mm x 4.8mm screw packs for deep ridges should be used for fixing the union clamps.

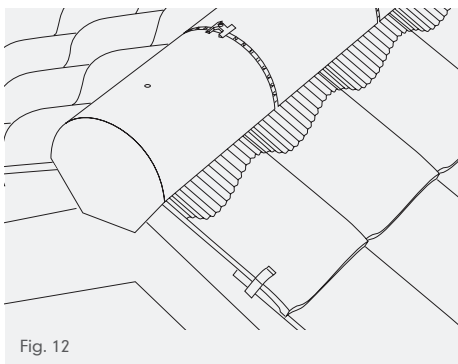

Fig. 12

UNIVERSAL RIDGEFAST SYSTEM

INSTALLATION WITH VENTILATED RIDGE TERMINAL/GAS VENT RIDGE TERMINAL

For both applications, ensure the ridge is covered with segmental ridge tiles to facilitate the fixing of the ridge union clamp.

Where a ridge vent terminal is installed at the ridge it will be necessary to either trim the ridge board or cut the ridge batten to allow the extension box to enter the roof void. Where a gas vent ridge terminal is used, ensure that all timbers are cut to provide a 25mm gap around the flue extension box.

To comply with Building Regulations it is necessary to prevent noxious gases and fumes from entering the roof void from the ridge terminal so the ventilation holes either side of the ridge roll need to be blanked off along a two metre length.

2 metre long x 75mm wide blanking strips available in the ridge vent terminal accessory pack should be used for this purpose.

Cut a hole in the RidgeFast roll to correspond with the position of the ridge vent terminal

extension box. Peel off the backing tape from the blanking strips and apply over the vent holes either side of the RidgeFast roll equidistant about the centre of the terminal. Fit the ridge union and adjacent ridge tiles in the normal manner.

It is recommended that the blanking strips are adhered to the RidgeFast roll on a flat even surface prior to offering to the roof. This will help to provide a secure, even bond.

RIDGE ABUTMENTS

At an abutment, ensure the RidgeFast roll is turned up the wall by 75mm, with the end ridge tile drilled and screw fixed. A Code 4/5 lead saddle should be fitted over the ridge tile in accordance with LSTA recommendations.

JUNCTIONS

At ridge/hip junctions, the ridge batten should be cut 50mm beyond the apex of the hip rafters and the ridge. Turn down the RidgeFast roll over the top of the roof tiles on the hip end by 75mm. A code 4/5 lead saddle should be fitted between the

RidgeFast roll and the ridge/hip tiles, with a welt formed along the edges under the ridge and hip tiles. The end ridge tile should be cut to a neat mitre with the hip tiles mechanically fixed (see gable end fixing).

Where an 'L shaped' junction occurs, ensure that the RidgeFast roll is lapped prior to the lead saddle being fitted. Form a welt along the edges of the lead saddle where it is fitted under the ridge and hip tiles. Mitre cut the end ridge tiles prior to fixing with screws and washers.

Where a 'T shaped' ridge junction occurs, or where a dormer ridge intersects the main roof, the RidgeFast construction should not cross the valley. A lead saddle (Code 4/5) should be fitted prior to the roof tiles being laid. The RidgeFast roll should be rolled out along the head of the T shape, with the corrugated edge stuck to the surface of the lead saddle (Code 4/5). The RidgeFast roll on the leg of the 'T' shaped junction or dormer intersection, should finish 50mm back from the face of any mortar bedding. The end ridge tile should be mechanically fixed.

UNIVERSAL RIDGE ROLL FOR SLATES

A simple and rapidly installed dry fix system providing 5mm continuous ridge ventilation. Compatible with fibre cement and natural slates when using fibre cement ridges.

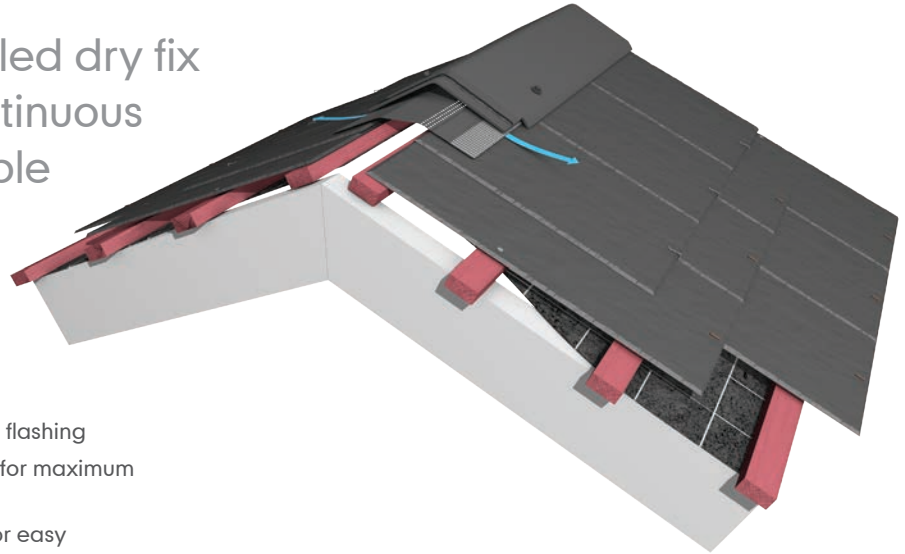

COMPONENTS

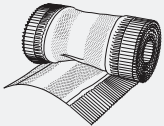

Universal
Ridge Roll (6m)
(390mm wide)

(code 33010)

Also available:
60mm x 14 gauge
self-tapping screws

- ▲ Highest grade aluminium flashing
- ▲ Hydrophobic membrane for maximum weather resistance
- ▲ Elastomeric membrane for easy installation and to prevent rucking
- ▲ Maintenance free
- ▲ Can be used for ridges and hips
- ▲ Completely dry fixed system
- ▲ Provides 5mm continuous ventilation along the ridge

UNIVERSAL RIDGE ROLL FOR SLATES

INSTALLATION

- 1 Lay the underlay along the ridge apex of the roof ensuring a 5mm clear air gap is maintained between the top edges.
- 2 Fix the top course slate batten to suit the gauge of the slate size being used and fix an additional ridge fix batten downslope to enable the 60mm x 6.3mm self-sealing wood screw fixings to penetrate the ridge unit 50mm from its bottom edge.
- 3 Head nail the top course slates to the top battens either side of the ridge apex, ensuring a 5mm clear gap is maintained between the top edges.
- 4 Unroll a 6 metre length of fibre cement slate ridge roll centrally along the length of the ridge apex. (At gable ends the roll should overlap the gable end by approximately 50mm or in the case of a mortar bedded verge cut back 50mm from the gable).
- 5 Remove the release paper covering the mastic strip on the underside of the corrugations on both sides of the roll and press the corrugations onto the top course slates either side of the ridge line.

IMPORTANT: Ensure the area of slates onto which the mastic strips will be adhering is thoroughly dry and dust free.
- 6 Repeat this process along the entire length of ridge overlapping the roll ends by 100mm at each joint.

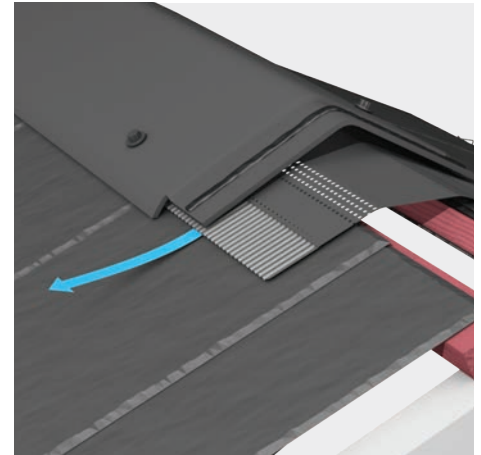
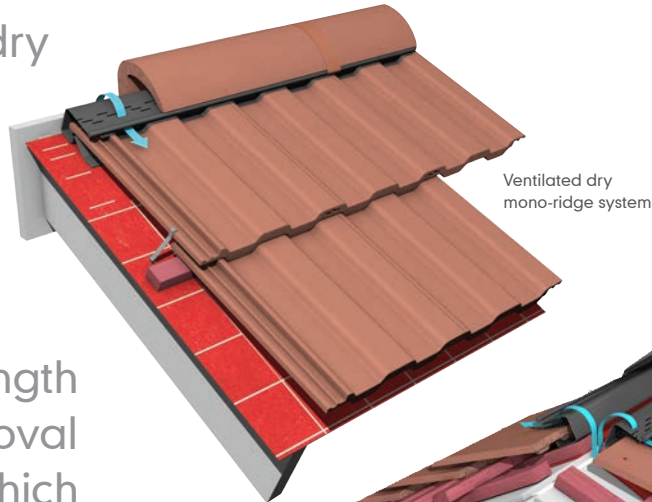

Fig. 1 – Universal Ridge Roll

VENTILATED DRY RIDGE AND DRY MONO-RIDGE SYSTEM

The Marley ventilated dry ridge system remains one of the simplest, aesthetically pleasing and effective means of providing continuous ventilation along the length of the ridge for the removal of stagnant, moist air which would otherwise be trapped in the roof apex.



Ventilated dry
mono-ridge system

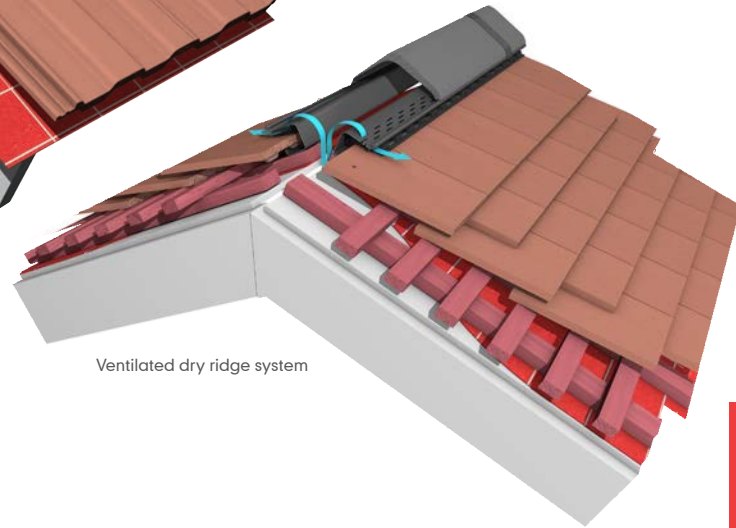

Ventilated dry ridge system



VENTILATED DRY RIDGE SYSTEM

COMPONENTS

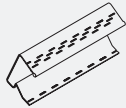

High profile batten section (3m long)

for Mendip, Wessex, Double Roman, Anglia (code 41201)

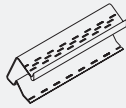

Low profile batten section (3m long)

for Modern, Duo Modern, Ludlow Major, Ludlow Plus, Edgemere range and Ashmore (code 41101)

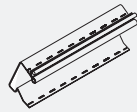

Steep pitch high profile batten section 45-55° (3m long)

for Mendip, Wessex, Double Roman, Anglia (code 41202)

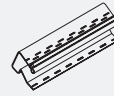

Steep pitch low profile batten section 45-55° (3m long)

for Modern, Duo Modern, Ludlow Major, Ludlow Plus, Edgemere range and Ashmore (code 41102)



Modern ridge junction apex cap

(code 440*)



Segmental ridge junction apex cap

(code 439*)



Modern ridge union

(code 414*)



Segmental ridge union

(code 413*)



Segmental mono-ridge union

(code 423*)



Modern/Segmental ridge adaptor union

(code 420*)

Vented filler units

Double Roman (code 42105)

Modern/Edgemere/Ashmore (code 41501)

Ludlow Major (code 41601)

Ludlow Plus (code 41508)

Mendip (code 41701)

Wessex (code 41901)

Anglia (code 41506)

Fibre cement slate (code 41705)

Dry ridge fixing kit

Kit contains:
16 No. nails, 2 No. H sections, 2 No. screws (code 4100)

Top course clip and nail pack

(Modern/Duo Modern code 30273
Edgemere range code 30297)

* Use colour code suffix: 01 - Grey, 03 - Brown, 04 - Terracotta.

VENTILATED DRY RIDGE SYSTEM

INTERLOCKING TILES INSTALLATION

- 1 Cut batten section with a hacksaw with ends of sections at joints meeting halfway over a rafter, so each end can be nailed (Fig. 1).
- 2 Provide overhang of 55/60mm (dependent on unit) at verges to allow fitting of top course Marley interlocking dry verge unit and end caps.
- 3 Use a ridge tile for setting out the batten sections to ensure they are the required distance to suit ridge tile and positioned equidistantly apart.

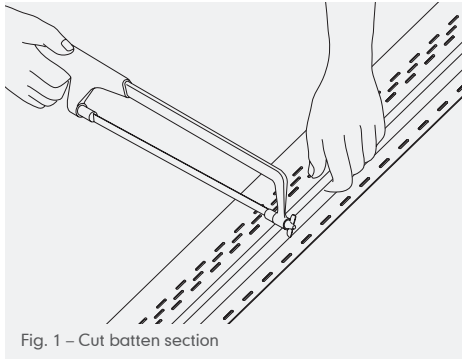

- 4 Free ends of batten section can be restrained by fixing an additional batten either side directly below the flange or the dry ridge batten section. This gives a second mechanical fix for the ridge unions. Figs. 2 and 3).
- 5 Nail batten sections to each rafter, taking care gauge position is constantly checked.
- 6 Join batten section over a rafter and clip an 'H' section piece, provided in the fixing kit, over top flanges before nailing.

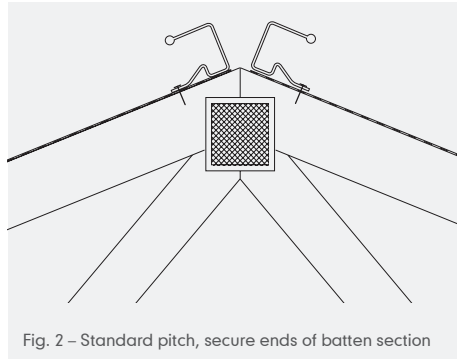

Wherever possible, stagger joints on opposite sides of roof. Underlay must be cut or set down from the apex to allow free passage to and from roof space below (Fig. 4).

Note: Allow no less than a 5mm gap between each 3m length of batten section. Form fire breaks where necessary and fill the space beneath the ridge tile spanning the party wall with suitable non-combustible material.

- 7 Place appropriate ridge filler unit onto head of tile.

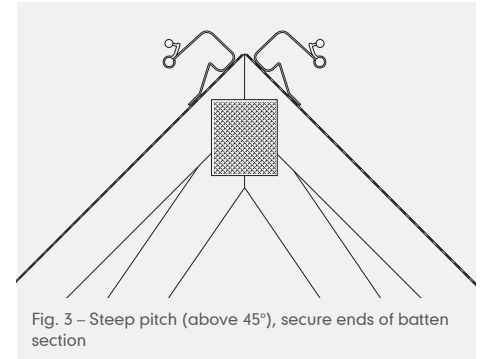

VENTILATED DRY RIDGE SYSTEM

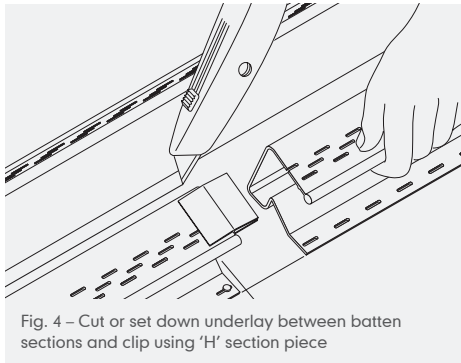

Fig. 4 - Cut or set down underlay between batten sections and clip using 'H' section piece

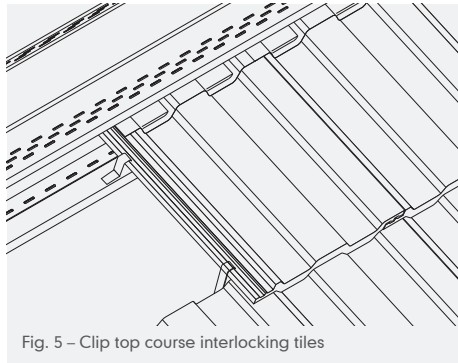

Fig. 5 - Clip top course interlocking tiles

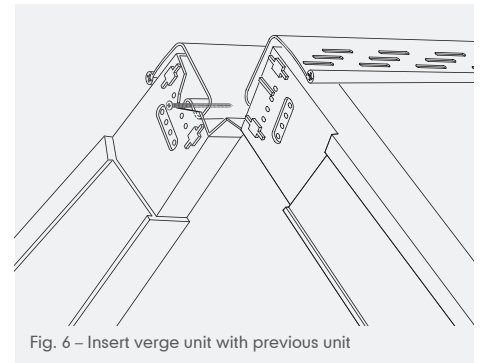

Fig. 6 - Insert verge unit with previous unit

- 8 Insert tile with filler unit into batten section by lifting top flange slightly until ribs engage over upstand and tile is held securely. The ridge filler unit for Modern has raised lugs which fit beneath circular beads on batten sections (Fig. 5).
- 9 Ensure each tile is mechanically fixed by using a standard tile clip located over side lock and nailed to top edge of second course tiling batten (Fig. 5).

- 10 Secure to top of interlock of all top course tiles where they are located into dry ridge batten section. Nail eaves clip to a timber batten fixed directly below lower flange of batten section, ensuring clip locates over sidelock.

- 11 Complete verges.

- 12 For the Marley Universal dry verge system, top course verge unit is retained by inserting a screw into second series of

holes in verge unit and locating unit behind mid-section of dry ridge batten, to avoid the dry verge units slipping down until the end cap is fixed in place. (Fig. 6)

- 13 For bedded verges, cut back lower flange of each dry ridge batten by approx. 50mm.

Lay undercloak under flange and bed tiles in normal manner (Fig. 7).

VENTILATED DRY RIDGE SYSTEM

14 For bedded verges, cut back lower flange of each dry ridge batten by approx. 50mm.

Lay undercloak under flange and bed tiles in normal manner (Fig. 7).

15 Where a PVC end cap is used (Fig. 8), screw Ridge end cap to end of Marley dry ridge batten, locating stainless steel screws (supplied in fixing kit) in end of circular beads on upper flange (Fig. 8).

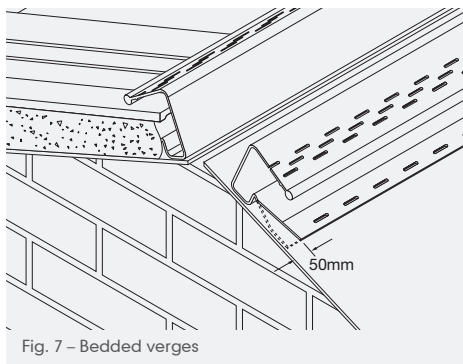

Fig. 7 – Bedded verges

16 When fixing with fibre cement slates, use a standard dry verge end cap to suit ridge profile, but cut lower flange along visible guide line on inside to reduce effective overhang (Fig. 9).

17 Cut lower flange across width (Fig. 9a) where necessary, to avoid interference with dry verge units on steeper roofs.

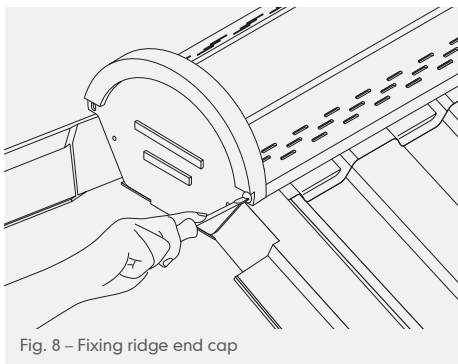

Fig. 8 – Fixing ridge end cap

18 Lay ridge tiles with each leg sitting on top of circular bead, with a gap of 3mm approx. between each ridge tile. This allows clearance for internal lugs of ridge union.

19 Fit ridge union by clipping each end over circular beads (Fig. 10, page 204).

Fix any cut ridge tiles adjacent to full end ridge tiles.

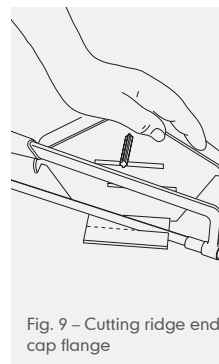

Fig. 9 – Cutting ridge end cap flange

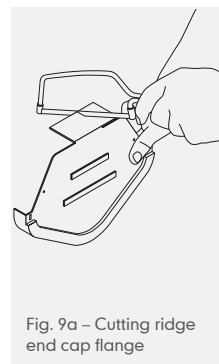

Fig. 9a – Cutting ridge end cap flange

VENTILATED DRY RIDGE SYSTEM

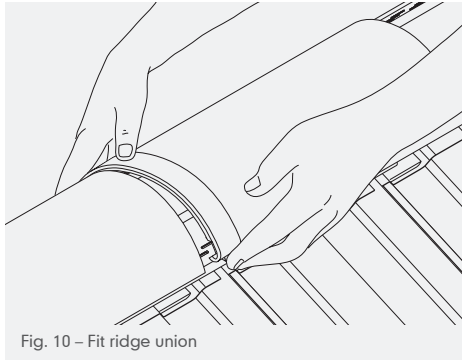

Fig. 10 – Fit ridge union

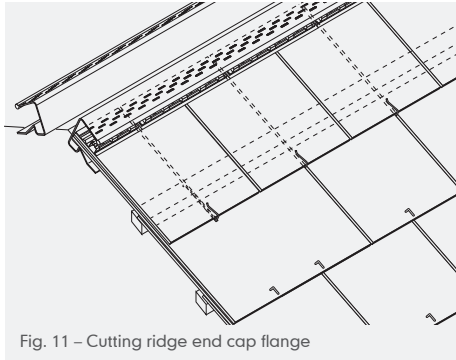

Fig. 11 – Cutting ridge end cap flange

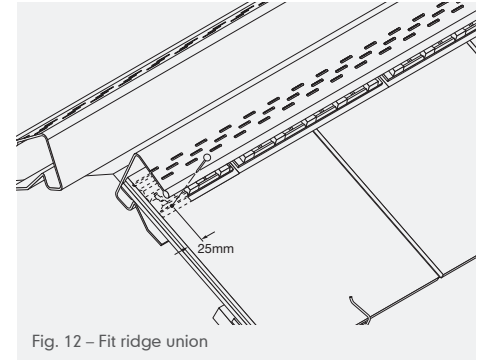

Fig. 12 – Fit ridge union

FIBRE CEMENT SLATE INSTALLATION

- 1 Lay slates up to dry ridge batten so back edge of top full length slate engages into batten section.
- 2 Centre nail to top batten in normal way.
- 3 For slate-and-a-half abutting verge, cut a 3mm wide slot parallel to verge from the head of slate down to point where leading edge of top course slate will be (Fig. 11).
- 4 Make slot a half slate width in from verge to allow for hook fixing standard width slate above.
- 5 Drive slate hook into top timber batten between each full length slate (provided by others).
- 6 Slide top course slates (cut to length) into place so leading edges are retained centrally by slate hooks.
- 7 Back edge of top course slates should touch inside edge of ridge batten section.
- 8 Place ridge filler units in position, trapped between top slate and top edge of batten section, butted together along length of ridge.
- 9 For mortar bedded verges, hips and valleys drill a 4mm diameter hole through top two courses as shown (Fig. 12) 25mm from verge and insert a copper slate nail.
- 10 Ridge filler unit should cover nail head, preventing internal movement of top course slate.

VENTILATED DRY MONO-RIDGE SYSTEM

MONO-RIDGE INSTALLATION

- 1 Use a mono-ridge tile to ensure the correct positioning of the batten section as required for the roof pitch.
- 2 Continue to install dry ridge system.
- 3 Complete all verges (see Marley Universal dry verge fixing instructions) and fit segmental mono-dry ridge end cap, if required.
- 4 Lay mono-ridge tiles with front leg sitting on top of circular bead with a gap of approximately 3mm between each tile to allow clearance for locating tongues of mono-ridge union.
- 5 Fit ridge unions by clipping front end over circular bead of batten section, followed by back end over bottom edge of mono-ridge tile (Fig. 13).
- 6 At gables, install full length mono-ridge and cut adjacent ridge to length as required. Cut ridge tiles should be no less than 150mm in length.
- 7 Mechanically fix each mono-ridge union by using a 25mm x 10 gauge stainless steel screw (supplied with ridge tile) fixed to a timber fascia behind vertical leg (Fig. 14).

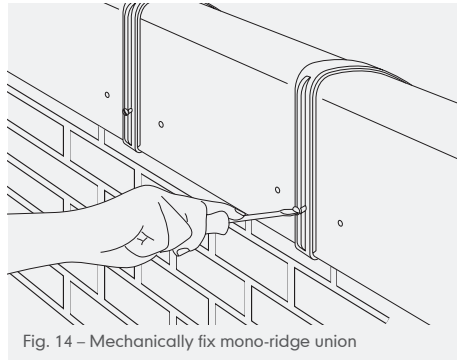
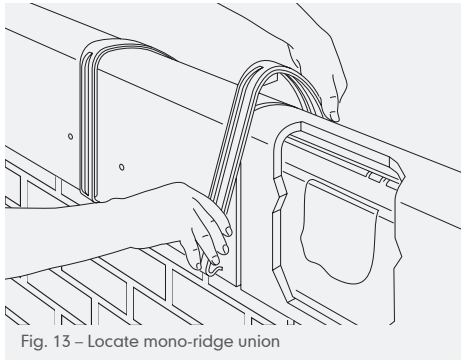

RIDGE VENT TERMINALS

Provides mechanical or passive stack ventilation.

COMPONENTS

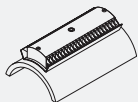

Ridge vent terminal

For natural ventilation of the roof void apex and connection to mechanical ventilation systems.

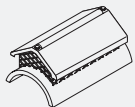

Gas vent ridge vent terminal

For connection to gas appliances of rated input of 60 Kw max. only (not suitable for gas condensing boilers or oil fired boilers.)

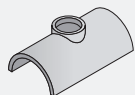

Gas vent ridge terminal for condensing boilers

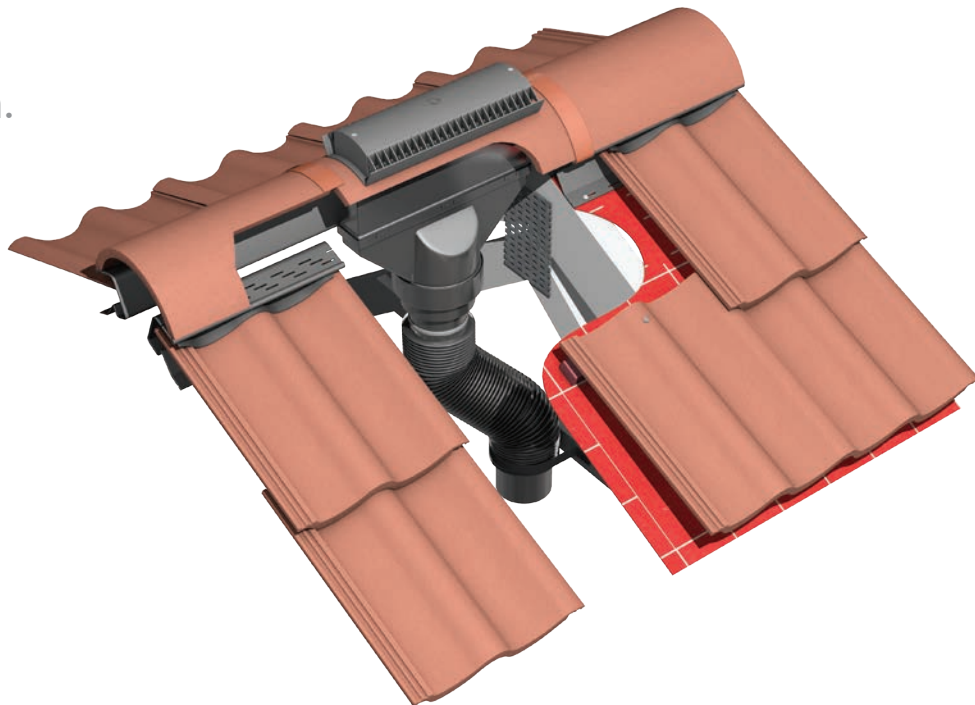

RIDGE VENT TERMINALS

GENERAL INSTALLATION GUIDANCE

Marley ridge ventilation terminals should be installed in a horizontal position clear of any obstructions which may hinder the airflow of exhaust fumes. Terminals must be positioned as follows:

- Gas vent ridge – min. 300mm apart.
- Ridge vent – min. 600mm away from any Gas vent ridge terminal or flue outlet.

RIDGE BOARDS

If a ridge board is used, it should be cut away for a length of 400mm and if any rafters are to be cut, trimmers should be provided. The roofing underlay should be neatly cut to provide a close fit to the sides of the riser (with the gas vent ridge, the top batten and underlay cut a min. 25mm away from the riser).

Cutting the ridge board or rafters and adding trimmers is structural work and should only be carried out by a competent person to ensure compliance with the Building Regulations.

RIDGE TERMINALS

Marley ridge terminals can be bedded to the roof tiles in the normal manner or may be incorporated in the Marley dry ridge system. Where Modern ridge tiles are used in a dry ridge construction, special Modern/Segmental ridge adaptor units should be used to connect the terminals to the ridge tiles (dry ridge system only, not suitable for RidgeFast).

CONCRETE GAS VENT AND RIDGE VENT TERMINALS

- 1 Cut a slot in the back of the batten section to allow the terminal throat extension to clear the base of the section.
- 2 Seal the slots in the top flange of the batten section for a distance of 2000mm both sides of the ridge below the terminal using the RidgeFast blanking tape (Code 33001). This is to prevent the ingress of exhaust fumes from the terminal entering the roof space.

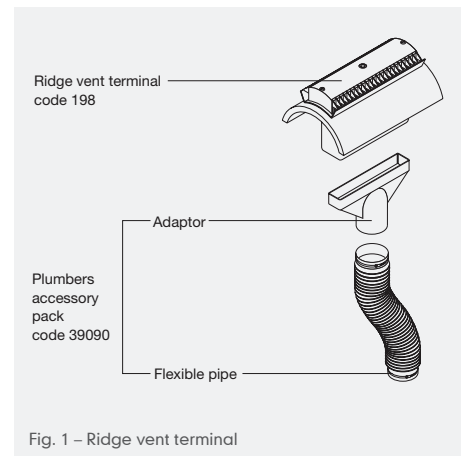

Fig. 1 – Ridge vent terminal

- 3 Mechanically fix the ridge vent terminal to the batten section using the appropriate Ridge Union. Where Modern ridge tiles are used, special Modern/Segmental Ridge Adaptor Units should be used to mechanically fix the terminals to the ridge batten section

RIDGE VENT TERMINALS

GAS VENT RIDGE TERMINAL

- 1 Connect flue using a metal 'R' type adaptor of suitable diameter, which is bolted to flange provided at base of throat extension (supplied by others).
- 2 Place gasket of suitable material between throat section extension and 'R' type adaptor and compress sufficiently, using bolts to form gas tight seal.

Throat extension allows easy connection of flue after ridge terminal has been installed.

- 3 Make provision to support flue pipe in accordance with requirements of BS 5440: Part 1.
- 4 Align exactly with ridge terminal to prevent undue stress at joints.
- 5 Do not hang unsupported flues from ridge terminal, or damage could occur to ridge terminal and adjacent tiling and seal between ridge tile and flue could be broken.

RIDGE VENT TERMINAL FOR ROOF SPACE VENTILATION

- 1 Install terminal in normal manner ensuring riser is kept free of all obstructions.

RIDGE VENT TERMINAL FOR MECHANICAL VENTILATION

- 1 The mechanical services engineer should connect the 110mm pipework.
- 2 Push flexible pipe over spigot end of adaptor and secure using jubilee clips.
- 3 Ensure that all ductwork is adequately supported to prevent strain being transmitted to ridge terminal.

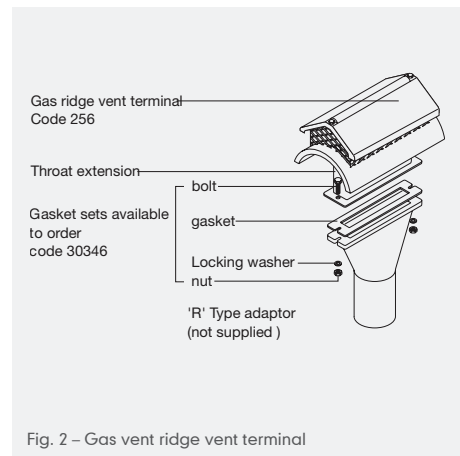
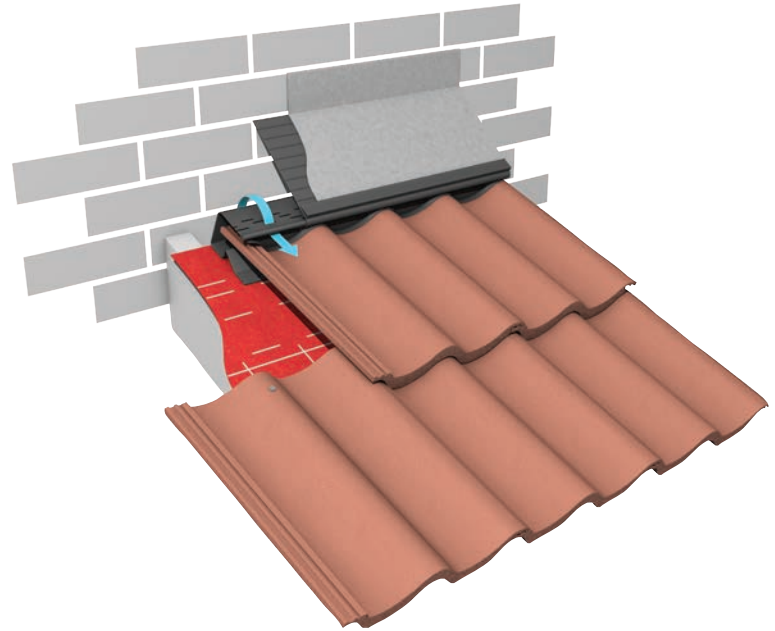

Fig. 2 – Gas vent ridge vent terminal

TOP ABUTMENT VENTILATION SYSTEM

The Marley top abutment ventilation system provides high level ventilation at the apex of lean-to roofs where they abut a vertical wall. Completely weatherproof, this continuous system provides eaves-to-apex ventilation when combined with the Marley eaves ventilation system.



TOP ABUTMENT VENTILATION SYSTEM

COMPONENTS

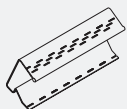

High profile batten section (3m long)

for Mendip, Wessex, Double Roman, Anglia (code 41201)

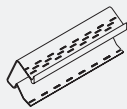

Low profile batten section (3m long)

for Modern, Duo Modern, Ludlow Major, Ludlow Plus, Edgemere range and Ashmore (code 41101)

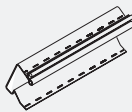

Steep pitch high profile batten section 45-55° (3m long)

for Mendip, Wessex, Double Roman, Anglia (code 41202)



Steep pitch low profile batten section 45-55° (3m long)

for Modern, Duo Modern, Ludlow Major, Ludlow Plus, Edgemere range and Ashmore (code 41102)

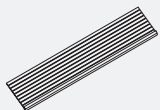

Abutment vent lead support strip (1.5m x 21.5cm)

(code 42505)

Vented filler units

Double Roman (code 42105)
Modern/Edgemere/Ashmore (code 41501)

Ludlow Major (code 41601)

Ludlow Plus (code 41508)

Mendip (code 41701)

Wessex (code 41901)

Anglia (code 41506)

Fibre cement slate (code 41705)



Fixing Kit

Kit contains:

16 No. Nails, 2 No. Screws,
2 No. 'H' Section

Sufficient to fix:
2 No. 3m lengths
(code 41000)

Top course clip and nail pack

Modern and Duo Modern
(code 30273)

Edgemere range
(code 30297)

Ashmore

TOP ABUTMENT VENTILATION SYSTEM

INSTALLATION

- 1 Felt and batten roof in normal way but do not return felt up abutment wall (Fig. 1).
- 2 A gap of 5mm to 10mm should be left to allow air flow from roof void.
- 3 Cut a small piece of lead support to use as a guide to setting out uPVC batten section. The top edge of the lead support strip should coincide with a mortar joint above line of tiling and leave a gap not less than 5mm between batten section and wall (Fig. 2).
- 4 Lead support should not be in contact with top flange of batten section, otherwise ventilation flow will be affected.

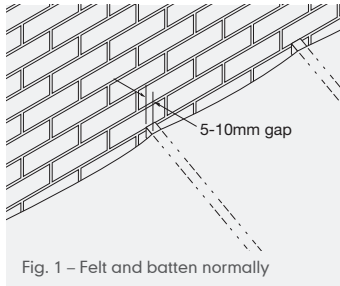

- 5 Roof is tiled in normal way and top course tiles/slates with their respective fillers fitted into batten section (Fig. 3).
- 6 Ensure each top course tile is clipped or each top course slate is secured by a hook.

INTERLOCKING TILES AND SLATES

- 1 Complete main roof tiling/slating in the normal manner Insert tile with filler unit into batten section by lifting top flange slightly until nibs engage over upstand and tile is held securely.

(The ridge filler unit for Modern has raised lugs which fit beneath circular beads on batten sections) (Fig. 3).

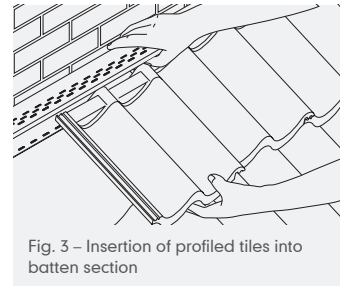
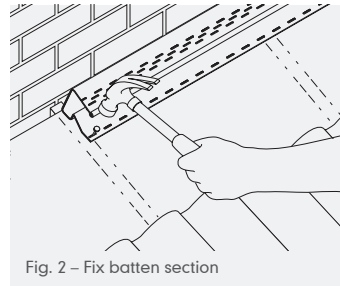

- 2 Ensure each tile is mechanically fixed by using a standard tile clip located over side lock and nailed to top edge of second course tiling batten.
- 3 Clip lead support strips to batten section so that top edge rests in mortar joint previously identified (Fig. 4).
- 4 A gap of about 5mm should be left between successive lengths of lead support to allow for thermal expansion.
- 5 Dress Code 4 lead or similar flashing material, over lead support strip and fit front edge into integrated retaining channel on front edge support (Fig. 5, page 212).

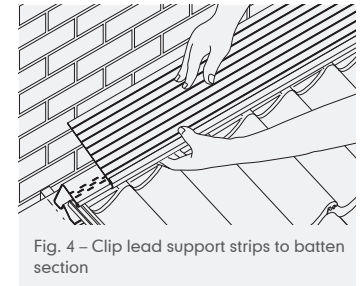

TOP ABUTMENT VENTILATION SYSTEM

- 6 Wedge hip edge of lead into mortar joint as required by the LSTA.
 - 7 Ensure laps are staggered to support the unit.
 - 8 At verge, dress lead flashing down over verge, turn around corner of wall and secure in a mortar joint with lead wedges.
- 3 For slate-and-a-half abutting verge, cut a 3mm wide slot parallel to verge from the head of slate down to point where leading edge of top course slate will be (Fig. 6).
 - 4 Make slot a half slate width in from verge to allow for hook fixing standard width slate above.
 - 5 Drive slate hook into top timber batten between each full length slate (provided by others).
 - 6 Slide top course slates (cut to length) into place so leading edges are retained centrally by slate hooks.

- 7 Back edge of top course slates should touch inside edge of ridge batten section.
- 8 Place ridge filler units in position, trapped between top slate and top edge of batten section, butted together along length of ridge.
- 9 For mortar bedded verges, hips and valleys drill a 4mm diameter hole through top two courses as shown (Fig. 7) 25mm from verge and insert a copper slate nail.
- 10 Ridge filler unit should cover nail head, preventing internal movement of top course slate.

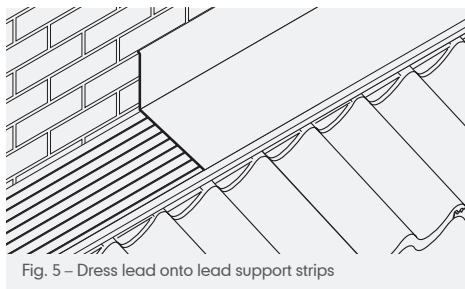

Fig. 5 – Dress lead onto lead support strips

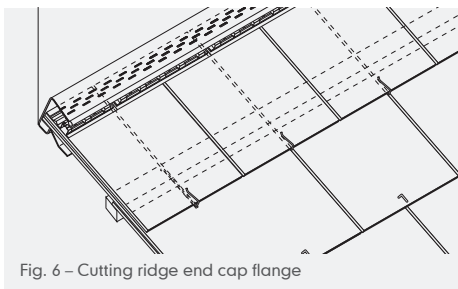

Fig. 6 – Cutting ridge end cap flange

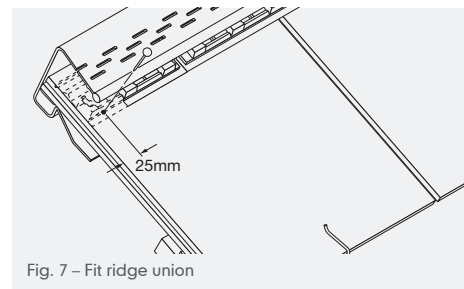

Fig. 7 – Fit ridge union

INDIVIDUAL DRY SOAKERS

The Marley range of individual dry soakers are an easy to install, lightweight and cost effective way to reduce both the material and labour costs associated with lead at side abutments.

Manufactured from a high density and high performance polypropylene, the dry soaker range offers excellent thermal stability, and resistance to UV light, acid rain and cracking under temperature change.

For full details on the use of lead soakers and weatherings, please see pages 24-31.

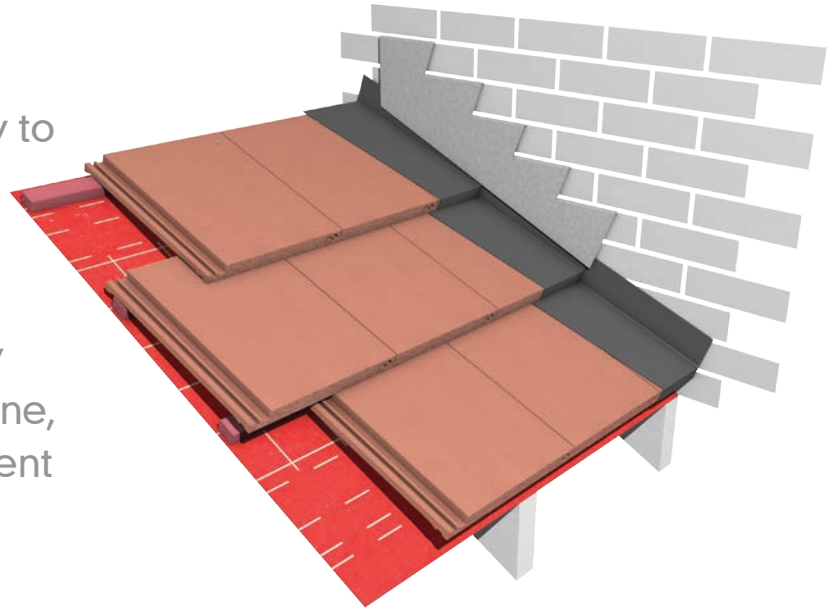

INDIVIDUAL DRY SOAKERS

COMPONENTS

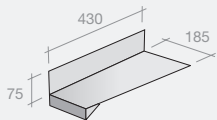

Modern
interlocking tiles
dry soaker

(LH code 30476)
(RH code 30477)

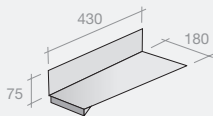

Edgemere
interlocking tiles
dry soaker

(LH code 30474)
(RH code 30475)

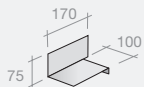

Clay or concrete
plain tiles
dry soaker

(LH code 30478)
(RH code 30479)

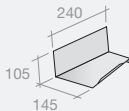

Ashmore
interlocking tiles
dry soaker

(LH code 30472)
(RH code 30473)

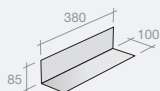

Fibre cement slates
dry soaker
(For both left and right
hand code 30480)

GENERAL INSTALLATION

- 1 Turn roofing underlay up at the abutment so that the top edge is covered by the flashing by no less than 50mm.
- 2 Fit battens leaving a small gap to the abutment.

EDGEMERE AND MODERN TILES

- 1 Push fit the soakers on to the tiles and lay the tiles along the abutment in the normal manner.
- 2 When all soakers are installed, the preformed 75mm upstand can be covered using a stepped lead flashing in the traditional manner (Fig. 1).

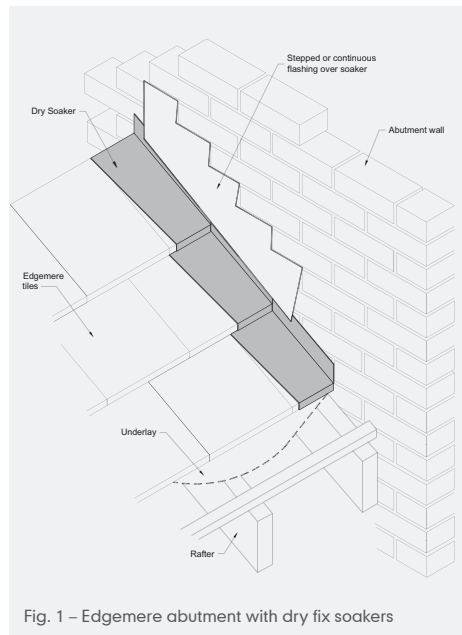
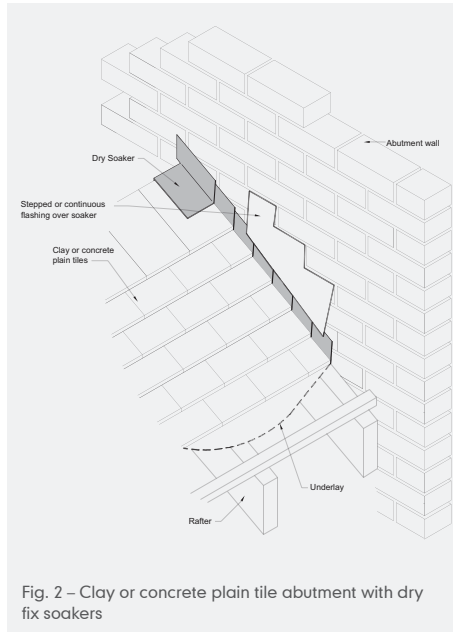

Fig. 1 – Edgemere abutment with dry fix soakers

INDIVIDUAL DRY SOAKERS

CLAY OR CONCRETE PLAIN TILES

- 1 Plain tile soakers are laid on top of each consecutive abutment tile with the 90° turndown locating over the head of the tile, the weight of the following courses of tiles keeping the soaker in position against the abutment (Fig. 2).
- 2 The 75mm upstand can be covered using a traditional lead flashing.



INDIVIDUAL DRY SOAKERS

ASHMORE TILES (FIG. 3)

- 1 Install Ashmore tile soakers with the 90° turn-down locating over the rear of the tiling battens – beneath each tile. Install Ashmore abutment tiles over each consecutive soaker unit – the weight of the tiles keeping the soakers in position against the abutment.
- 2 The 105mm upstand can be covered using a traditional lead flashing.

FIBRE CEMENT SLATES (FIG. 4)

- 1 Suitable for use with fibre cement 600mm x 300mm slates. Laid in conjunction with appropriate abutment slates and nailed into position with the slate in accordance with BS 5534.
- 2 The finished soaker upstand can be covered using a traditional lead flashing.

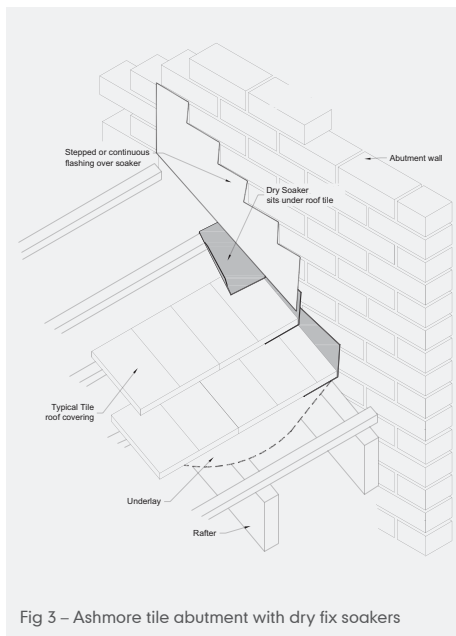

Fig 3 – Ashmore tile abutment with dry fix soakers

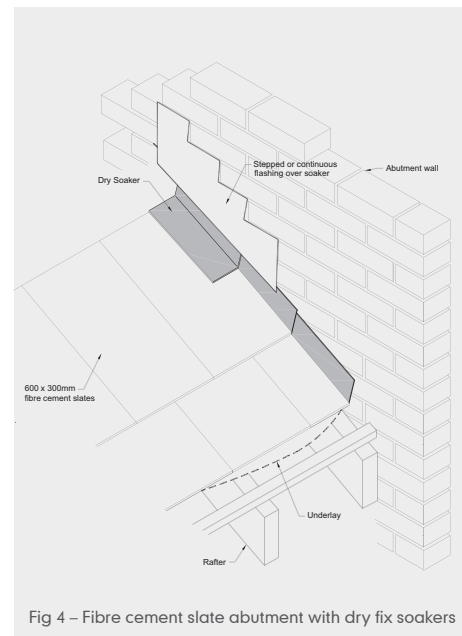

Fig 4 – Fibre cement slate abutment with dry fix soakers

FLEXFAST LEAD REPLACEMENT ROLL

The FlexFast Lead Replacement Roll has been developed as a time saving solution that doesn't require specialist fitting skills. It has excellent aesthetics and rigidity while also being easy and quick to install.



COMPONENTS

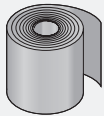

FlexFast lead replacement roll

Available in 5m x 300mm rolls (code 42610)
or 5m x 450mm rolls (code 42611).

Butyl tape (code 42612), mastic (code 42614)
and trims (code 42613) are also available.

FLEXFAST LEAD REPLACEMENT ROLL

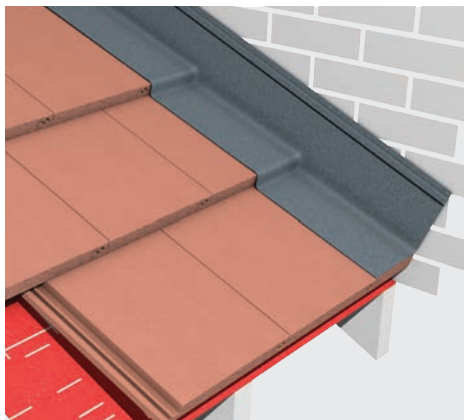

COVERAGE

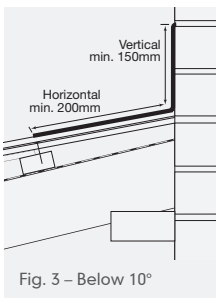
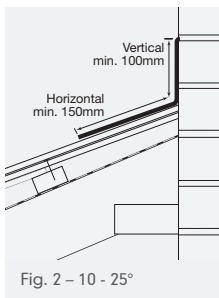
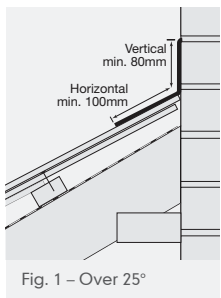

JOINTS

Top layer > 100mm cover

Bottom layer > 25mm return

Fold over bottom layer by min. 25mm to create a welt joint.

ADHESION

Within contours of tiles, ensure min. contact adhesion of 50mm.

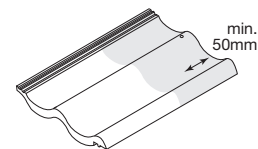

FLEXFAST LEAD REPLACEMENT ROLL

CHIMNEY FLASHING

The following steps describe how to use Universal lead replacement roll to form a typical chimney flashing. The universal lead replacement roll can also be used to form other types of flashings including saddles for hips and valleys.

1 The first step in making a chimney flashing is the fitting at the eaves section. This should be at least 30cm longer than the chimney is wide (Fig. 1).

2 Fold the fitting lengthwise in the centre, then fold its edges around both sides of the chimney, keeping it upright. This creates a continuous material edge that prevents leakages. Shape the material using scissors or a cutter. Cut the sides along the front of the chimney and the water-conducting surface of the roofing material, so there is approximately 3cm left on each side. Connect the two cutting lines where they meet, forming a smooth curve (Fig. 2).

Then remove the protective film and shape the wall and chimney flashing tape to the roof covering material.

Because it can be stretched by up to 60%, it can also be easily shaped against more grooved shingles or tiles.

3 Now, partially remove the protective film. Fold the 2cm overlap evenly over the corner on the eaves side, creating a frictional connection. One simple fold suffices (Fig. 3).

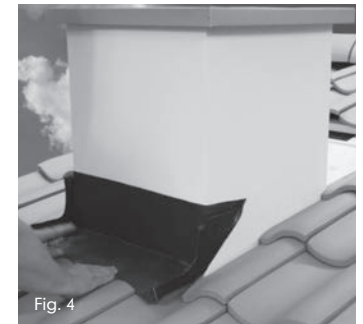
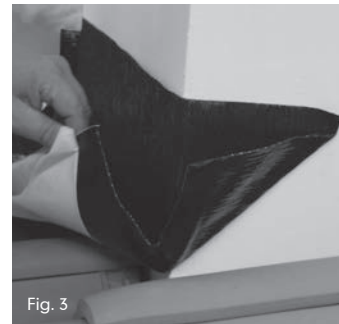
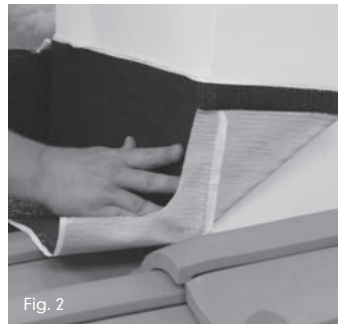

FLEXFAST LEAD REPLACEMENT ROLL

- 4 When adhering the fitting, make sure to start from the inner edge and work outwards (Fig. 4). This prevents large air pockets from forming. If there is no intact interlocking joint on the roofing material at the chimney, dress over the adjacent roof tiles by no less than 150mm.
- 5 Attach the ridge-side connection to the previously created roof valley framing (Fig. 5). The cut piece here is the same length as on the eaves side. Depending on the roof slope and appearance, a double fitting or 450mm wide tape may be necessary.
- 6 Before covering the roof tiles or shingles, also fold the ridge-side fitting approximately 5cm over to create a connection to the roofing (Fig 6.).

The Universal lead replacement roll allows you to quickly, easily and securely create a stable chimney flashing. Since it can be stretched by up to 60%, the material is easy to use for virtually any application.
- 7 Aluminium trims are the finishing touch. Adjust these to the chimney width and roof slope and attach them to the chimney. Then seal with high quality, external grade waterproof sealant provided by others (Fig. 7).



Fig. 5



Fig. 6

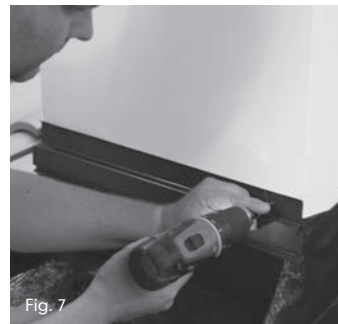

Fig. 7

ROOF DEFENCE

A fire-resistant barrier below the roof and ridge tiles – and above the party walls or spandrel panels below the roof covering – which separate different properties within roof spaces or provide lines of compartmentation, typically in attached or terraced housing.

Roof Defence is manufactured from low smoke zero halogen, highly intumescent flexible material.



COMPONENTS

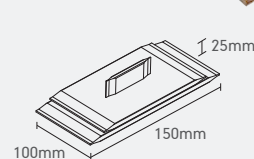

Roof Defence Intumescent Ridge Cap
(code MA68010)

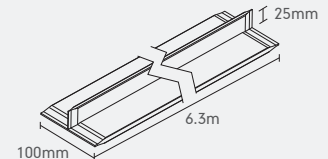

Roof Defence Intumescent Fire Barrier
6.3m (code MA68020)

ROOF DEFENCE

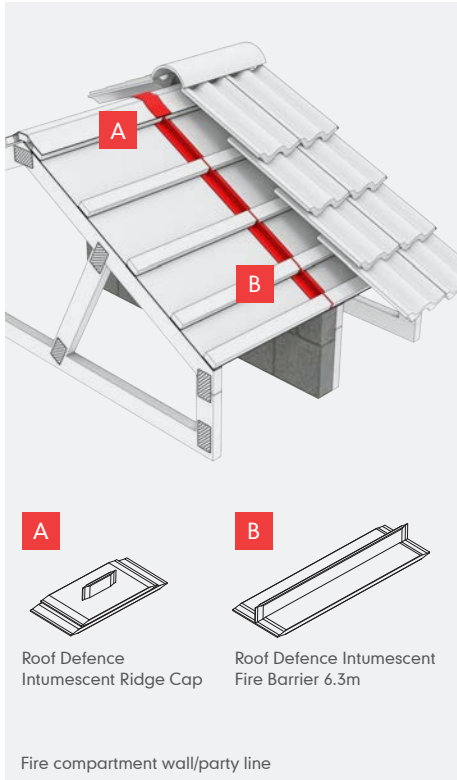

DESCRIPTION

Each Roof Defence Roll, is 6.3m long x 100mm wide x 6mm thick with an upstand (forming an inverted T shape) 25mm high x 4mm thick. Suitable for maximum 96mm gaps between wall head (above the breather membrane) and the highest point of roof tile profile (to the underside of the tile).

Each Roof Defence Ridge, is formed with a T shaped profile, similar to the roll above, typically measuring 150mm long x 100mm wide x 4mm thick, or 50mm long x 25mm wide x 4mm thick, the ridge section is also provided with an additional flat section measuring 200mm long x 100mm wide by 4mm thick.

BEFORE ORDERING

Roof Defence Roll and Ridge section are designed to be used in conjunction with appropriately fire rated spandrel panels / masonry walls and non combustible roof tiles only.

The system selected should be confirmed as being approved with the persons responsible for design, for example the architect and or the fire engineer.

GENERAL PREPARATION

1 Roof Intumescent Fire Barrier Roll must be installed in a continuous band across the roof, following the party wall (compartmentation) line.

The correct positioning should be confirmed with the project designer or specifier.

- Any joints that need to be formed between rolls must be overlapped (see step 2, page 224).
- The party wall/spandrel panel/ compartment wall should be constructed with the appropriate fire resistance rating required and the head of the wall should be completed in a flat plane in line with the timber truss/rafters either side of the wall.
- Roof Defence Intumescent Ridge Cap must be installed in a continuous line across the ridge, following the party wall and or compartmentation line.

The correct positioning should be confirmed with the project designer or specifier.

ROOF DEFENCE

FIXING TO TIMBER

Staples - When fixing directly into timber substrates with T50 staples, a minimum 12mm and maximum 14mm long stainless-steel staples should be used.

Screws - When fixing directly into timber substrates with screws, stainless steel screws should be used. The diameter of the screw head should be a minimum of 10mm and a maximum width of 11.5mm. The length of the screw should be a minimum of 25mm.

Nails - Nail guns may be used, however the firing pressure should be carefully controlled to ensure that the stainless steel nail (head minimum diameter 10mm and maximum 11.5mm) does not push through the 6mm fire barrier. The nail should be a minimum of 25mm long.

FIXING TO MASONRY

When fixing into masonry, self-tapping stainless steel screws should be used. The diameter of the screw head should be a minimum of 10mm and a maximum width of 11.5mm. The length of the screw should be a minimum of 25mm.

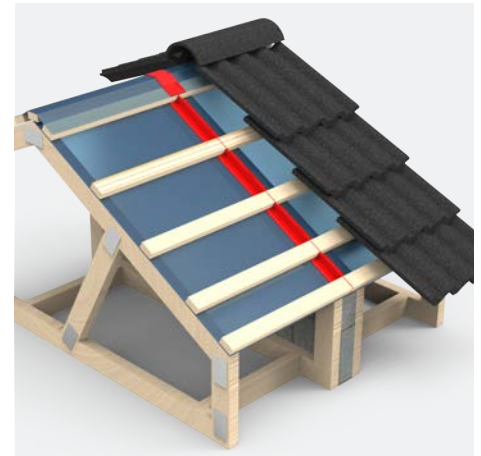
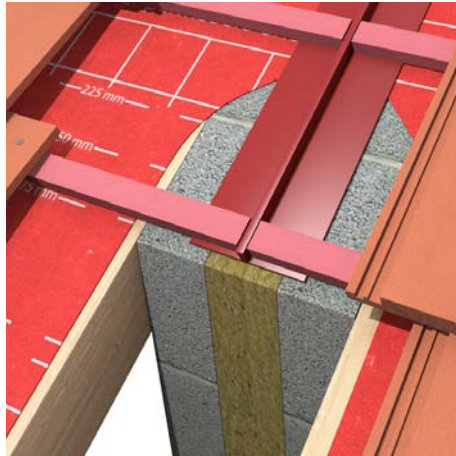

ROOF DEFENCE

ROLL INSTALLATION

- 1 Fix the breather membrane into position as required.

The top of the spandrel panel or brick/block wall should be completed in a flat plane, in line with the top of the roof truss/rafters.

- 2 The Roof Defence roll should be placed over the breather membrane, freely facing upwards, with the 100mm flat side positioned centrally on the centre line of

the party/compartiment wall/spandrel panel (forming the line of compartmentation) separating the properties or compartments.

Any joints made must be overlapped by a minimum of 25mm so that the intumescent material is continuous across the roof compartmentation line. This can be achieved by cutting the plastic sleeve between the flat section and the inverted T upstand, taking care not to damage the intumescent strip.

Cut at least 25mm of the intersection of the plastic sleeve and fold the upstand back. Overlap the flat section of the fire barrier with the adjoining section of fire barrier. Fold the inverted T section back into its central position and staple the upstands to each other.

The sleeve covering the fire barrier may be left open ended where it may have been cut to suit the installation.

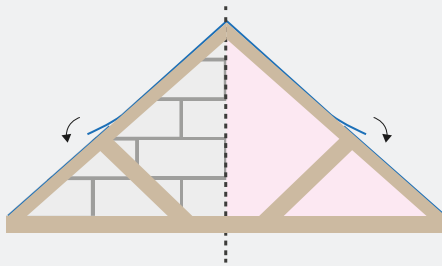

Fig. 1 – Follow plane of roof

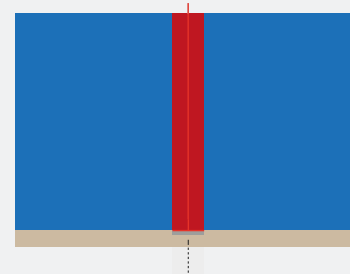

Fig. 2 – Place over breather membrane/underlay

ROOF DEFENCE

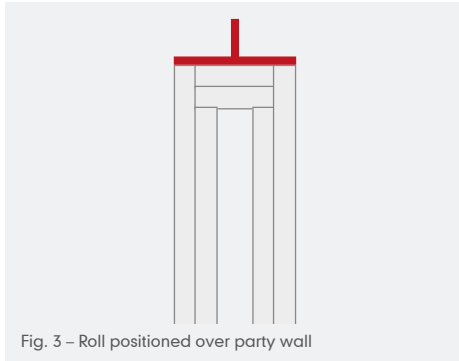

Fig. 3 – Roll positioned over party wall

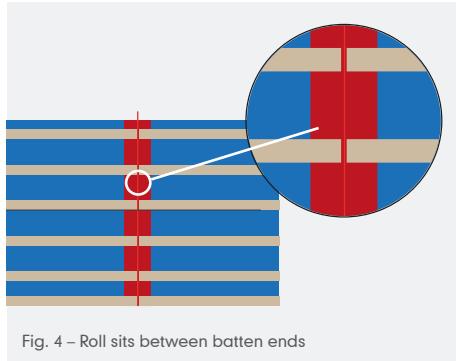

Fig. 4 – Roll sits between batten ends

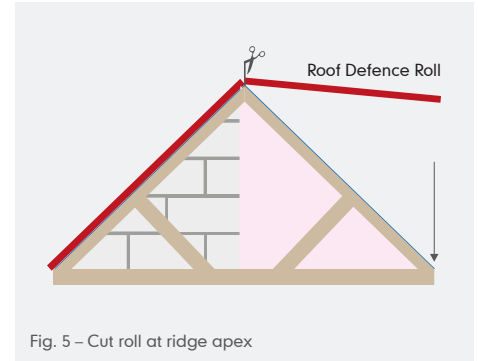

Fig. 5 – Cut roll at ridge apex

- 3 The 25mm vertical upright of the fire barrier should stand upright and be positioned on the centre line between where the roof tile battens will be fixed, again on the centre line of the party wall/spandrel panel separating the line of compartmentation.

The Roof Defence Roll will sit between and beneath the roof tile battens.

Note: The Roof Defence fire barrier, should be installed in such a way that ensures the fire barrier is not interrupted. Roof tile battens should not interrupt the fire barrier, roof tile battens must be cut either side of the fire barrier.

- 4 Where the Roof Defence Roll passes over the ridge, the 25mm upstand will require cutting at the apex of the ridge to allow the roll to continue down the other side of the roof.
- 5 Roof Defence Ridge may be fixed permanently into position prior to the fixing of the roof tile battens. The barrier should as a minimum be fixed within

500mm of the ridge and 500mm from the lower edge of the roof, with a maximum of 1 metre distance between all intermediate fixing points.

Fit and fix roof tile battens, either side of the fire barrier, as per required roof fixing details. All battens can be fixed through the ridge section, if required.

ROOF DEFENCE

- 6 Fit roof tiles as per required details, but do not fit ridge tiles.
- 7 Fit ridge timbers as per manufacturer's instructions ensuring that a 5mm gap is left between the ridge batten associated with the ridge details.

Alternatively, fit one side of the ridge timbers, to one side of the compartment line and attach the shorter part of the T (25mm by 4mm thick) section of the ridge cap to the end of the ridge timber. Ensure that the ridge cap is positioned centrally to the ridge batten. Fit the adjoining ridge batten as required.

- 8 Wrap the remaining part of the ridge section (100mm wide by 150 long by 4mm thick) down the sides of the ridge battens and fix to the ridge battens.

Ensure that the second flat layer of roll is freely moving, not fixed down to the ridge timbers or battens and is only fixed at the centre to the wide/flat part of the inverted T strip below. This should be as it was supplied.

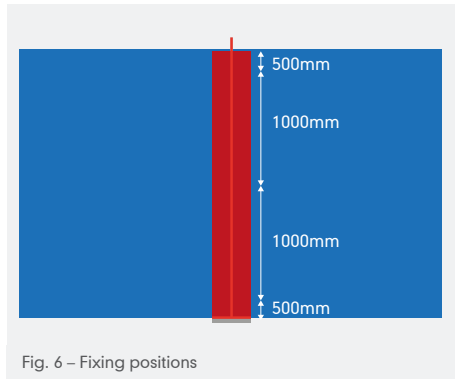

Fig. 6 – Fixing positions

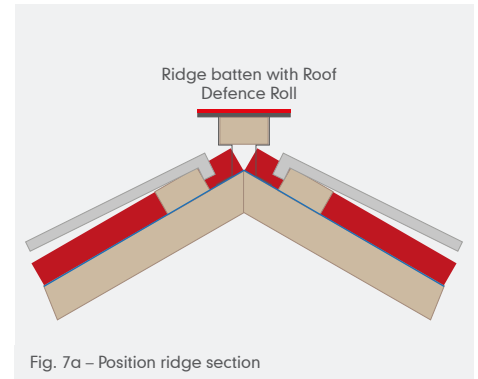

Fig. 7a – Position ridge section

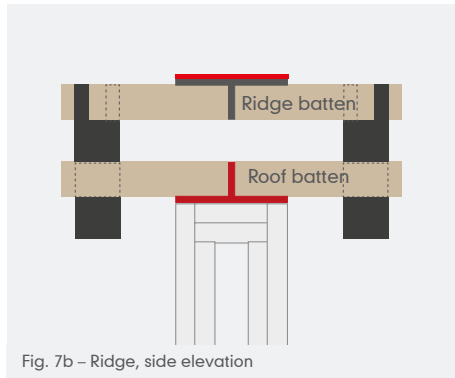

Fig. 7b – Ridge, side elevation

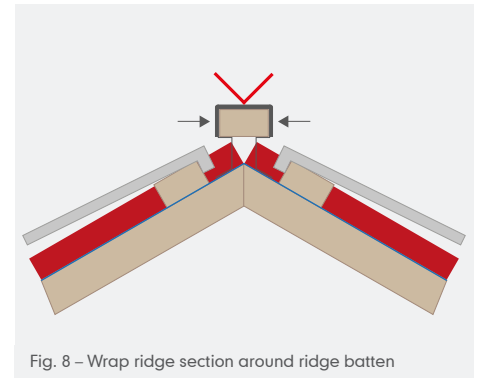
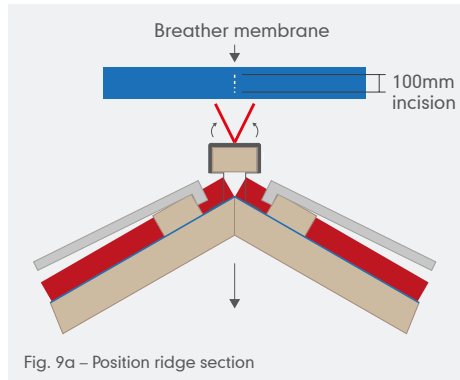
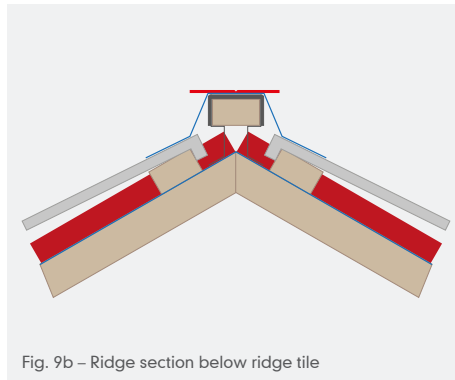

Fig. 8 – Wrap ridge section around ridge batten

ROOF DEFENCE



- 9 Fit ventilated ridge kit breather membrane as per manufacturer's instructions and make a 100mm incision longitudinally in the breather membrane (to the line of the ridge tiles) in line with the roll below, ensuring that the ridge section below is not cut.



Lift one side of the breather membrane and fold the two halves of the upper roll pad together and gently insert these two halves of the pad through the incision and then fold the ridge section down over the ridge kit breather membrane.

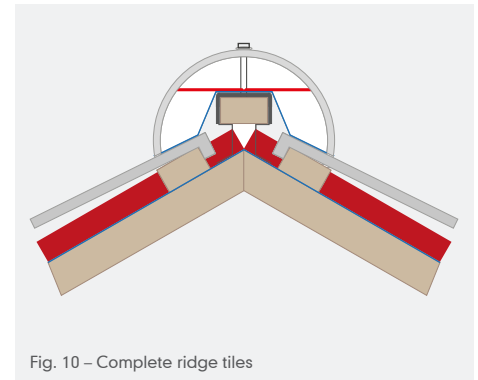

The upper strip of roll should now be sitting over the breather kit membrane in a position that will be beneath the ridge tile.

UNIVERSAL TILE VENT TERMINAL

The Universal tile vent is designed for roof void ventilation and connection to 110mm soil pipe or mechanical extract systems.

It is suitable for use with most popular large format and '15 x 9' concrete interlocking tile profiles at roof pitches 20° and above. Free area: 15,000mm².



UNIVERSAL TILE VENT TERMINAL

COMPONENTS

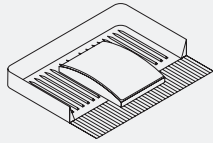

Universal tile vent
(code 36700)



Flexible pipe
(sold separately)

INSTALLATION

- 1 Lay underlay and batten the roof in the normal manner.
- 2 Lay roof tiles up to the desired position of the vent (ideally mid-span between rafters).
- 3 Form a 'V' shaped cut in the underlay, 270mm long x 140mm wide – aligned with the centre line of the overall width of the tile below – to correspond with the position of the tile vent spigot (Fig. 1).
- 4 Fold up and secure the underlay as shown (Fig. 2).
- 5 Place the tile vent into position centrally over the overall width of the tile below, ensuring the 'nib' is resting squarely against the back face of the tiling batten. Secure the vent tile by nailing through the slot in the 'nib' into the back face of the tiling batten using a 25mm long x 3mm dia. non-corrosive nail (galvanised steel, aluminium or stainless steel), Fig. 3.

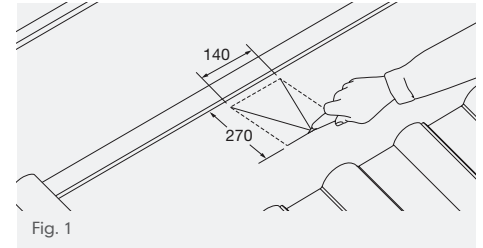

Fig. 1

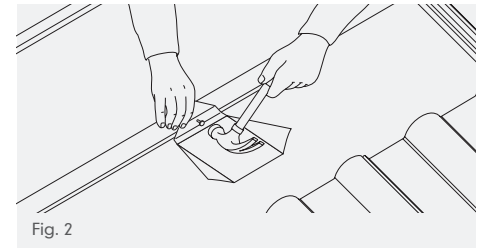

Fig. 2

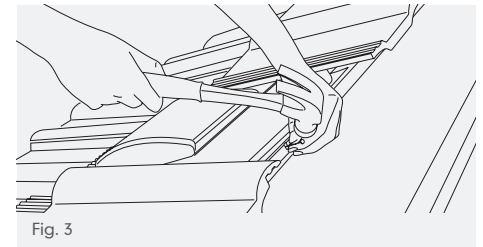

Fig. 3

UNIVERSAL TILE VENT TERMINAL

- 6 Peel off the release paper from the butyl along the underside leading edge of the corrugated flashing and press the flashing down evenly, ensuring a good seal against the tiles below. The surface of the tiles to which the butyl is adhered must be dry and free of dust (Fig. 4).
- 7 Finish tiling. The tiles immediately adjacent to the tile vent will compress the foam upstands creating a weatherproof seal. Ensure the cutaway in the back edge of the foam is laid over the lock of the adjacent right hand tile (Fig. 5).

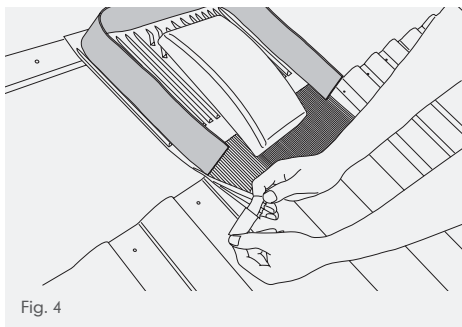

Fig. 4

- 8 Tail clip the left hand tile adjacent to the tile vent and the 3 tiles immediately above.

Note: When using '15 x 9' tiles, the underlock of the adjacent right hand tile may be removed to provide more space to accommodate the vent cap.

If the unit is to be used to ventilate the roof void, the circular spigot must be sawn off on site prior to installation to achieve the maximum designed ventilation area (Fig. 6). This product is not suitable as an exhaust for hot gases.

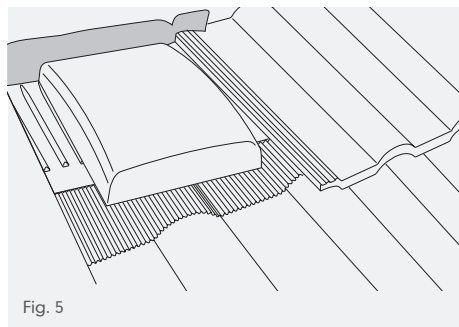

Fig. 5

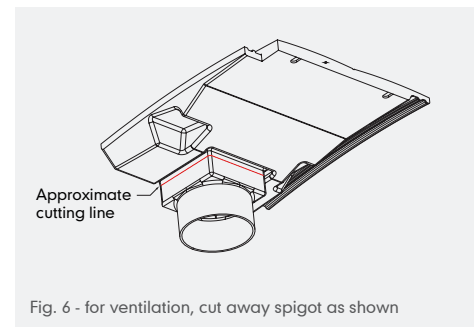

Fig. 6 - for ventilation, cut away spigot as shown

TILE VENT TERMINALS

For roof space ventilation, mechanical extract and soil vent pipes.

Tile vent terminals can be used for high or low level ventilation and are also designed for connection to mechanical extract ventilation systems and soil vent pipes.



TILE VENT TERMINALS

COMPONENTS

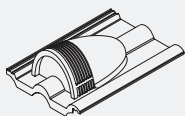

Double Roman*
Vent Terminal
(code 298)

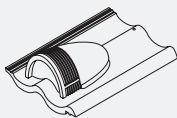

Mendip*
Vent Terminal
(code 294)

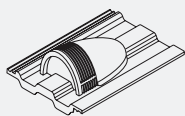

Ludlow Major*
Vent Terminal
(code 297)

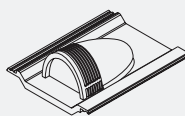

Wessex*
Vent Terminal
(code 296)

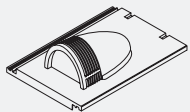

Modern*
Vent Terminal
(code 295)

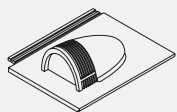

Edgemere*
Vent Terminal
(code 259)

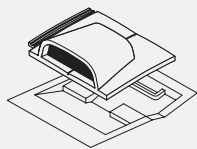

Ashmore ventilation†
roof tile and
catchment tray
(code 263)

* For mechanical extract and soil vent pipe installation use flexible pipe (code 39091).

† For roof ventilation only. Not suitable for mechanical extract and soil vent pipe installation.

PRESSURE RESISTANCE (PA)

Tile	Free area (mm ²)	Pa		
		15	30	60
Ashmore	4200	–	–	–
Double Roman	7614	6.5	24.8	89.1
Edgemere	7081	7.6	28.6	106.7
Ludlow Major	7665	6.7	24.3	88.4
Mendip	7107	7.6	27.9	101.7
Modern	7081	7.6	28.6	106.7
Wessex	6929	7.9	29.7	110.6

See also table on page 239.

TILE VENT TERMINALS

INSTALLATION

- 1 All tile vent terminals come with polystyrene packaging which also acts as a template. Place template flat onto underlay at desired position (Fig. 1).
- 2 Mark batten with corresponding arrows on template to assist setting out.
- 3 Remove lower course of tiles and place template flat onto underlay and mark outline of hole.
- 4 Carefully cut out a cross with a sharp knife.
- 5 Make a horizontal cut in the underlay, 390mm long, at a distance 150mm above bottom edge of tiling batten supporting vent tile (Fig. 2).
- 6 Slide soaker tray under batten and through slit in underlay.
- 7 Secure soaker tray by folding cut underlay over batten and nail into top edge of tiling batten above (Fig. 3).
- 8 Lay vent terminal ensuring that pipe enters hole cleanly and is fixed in accordance with required fixing specification.

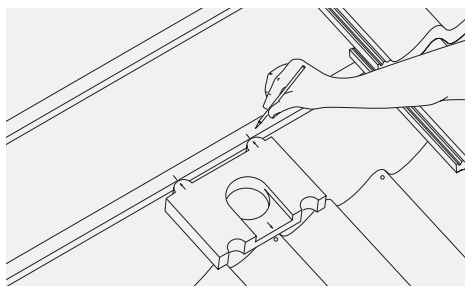

Fig. 1 – Mark position

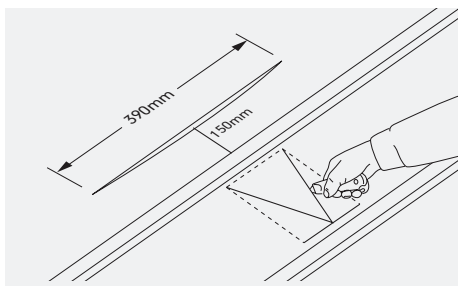

Fig. 2 – Make aperture in underlay

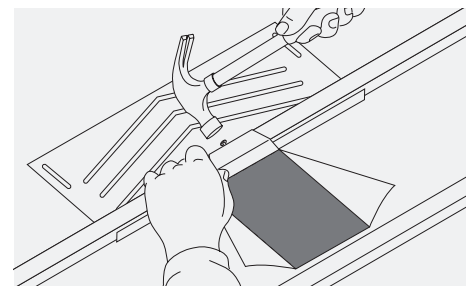

Fig. 3 – Cut and nail back underlay

9 Lay adjacent tiling in normal manner (Fig. 3).

For Tile vent terminal spacings, see page 250.

Note: Tile vent terminals may be used for termination of mechanical extract systems or soil vent pipes, but must be connected by a plumber. To avoid misalignment problems, connections to 110mm pipework should be carried out using a flexible pipe connector (Code 39091) and any long runs of pipework should be supported to avoid strain on the terminal.

To enable the completed pipework to be tested, the vent grille may be prised out of the concrete hood, to allow an inflatable bag to be used, and replaced later when testing is completed. Where the terminals are used for extraction of soil vent pipes they must not terminate lower than 900mm above any opening into a building within 3m.

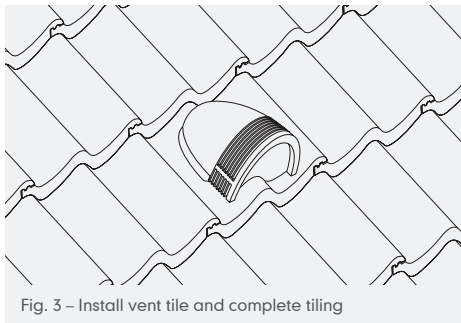

Fig. 3 - Install vent tile and complete tiling

TILE VENT TERMINALS

ASHMORE VENTILATION ROOF TILE

The Ashmore ventilation roof tile is designed to provide ventilation of the roof space, either at high or low level and have a colour-matched concrete hood with matt black aluminium grille. Incorporating a standard tile base, the terminal is simply substituted for a standard tile and fixed accordingly. Free area: 4,200mm².

- 1 Select a position for vent tile clear of rafters and lay catchment tray in position. Cut a 170mm gap in the batten to accommodate the catchment tray.
- 2 Mark airway aperture on underlay (Fig. 4).
- 3 Remove catchment tray and cut underlay back to tiling batten to form a flap which should be pulled up so there is a gap of approx. 6mm between underside of batten and underlay.
- 4 Nail flap to top of tiling batten (Fig. 5).
- 5 Lay ventilation tile over catchment tray and clip or nail, if necessary (Fig. 6).
- 6 Lay adjacent tiling in normal manner (Fig. 7).

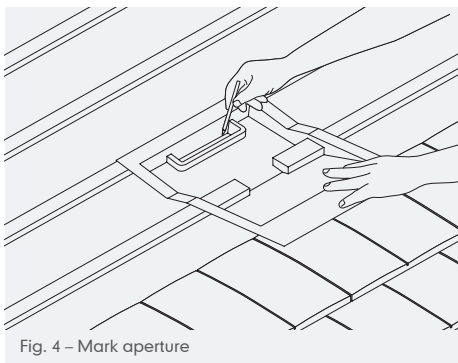

Fig. 4 - Mark aperture

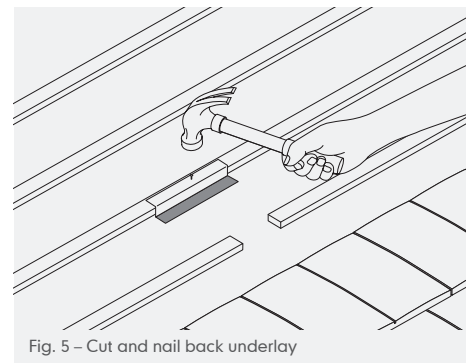

Fig. 5 - Cut and nail back underlay

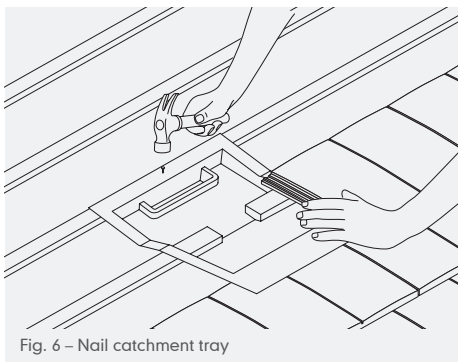

Fig. 6 - Nail catchment tray

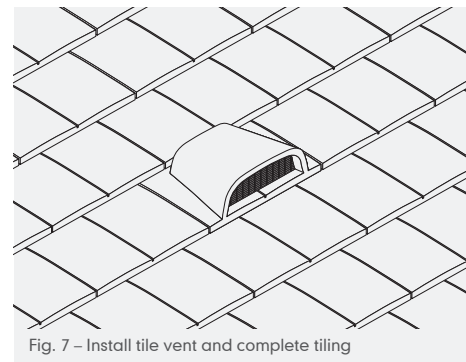
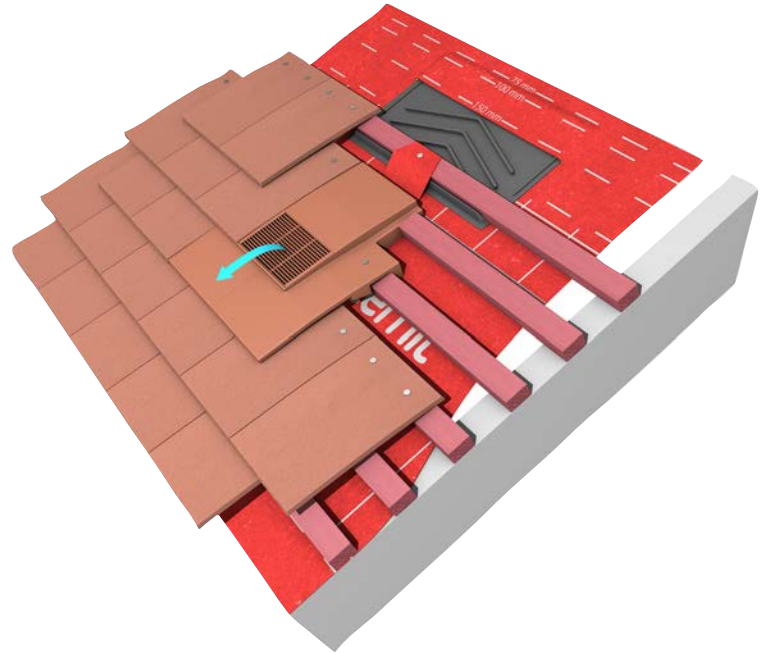

Fig. 7 - Install tile vent and complete tiling

CONTOUR TILE VENT TERMINALS

Offering an unequalled combination of performance and appearance, contour vent terminals are designed to provide ventilation of the roof space, either at high or low level for either mechanical extraction or soil vent pipes whilst retaining an uninterrupted roofscape.

Minimum roof pitch 22.5°
(except Plain tiles at 35°).



CONTOUR TILE VENT TERMINALS

COMPONENTS

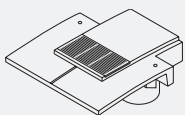

Universal Plain Tile
Contour Vent Terminal
(code 455)

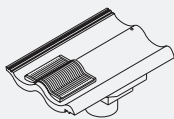

Mendip Contour
Vent Terminal
(code 452)

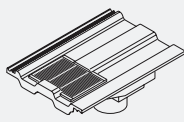

Ludlow Major
Contour Vent Terminal
(code 456)

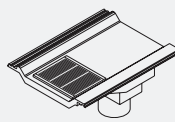

Wessex Contour
Vent Terminal
(code 459)

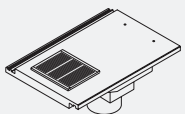

Modern Contour
Vent Terminal
(code 451)

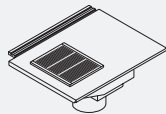

Edgemere Contour
Vent Terminal
(code 259)

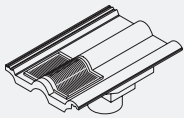

Double Roman
Contour Vent Terminal
(code 453)

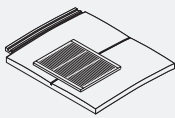

Ashmore Contour
Vent Terminal
(code 450)

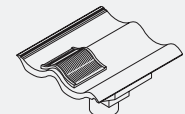

Anglia Contour
Vent Terminal
(code 453)

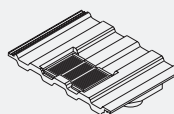

Ludlow Plus
Contour Vent Terminal
(code 457)

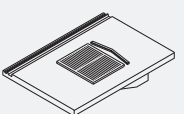

Edgemere
Contour Vent
Terminal*
(code MA475**)

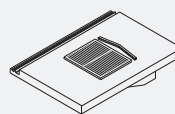

Modern
Contour Vent
Terminal*
(code MA461**)

* Adaptor sold separately ** Grey 01 - Brown 03 - Red 05 - Anthracite 08

INSTALLATION FOR ASHMORE, LUDLOW PLUS, PLAIN TILE AND ANGLIA

1 Felt and batten roof in normal manner.

Note: If unit is to be used as a roof void vent, circular spigot and 5mm of box section must be sawn off on site to achieve maximum designed free vent area.

2 Determine position of vent tile (ideally mid-span between rafters) and remove section(s) of tiling batten to accommodate unit.

3 Form 'V' cut in underlay in manner shown to accommodate rectangular spigot.

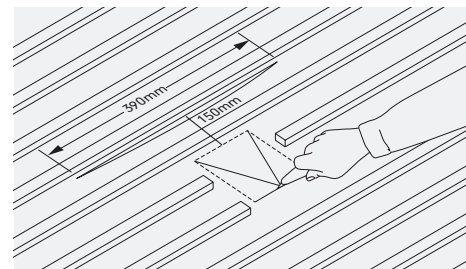

Fig. 1 - Make aperture in underlay. For Plain and Anglia tiles battens will need to be cut to create sufficient aperture

CONTOUR TILE VENT TERMINALS

- 4 Make a horizontal cut in underlay, 390mm long, at a distance 150mm above bottom edge of tiling batten above unit and slide soaker tray under batten and through slit in underlay (Fig. 1, page 237).
- 5 Secure soaker tray by folding cut underlay over batten and nail into bottom edge of tiling batten above (Fig. 2).
- 6 Insert tile unit and mechanically fix using screws provided (Fig. 3).
- 7 Continue tiling in normal manner.

INSTALLATION FOR LUDLOW MAJOR, EDGEMERE, MENDIP, MODERN, DOUBLE ROMAN, DUO MODERN, WESSEX.

- 1 Install underlay and battens in normal manner.

Note: If unit is to be used as a roof void vent, circular spigot and 5mm of box section must be sawn off on site to achieve designed free vent area.

- 2 Determine position of tile vent terminal (ideally mid-span between rafters) and form a 'V' cut in the underlay to accommodate box spigot (Fig. 4).

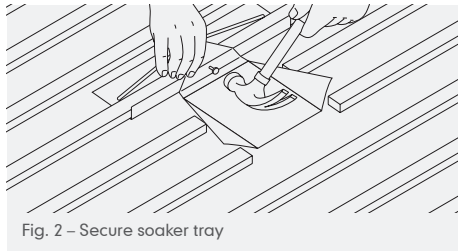

Fig. 2 – Secure soaker tray

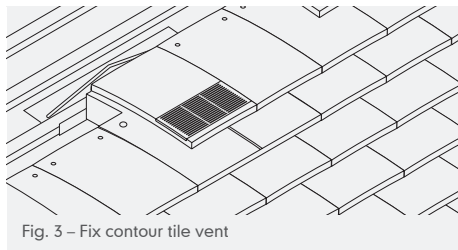

Fig. 3 – Fix contour tile vent

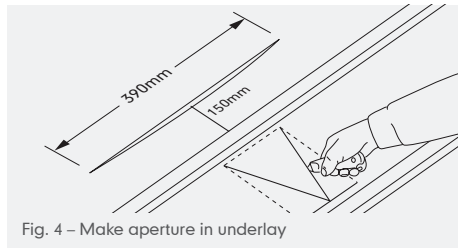

Fig. 4 – Make aperture in underlay

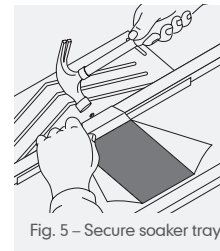

Fig. 5 – Secure soaker tray

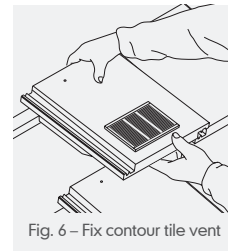

Fig. 6 – Fix contour tile vent

- 3 Make horizontal cut in underlay, 390mm long, at a distance 150mm above bottom edge of tiling batten, supporting vent tile and slide soaker tray under batten and through slit in underlay.
- 4 Secure soaker tray by folding cut underlay over the batten and nail into the top edge of the tiling batten above (Fig. 5).
- 5 Insert tile vent unit within main body of tiling and mechanically fix using standard tile clip fixings (Fig. 6).

Note: This product is not suitable as an exhaust for hot gases.

CLAY IN-LINE VENT TERMINAL

Available in a range of bases with real clay tile slips on the visible edge (2 tiles wide). The clay tile vent provides a net ventilation area of $6,100\text{mm}^2$ per vent. Suitable for natural, mechanical or soil pipe ventilation.

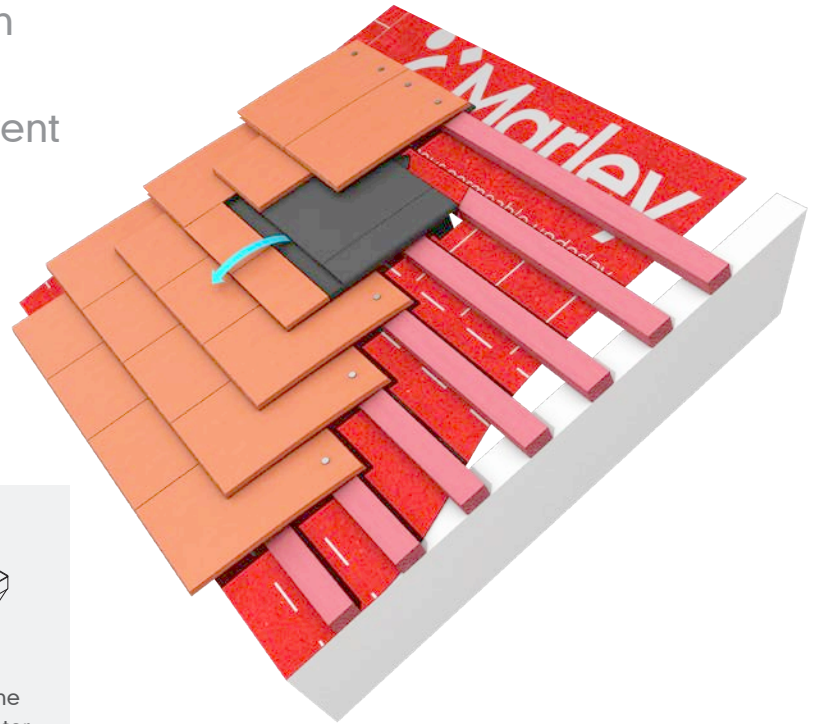

COMPONENTS

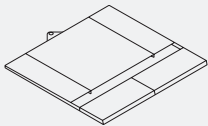

Clay in-line vent terminal



Flexible pipe
(sold separately)
(code 39091)

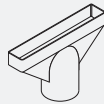

Clay in-line vent adaptor
(sold separately)

CLAY IN-LINE VENT TERMINAL

INSTALLATION

- 1 Fix the roof underlay, batten and tile in the normal manner.
- 2 At the position the ventilator is required, align the throat between two tile battens, and mark the throat position before cutting through the underlay as shown (Fig. 1).
- 3 Fold the three flaps upwards and outwards to provide the hole for the ventilator throat (Fig. 1).
- 4 Make a second horizontal cut 340mm wide in the underlay between the next two battens directly above the opening already created. Slide the underlay protector unit through the horizontal cut as shown (Fig. 2).
- 5 Insert the ventilator throat through the hole in the underlay into the roof space and position ventilator onto surrounding tiles. Fix to tile batten by the two side flanges using two nails ensuring half bond is maintained. Secure fixings are required to prevent the ventilator lifting when fitting pipe adaptor.

- 6 Continue tiling in the normal manner (Fig. 3).
- 7 For soil venting or mechanical extraction, attach pipe adaptor and flexible pipe (supplied separately) after installation of the ventilator.

Note: The ventilator is not suitable for the extraction of hot combustion gases.

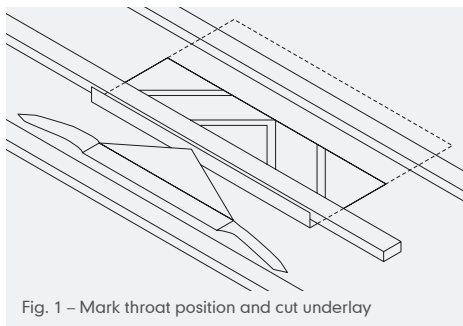

Fig. 1 - Mark throat position and cut underlay

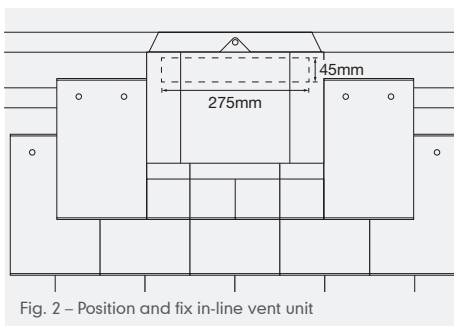

Fig. 2 - Position and fix in-line vent unit

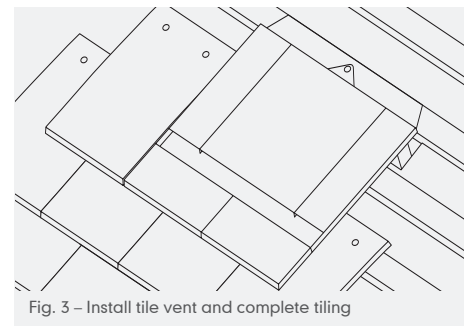
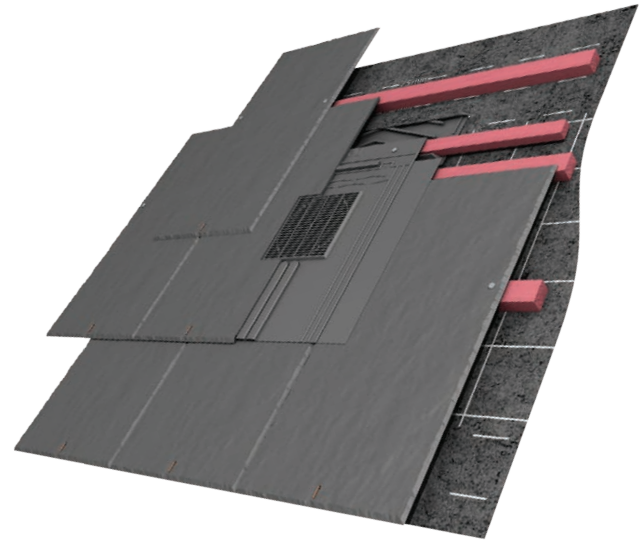

Fig. 3 - Install tile vent and complete tiling

IN-LINE SLATE VENTILATOR

Ideal for roof designs where the normal ventilation air path is blocked by valleys, hips, abutments, dormer windows and fire breaks or party walls, or where it is not possible to incorporate standard eaves or ridge ventilation. For 600 x 300mm slates only.



COMPONENTS

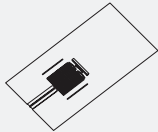

In-line slate ventilator*

(code EU_UNIVSLATEVENT)



Flexible pipe (sold separately)

(code 39091)

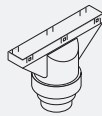

In-line slate vent adaptor (sold separately)

(code EU_INLINESLATEADAP)

* Minimum pitch 20°

- ▲ Fully integrates with the roof covering
- ▲ Ideal for natural, mechanical or soil pipe ventilation
- ▲ 10,000mm² free area of ventilation

PRESSURE RESISTANCE (PA)

Pa (litres/sec airflow)	15	30	60
10,000mm ² free area	10.9	41.5	162.0

IN-LINE SLATE VENTILATOR

- 1 Felt and batten the roof in the normal manner.
- 2 Determine the position of the ventilator, between rafters. Cut the slate directly below the ventilator so that it does not project past the slate batten to which it is secured.

Ensure that the bottom edge of slate vent aligns with bottom edge of adjacent slates.

Remove a 280mm section of batten to accommodate the unit. Form a 'V' cut in the underlay to accommodate the rectangular spigot (Fig. 12).

- 3 Secure an additional support batten 20mm above the cut batten. Cut a 354mm horizontal slit in the underlay 50mm – 60mm centrally above the additional support batten.

Slide the underlay protector tray above the additional support batten until the protector's upstand can be secured to the lower edge of this batten.

Nail the uppermost 'V' of the underlay to the rear of the additional support batten (Fig. 13).

- 4 Position the In-line slate ventilator centrally on the slate coursing below and level with adjacent slates. Drill two 5mm holes in the ventilator, ensuring adequate clearance to accommodate the copper disc rivet shanks for securing the tail of the overlapping slates (Fig. 14).

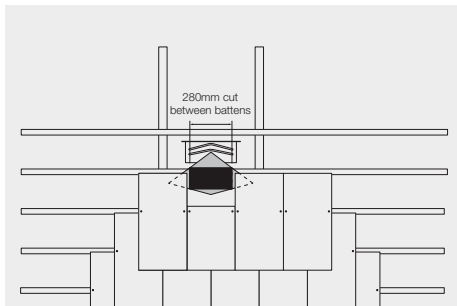

Fig. 12 – Determine position of ventilator

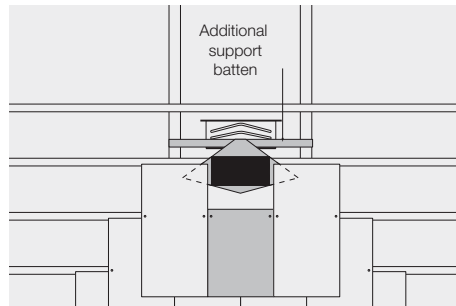

Fig. 13 – Secure additional support batten

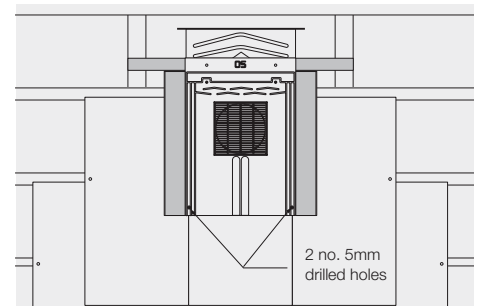
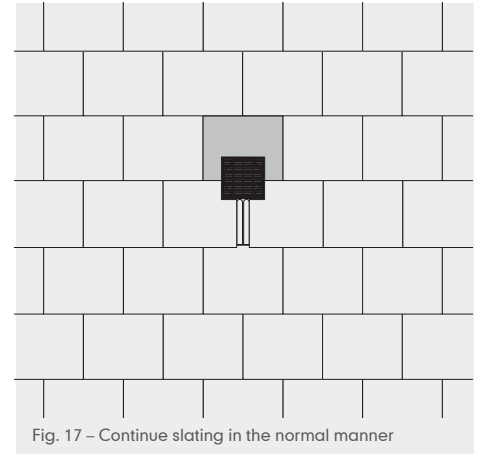
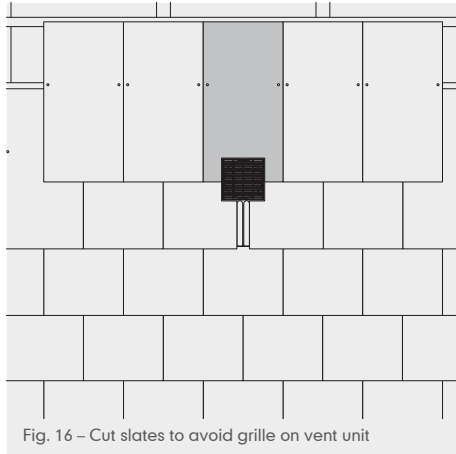
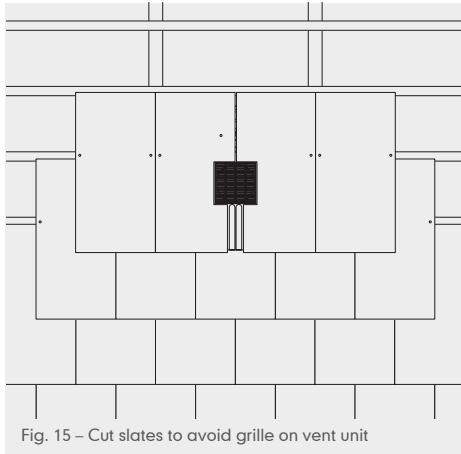

Fig. 14 – Secure underlay support to support batten

IN-LINE SLATE VENTILATOR

- 5 Cut two 'C' shaped slates to fit both sides of the ventilator so that they neatly abut the grille and central draining upstand.

Hole each formed slate piece as shown, ensuring that it is twice nailed to battens (Fig. 15). Continue slating in the normal manner.
- 6 Lay the next course of slates, cutting the slate directly above, to neatly abut the ventilator grille, as required. Inspect the junction security of the ventilating unit and adjacent slating before laying further courses. (Figs. 16 and 17). Continue slating in the normal manner.



BONDING GUTTERS

Mortar-free, BS 5534 compliant weathertight joins between dissimilar roof coverings. Dry Fix Bonding Gutters are manufactured from GRP. The Dry Fix Bonding Gutter eliminates the requirement for mortar altogether.

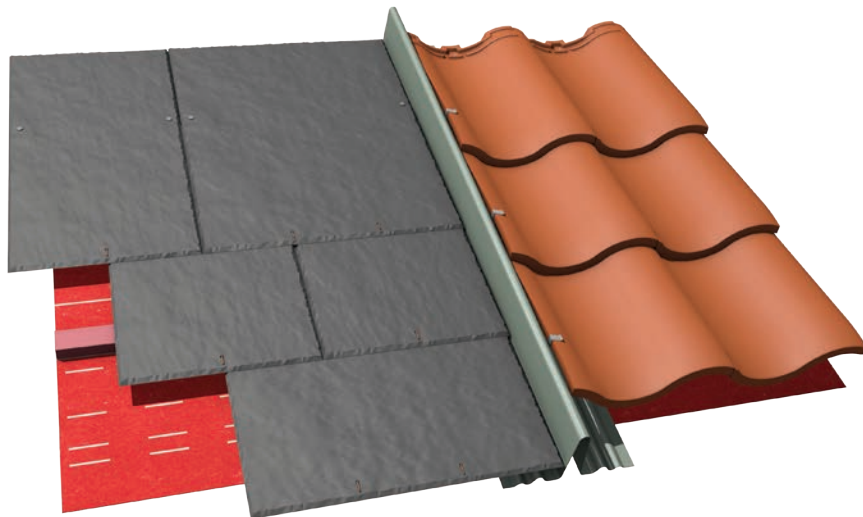

COMPONENTS

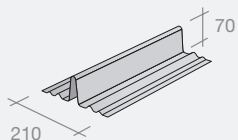

Low profile bonding gutter
(code 40470)

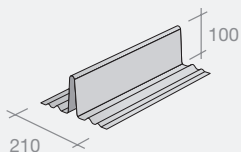

High profile bonding gutter
(code 40471)

BONDING GUTTERS

PREPARATION

The Dry Fix Bonding Gutter is designed to fix directly over the tiling or slating battens of both new and adjacent roof or over the underlay and directly into the sarking boards in a fully boarded roof, typical of Scottish practice.

Any battens and underlay on the adjacent roof should be checked for condition and if necessary renewed back to the nearest appropriate rafter, any defective nails should be replaced.

POSITIONING

The Dry Fix Bonding Gutter should be placed to allow the slate or tile bond to be maintained and using either a replacement tile-and-a-half or wider slate, as required.

Where the tile nibs may interfere with the bonding gutter profile, they should be removed and each tile mechanically fixed. Where standard fixings cannot be used, use either 'C' clips or secret cut tile clips (available separately).

INSTALLATION (FIGS. 1, 2 AND 3)

- 1 Before installing the Dry Fix Bonding Gutter, mark the centre line of its intended position onto the roof and then remove the slates or tiles for cutting.
- 2 With the slates or tiles removed, install the bonding gutter to the established centre line between the old and new roof, commencing at the eaves.

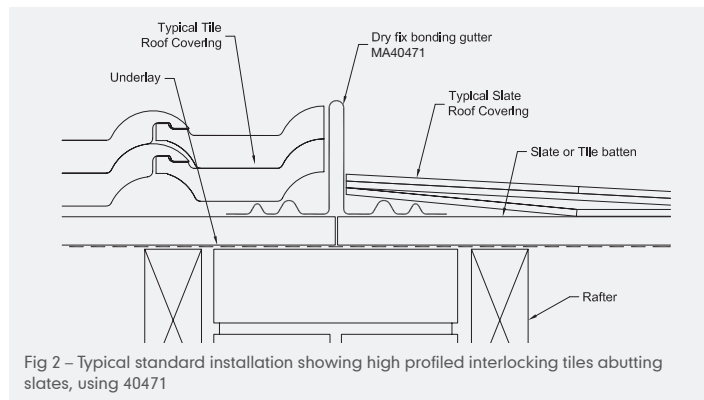
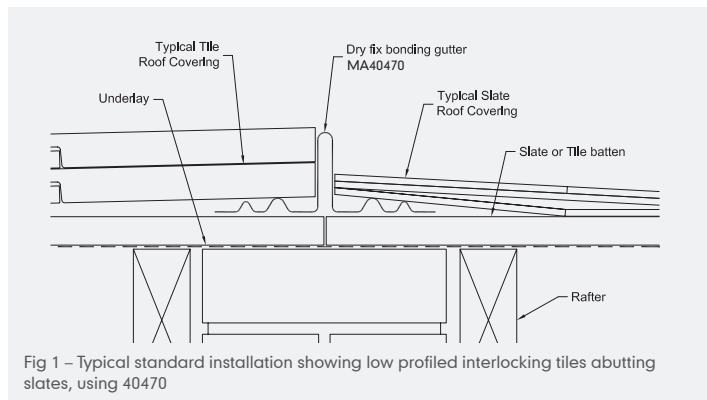

BONDING GUTTERS

- 3 Allowing for a 50mm overhang of the Dry Fix Bonding Gutter into the rainwater gutter, the central upstand should be pinched together before fixing with nails of acceptable quality through the outer flanges and into the battens on both sides and at 500mm centres maximum.

On roofs where there is a kick at the eaves, it may be necessary to install a lead saddle below the base of the Bonding Gutter.

- 4 When joining lengths of Dry Fix Bonding Gutter use the minimum lengths of overlap as follows:

Roof pitch	>39°	30-39°	22.5-29°	<22.5°
Overlap	150mm	200mm	300mm	350mm

- 5 The slates or tiles, when fitted onto the Dry Fix Bonding Gutter, should be close or touching the central upstand on both sides but with care taken to avoid any pressure or distortion and maintain the straight line appearance of the profile.

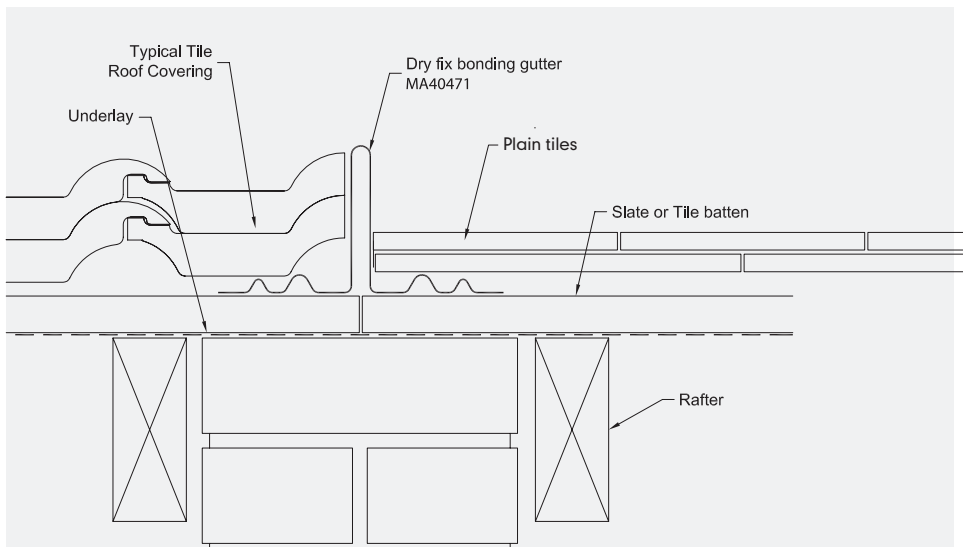

Fig. 3 – Typical standard installation showing high profiled interlocking tiles abutting slates, using 40471

- 6 When nailing the slates or tiles, care should be taken to avoid nailing into or between the water channels, this can be achieved by using wide slates/tiles where available or by bonding small cut tiles to the next full tile.

Note that all roof tiles adjacent to the bonding gutter must be twice mechanically fixed with either nails, tile clips, verge clips or a suitable adhesive

BONDING GUTTERS

- 7 At the ridge, consideration should be given to fitting a minimum code 4 lead saddle over the apex of the roof and dressed over the Dry Fix Bonding Gutter. The length of overlap of the saddle onto the Dry Fix Bonding Gutter should be in accordance with the overlap lengths given previously. Ridge tiles, whether dry fixed or mortar bedded, are fitted in the normal manner.

FIRE BREAK INSTALLATIONS (FIG. 4)

- 1 When creating a fire-break installation, e.g., at a party wall, the construction should be in accordance with the Building Regulations to provide a minimum of 30 minutes of protection from fire spread.

Firestop material should be laid beneath and above the underlay to fill all voids. It is important to ensure the separating walls stop approximately 25mm below the line of the rafters to prevent 'hogging'. Proprietary intumescent strips may also be used to create the firebreak.

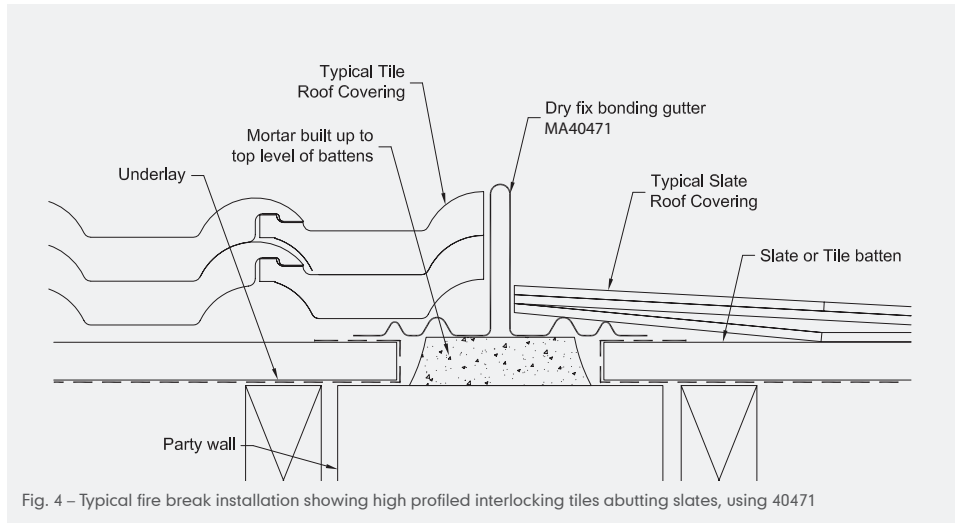

Fig. 4 – Typical fire break installation showing high profiled interlocking tiles abutting slates, using 40471

Alternatively, on existing firebreaks, the void below the bonding gutter can be filled with mortar. In this case, the underlay and battens should be set back as shown to leave a clear gap of no less than 50mm.



TABLES AND TERMINOLOGY

- 249 Eaves fascia heights
- 250 Ventilation roof tiles and vent terminal spacing
- 251 Open valleys – finished channel widths
- 252 Pitched roofing terminology
- 257 Resources

EAVES FASCIA HEIGHTS

The following tables, calculated using a 19mm thick timber fascia board with tile projecting 50mm beyond the front plane of the fascia. Heights shown will be affected where rigid sarking and counter battens (Scottish practice) are used or where there is variation in batten thickness, tile overhang, fascia thickness or pitch.

The eaves course of tiles must be in the same plane as the remainder of roof.

- 1 For comprehensive tabulated reference for vertical measurement of eaves fascia above rafter, see opposite. For measurements using the Marley Universal 10mm and 25mm Eaves ventilation systems, please refer to tables on page 136.

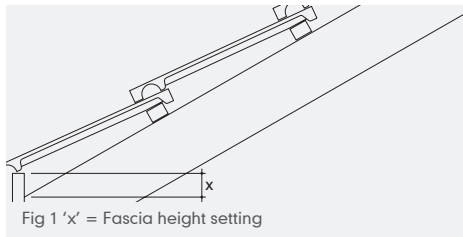

Fig 1 'x' = Fascia height setting

FASCIA HEIGHT SETTINGS (MM) 'X' WITHOUT OVER FASCIA VENTILATION SYSTEM*

Pitch	12.5°	15°	20°	30°	40°	50°	60°	70°
Anglia	–	–	–	34	34	38	72	95
Ashmore	–	–	–	44	44.6	50	–	–
Double Roman	–	–	31	32	34	38	49	–
Edgemere range	–	–	40	40	41	44	52	68
Lincoln	–	–	44	44	44	46	50	64
Ludlow Major	–	–	–	35	36	39	45	58
Ludlow Plus	–	–	–	33	35	55	65	84
Mendip	–	–	–	33	33	36	42	53
Modern/Duo Modern	–	–	47	48	51	58	71	98
Plain	–	–	–	–	45	50	58	76
Wessex	–	44	47	52	57	62	71	–

* The nominal dimensions given are for guidance only and may need to be adjusted to suit site requirements by ensuring that the eaves course of tiles or slates is supported in the same plane as the tiles on the main body of the roof.

VENTILATION ROOF TILES AND VENT TERMINAL SPACING

Product and profile	Code	Free area	Tile spacing to suit vent equivalent to gap of			Cover width
			5mm	10mm	25mm	
VENTILATION ROOF TILE						
Ashmore	263	4200mm ²	800mm	400mm	–	302mm
UNIVERSAL TILE VENT TERMINAL						
All profiles	36700	15000mm ²	3000mm	1200mm	600mm	–
IN-LINE VENT TERMINALS						
Clay plain tiles	–	6100mm ²	1220mm	610mm	245mm	330mm
Fibre cement slates	–	10,000mm ²	2000mm	1000mm	400mm	300mm
TILE VENT TERMINALS						
Double Roman	298	7614mm ²	1520mm	760mm	–	300mm
Edgemere range	259	7081mm ²	1415mm	705mm	–	290mm
Lincoln	123990/1	5000mm ²	500mm	500mm	–	224mm
Ludlow Major	297	7665mm ²	1530mm	765mm	–	295mm
Mendip	294	7107mm ²	1420mm	710mm	–	298mm
Modern / Duo Modern	295	7081mm ²	1415mm	705mm	–	292mm
Wessex	296	6929mm ²	1385mm	690mm	–	298mm

Product and profile	Code	Free area	Tile spacing to suit vent equivalent to gap of			Cover width
			5mm	10mm	25mm	
CONTOUR VENT TERMINALS						
Anglia (2 tile)	460	15000mm ²	3000mm	1500mm	600mm	408mm
Double Roman	453	13500mm ²	2700mm	1350mm	540mm	300mm
Edgemere range	465	10000mm ²	2000mm	1000mm	400mm	290mm
Ludlow Plus (2 tile)	457	15000mm ²	3000mm	1500mm	600mm	408mm
Ludlow Major	456	11000mm ²	2200mm	1100mm	440mm	295mm
Mendip	452	14500mm ²	2900mm	1450mm	580mm	298mm
Modern/Duo Modern	451	10000mm ²	2000mm	1000mm	400mm	292mm
Plain	455	10000mm ²	2000mm	1000mm	400mm	165mm
Wessex	459	12500mm ²	2500mm	1250mm	500mm	298mm
RIDGE VENT TERMINALS						
Concrete segmental	198	9500mm ²	1900mm	–	–	497mm

OPEN VALLEYS – FINISHED CHANNEL WIDTHS

MINIMUM WIDTHS OF VALLEY GUTTER FOR DIFFERENT ROOF PITCHES AND PLAN AREAS

Roof pitch	Design rainfall rate 225mm/h		Design rainfall rate 150mm/h		Design rainfall rate 75mm/h	
Degrees (°)	25m ² and less on plan (mm)	over 25m ² up to 100m ² on plan (mm)	25m ² and less on plan (mm)	over 25m ² up to 100m ² on plan (mm)	25m ² and less on plan (mm)	over 25m ² up to 100m ² on plan (mm)
15° - 17°	150	250	125	200	125	150
17.5° - 22°	125	200	125	150	100	125
22.5° - 29.5°	100	150	100	125	100	100
30° - 34.5°	100	125	100	100	100	100
> 35°	100	100	100	100	100	100

PITCHED ROOFING TERMINOLOGY

ABUTMENT – The junction of a roof surface with a wall, or any other structural feature which arises above it.

APEX– The highest point of the roof where the two slopes meet.

ARRIS HIP – A hip tile ordered specifically to suit the roof pitch.

BARGE BOARD – A board fixed along the edge of a gable.

BATTENS – Horizontal, small-section strips of timber graded to BS5534 on which tiles or slates are laid.

BATTEN GAUGE– Often referred to as ‘the gauge’. This is the measurement determined by the tile for batten spacing. It is the distance from the top of one batten to the top of the next batten below. Correct batten spacing is essential for a weather tight roof.

BATTEN VOID – The area above the underlay and below the roof covering.

BLOCK END RIDGE – A special ridge tile for use at the gable end. Often used with cloaked verge tiles.

BONDING GUTTER – A pre-formed length of flashing designed to weather the joint between two roofs with different types of roof coverings

BONNET HIP – Rounded hip tile used in plain tiling.

BROKEN/HALF BOND – A way of laying tiles so that the edge of each tile is above the middle of the tile in the course below. ($\frac{1}{4}$ and $\frac{3}{4}$ bond for mock joint tiles)

CLOAK VERGE TILE – A special tile fitting with a section which turns down at the verge

CLIP – Aluminium, steel or plastic device to secure tile to the roof structure beneath.

COLD ROOF – A roof designed with the insulation at ceiling level.

COUNTER BATTENS – Timbers fixed vertically between the battens and the surface below. A batten mounted vertically up the roof along the lines of the rafters. These are normally used where the roof frame has been boarded to give a space when the underfelt and battens are fixed.

COURSE – A horizontal row of tiles or slates.

CONDENSATION – Where hot air meets cold air, condensation is formed. For example, where heat rising from the inside of the house meets the cold underside of the roof covering, condensation occurs.

DECORATIVE RIDGE – A ridge tile available in a variety of shaped crests.

DENTIL SLIP – Small rectangular pieces of plain tile bedded into the pans of deep profile tiles to reduce the amount of mortar required for bedding hip and ridge tiles.

DOUBLE LAP – Description for roofing materials without interlocking channels (see single-lap).

DOUBLE PANTILE – Single-lap tile moulded to two pans in section.

DOUBLE CAMBER – A tile arched both horizontally and vertically to break up the dominance of the course line and give the roof an undulating look.

DRY RIDGE – A roof ridge which is mechanically fixed without mortar.

DRY VERGE – A roof verge which is mechanically fixed without mortar.

DRY VALLEY – A pre-formed valley liner which is mechanically fixed without mortar.

DRY HIP – A system which allows for a hip to be mechanically fixed without mortar

EAVES – The lower/draining edge of a roof.

EAVES/TOPS TILE – Shorter tiles used with plain tiles in a single course under the standard tile to give a double course of tiling at the eaves. A single course of short tiles is also used both sides of the ridge.

PITCHED ROOFING TERMINOLOGY

EAVES FILLER – A component that fills the space under the roll of a roof tile at the eaves to keep out birds, vermin and insects.

EFFLORESCENCE – The formation of a white crystalline deposit on the surface of a tile, caused by mineral migration to the surface.

FASCIA BOARD – The board attached vertically to the rafter ends at the eaves, the wall plate or the wall face.

FELT/MEMBRANE – (Also known as underlay or sarking felt). A water-resistant barrier, supplied in rolls and laid over rafters or counter battens.

FINIAL – A decorative fitting used at the end of a ridge or at the highest point of a roof.

FIXED GAUGE TILES – Tiles where the head lap is either fixed by mitred corners, or restricted by anti-capillary bars at the head and tail, often requiring a cut short-course at the ridge

FLASHING – A sheet of metal, usually lead or aluminium, which protects a joint from water penetration.

GABLE – The vertical triangular section of wall above the level of the eaves and below the sides of a pitched roof.

GABLE END – The end wall where two verges meet.

GAUGE – The distance between the top of one batten and the top of the next, equal to the length of tile exposed after it has been installed.

GUTTER (BACK) – A gutter formed at the back of a chimney, or any other structure which penetrates the roof.

GUTTER (SECRET) – A gutter formed at an abutment and effectively hidden from sight. (As opposed to Side Gutter, which is exposed to view).

GUTTER (VALLEY) – A visible gutter running down the valley.

GRANULAR/SANDFACED – A surface application of sand or small chippings.

HANDMADE – A plain tile made by hand for additional aesthetic requirements.

HANGING TILES – A general term which is applied to tiles fixed to vertical walls.

HANGING LENGTH – The distance measured from the underside of the hanging nibs to the bottom edge of a tile, used to aid setting out at the eaves to maintain correct overhang distance in relation to the gutters.

HALF BOND – Also known as broken or cross bond. Describes the laying pattern where the tile/slates are laid half way across the course below (all double lap materials).

HEAD-LAP – The measurement of the overlap of one course of slates or tiles over the course below (used to work out the batten gauge). Usually expressed as a maximum or minimum measurement in millimetres, defined by the tile or slate manufacturer.

HIP – The meeting of two pitched roof surfaces which meet at an external angle.

HIP BOARD – The board along the line of a hip, from the fascia to the ridge of the pitch.

HIP IRON – A metal strap bent to form a stop for the hip covering and screwed to the lower end of a hip rafter.

HIP TILE – A fitting designed to cover the hip intersection of a pitched roof of a given pitch.

HIP END – A sloping end to a pitched roof which is covered with slates or tiles.

HIP END RIDGE – A ridge tile that is used at the end of the ridge, where it meets 2 hips. Suitable for use with plain tiles with bonnet, arris or mitred hips, also suitable for use with slates with mitred hips.

HYBRID ROOF – A combination of cold and warm roof on the same roof slope.

PITCHED ROOFING TERMINOLOGY

INTERLOCKING TILE – A single-lap tile designed to connect with adjoining tiles by close fitting weather bars/rain channels.

LAP – The amount by which a tile overlaps the course below it - or, in the case of plain tiles, the course next but one.

LEAN-TO ROOF – A single pitched roof slope, which meets with a wall abutment along the top edge.

LEAD SLATE – Provides weather-tight joints where flue pipes and soil stacks penetrate a roof covering.

LEAD REPLACEMENT FLASHINGS – Proprietary flashings designed to replace lead

MITRE – Materials cut so they form a close fit.

MANSARD ROOF – A roof having two slopes on both sides and ends, the lower slopes being steeper in pitch.

MARGIN – The length of tile visible once laid (equal to the batten gauge).

MOCK JOINT – Artificial line that gives small format appearance to a tile.

MONOPITCH ROOF – A pitched roof with a single slope from eaves to ridge.

NIBS – Projecting lugs on the underside of a tile near the head, which locate the tile on the battens.

NATURAL WEATHERING – The process of external building materials changing in appearance according to their environment.

OVERHANG – Distance that the undercloak extends over the verge or the distance by which tiles extend over the fascia board into the gutter.

OVER FASCIA VENT – provides discrete low level ventilation.

PANTILE – Single-lap tile moulded to a flat S-shape in section.

PITCH – The angle of the roof to the horizontal. (Normally applies to the rafters).

PLAIN TILE – A small, slightly cambered roofing tile, typically size 267mm x 165mm. Usually with nibs and nail holes.

PEG TILE – A tile similar to a plain tile but without nibs and with holes for pegs.

POINTING/BEDDING – The use of mortar or cement to fill the gap between the tile and the under cloak at the verges.

PURLIN – A horizontal length of timber that provides support to rafters.

RAFTER – A vertical, sloping timber used to form the shape of the roof - the side of a truss.

RAKING CUT – A diagonal cut across courses or rows of tiles.

RECONSTITUTED SLATE – A modern, manufactured product which consists of crushed natural slate which is bound together using resins.

RIDGE APEX – The junction of two slopes forming the apex of a pitched roof.

RIDGE TILE – A fitting designed to cover the apex of a pitched roof of a given pitch.

RIDGE VENT TERMINAL – A ridge tile which incorporates a ventilation outlet.

ROOF JUNCTION – Is the detail where two or more roof slopes meet, for example, a ridge line, a hip or a valley.

SADDLE – A piece of impervious flexible sheet material (usually lead) dressed to shape, fitted to provide weather protection.

SARKING FELT – Another name for roofing underfelt/underlay

SARKING BOARD – Sarking is wood boarding used under tiles or slates to provide support to the underlay, commonly used in Scotland.

PITCHED ROOFING TERMINOLOGY

SETTING OUT – Ensuring a consistent appearance of the courses, considering the required headlap and dimensions of the roof (see chapter x)

SIDE-LAP – The distance which one tile/slate is off-set from the edge of the one below (see also half bond).

SINGLE-CAMBER – A traditional plain tile, arched along its length from head to tail providing a neat, clean aspect with emphasis on the course line of each row of tiles.

SINGLE-LAP – Description for roofing materials such as concrete interlocking tiles and fixed gauge clay tiles that rely upon an interlock at the sides of the tile to provide waterproofing (see also double-lap).

SINGLE LAPPED TILES – Tiles that have side interlocks and drainage channels to drain away the water.

SOAKER – A small piece of sheet (usually lead), shaped and inserted between double lap tiles or slates on the abutment between a roof slope and a vertical wall, or at a mitred hip or valley.

SOAKER (DRY) – A preformed component inserted between tiles or slates on the abutment between a roof slope and a vertical wall.

SOFFIT BOARD – Board fixed to the feet of rafters

which forms the underside of projecting eaves.

SOLDIER COURSE – A decorative gable-end finish normally done using plain tiles

SPAN – The distance between the walls which support the roof.

SPROCKET – An alteration in pitch from steep to shallow, normally close to the eaves (Bellcast).

STANDARDS – The British Standards are a guide to how materials should be fitted and fixed.

SUSSEX CUT – A decorative gable-end finish normally done using plain tiles and tile-and-a-halves

TILE-AND-A HALF (gable tile) – A tile one and a half times the width of a standard plain tile to maintain a broken bond at verges and abutments. Sometimes called a gable tile.

TILTING FILLET – A tapered section of timber fitted to the eaves to support the first course of tiles or slates and prevent a trough in the underlay

TRUSS – A factory made roof frame.

UNDERCLOAK – Roofing slates, plain tiles or fibre cement strip fixed at the verge beneath the battens, on to which the verge tiles are bedded.

UNDER EAVES COURSE – A row of shorter plain tiles or slates laid broken/half bond under the first full course to maintain the required head and side laps.

UNDERLAY – A breathable or non-breathable membrane acting as a barrier between the roof covering and the substructure (see also Felt).

UNDERLAY SUPPORT TRAYS – A preformed tray used to support the underlay at the eaves to prevent troughs and water traps.

VARIABLE GAUGE TILES – Tiles where the batten gauge can be easily adjusted (i.e., reduced) to fit the rafter length

VALLEY – The junction of two inclined roof surfaces at an internal angle.

VALLEY TILE – A concrete or clay tile used at valleys with plain tiles.

VALLEY TROUGH – A concrete tile fitting used for weathering valley junctions when using interlocking tiles (now superseded by preformed valley liners)

VAPOUR CONTROL LAYER (VCL) – A non-permeable membrane fitted to the warm side of the insulation, intended to restrict the transmission of water vapour.

PITCHED ROOFING TERMINOLOGY

VENT TERMINAL – A roof tile fitted with a hood and grille for natural ventilation which can also be connected to soil pipes or mechanical extractors.

VENTILATION TILE – to ventilate the roof space or for soil vent pipe (SVP) / mechanical extraction

Cowl Ventilators – A cowl tile ventilator has a cowl or cap on the top of the ventilator (sticks out above the roof line).

Concealed Ventilators – A concealed tile ventilator has an in-built grille which is inset into the ventilator (does not stick out above the roof line).

VERGE – A free end of a roof surface; for example, that at the end of a gable or dormer.

VERGE TILE – A special tile to allow courses to be laid 'broken bonded' or Special tiles designed to neatly finish off the left hand side of the tiling so it is in keeping with the rest of the roof (i.e. double roll pan tiles).

VERTICAL TILING – Sometimes known as 'tile hanging', where roofing battens are fixed to a vertical surface such as a wall or dormer cheek. Plain tiles are then fixed to the battens.

WALL PLATE – Length of timber which is fixed to the top of a wall to secure the rafters.

WARM ROOF – A roof designed with the insulation at rafter level

WINCHESTER CUT – A decorative gable-end finish normally done using plain tiles and tile-and-a-halfs



Here to help

Getting our knowledge to you and your project smoothly and efficiently

▲ CUSTOMER SERVICES

Knowledgeable and friendly staff are available to offer quotations, expert advice, deal with orders and all other enquiries. Call 01283 722588 or e-mail customerservices@marley.co.uk

▲ TECHNICAL ADVICE

Our Technical Advisory Service is staffed by a qualified team with specialist knowledge. Call 01283 722588 or e-mail roofing@marley.co.uk

▲ TOOLS

ROOF SYSTEM SELECTOR

Easy-to-use and comprehensive system finder delivering results from choice of pitch, material or tile type: marley.co.uk/productselector

SOLAR CONFIGURATOR

Making pricing jobs and calculating panel performance simple: marley.co.uk/technical-services/solar-configurator

SPECIFICATION TOOLS

Specrite, Estimator and Tilefix give the specifier and installer all the specification and installation help they need: marley.co.uk/specrite
marley.co.uk/estimator
marley.co.uk/tilefix

BIM

BIM Space is a set of free-to-download Building Information Modelling (BIM) objects that provide a standard range of build ups for all of our products: marley.co.uk/bim

CAD

Access to over 2,000 CAD drawings illustrating how specific tile and slate details can be formed: marley.co.uk/cad

▲ RESOURCES AND TRAINING

SAMPLES

Samples of clay and concrete interlocking and plain tiles, and Shingles or Shakes are available on request. Call 01283 722588 or visit marley.co.uk/samples

FIXING INSTRUCTIONS AND LITERATURE

Comprehensive sitework, fixing and installation literature and videos: marley.co.uk/resources
All current product and technical literature can be downloaded: marley.co.uk/downloads

CPDS

A range of Continuous Professional Development roofing seminars accredited by the RIBA CPD Certification Service. For more information or to make a booking: marley.co.uk/cpd

TRAINING

Theoretical, practical, engaging and informative training available at our Burton-on-Trent site: marley.co.uk/training

V1.0 - 01.07.2024
- New brochure version 1

V1.1 - 16.10.2024
- (p239) free area ventilation changed from 7500 to 6100mm²
- (p250) free ventilation area and vent spacings updated in line with above changes



Tell me more

Call 01283 722588

Email info@marley.co.uk

Or visit marley.co.uk

Marley, Lichfield Road,
Branston,
Burton upon Trent,
DE14 3HD

V1.1 - 16.10.2024

