

Warranty, Support and End of Life Disposal

Warranty

The Timed Urinal Control System is guaranteed for 5 years from purchase against defective material and assembly.

The solenoid valve is guaranteed for 12 months, subject to water condition, however it is expected that the valve internals will operate efficiently for many years.

Support

For technical support please visit our technical pages on our website at www.dartvalley.co.uk or contact us by e-mail at techsupport@dartvalley.co.uk. Alternatively, you can telephone us direct on 01803 529021 and our customer service team will be pleased to help you.

Disposal of electrical and electronic equipment



The use of this crossed out wheeled bin logo indicates that this product needs to be disposed of separately to any other household waste.

Within each of the European Union member countries, provisions have been made for the collection and recycling of unwanted electrical and electronic equipment. Outside of the EU it will be necessary to dispose of this product at your local community waste collection or recycling centre. In order to help preserve our environment we ask that you dispose of this product correctly. Please contact your local council for collection centre details.

Disposal of waste batteries



The use of this crossed out wheeled bin logo indicates that the battery needs to be disposed of separately to any other household waste.

Within each of the European Union member countries, provisions have been made for the collection and recycling of waste batteries. Outside of the EU it will be necessary to dispose of this product at your local community waste collection or recycling centre.

In order to help preserve our environment we ask that you dispose of this battery correctly. Please contact your local council for collection centre details.

Head Office

Dart Valley Systems Ltd
Kemings Close
Long Road
Paignton
Devon
UK
TQ4 7TW

Contact Details

t : +44 (0) 1803 529021
f : +44 (0) 1803 559016
e : techsupport@dartvalley.co.uk
w : www.dartvalley.co.uk

TIMED URINAL CONTROL

Battery (UC01-010)

Mains (UC01-011)

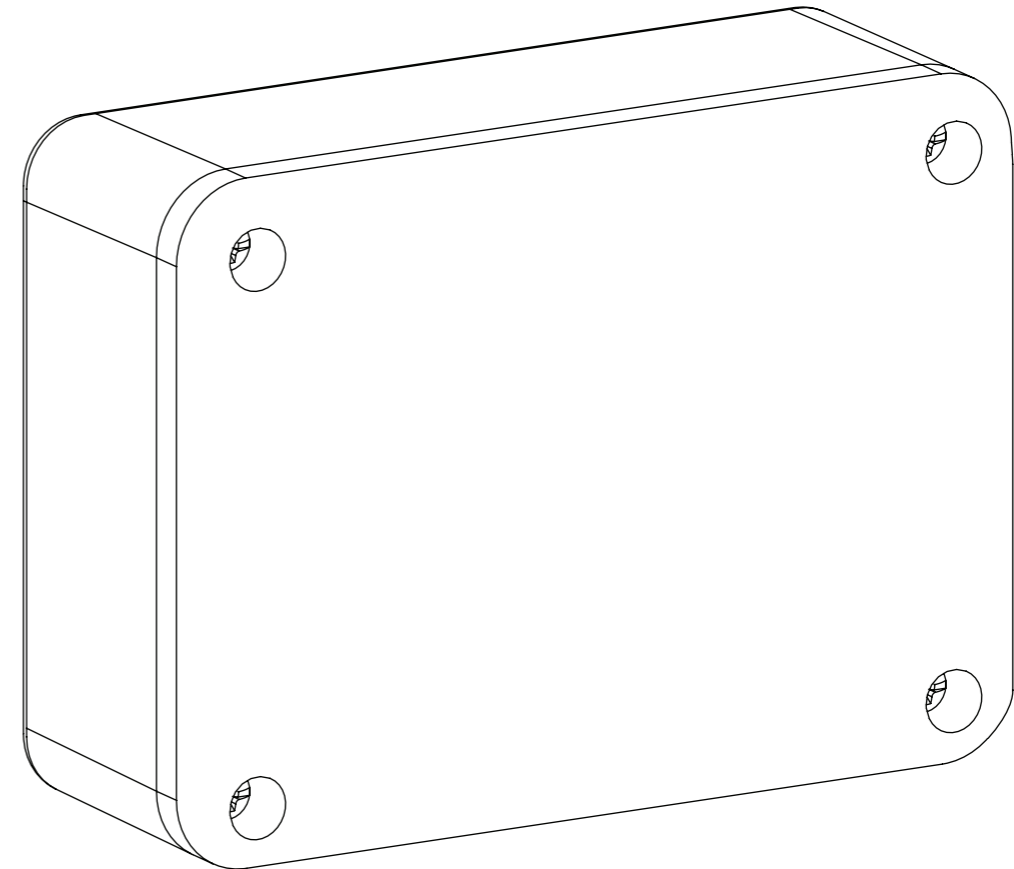

Step 8 : Test Mode

With all the switches of the 4 way switch in the 'off' position, the unit is set to test mode. After power up/reset the valve will open for 5 seconds and will remain open for a period set by 6 way dip switches, or if all switches are in the off position, then it will be the default 5 seconds. This cycle will then repeat after 5 seconds and continue to do so whilst still in test mode. To exit test mode a time must be set and the reset button pressed. The solenoid valve will close.

If nothing happens check all connections, reset board and try again.

Step 9 : Fault Finding

1. VALVE WILL NOT OPEN OR CLOSE PROPERLY

- Check valve supplied is suitable for the on site pressure, if in doubt contact DVS for advice.
- The solenoid valve has a flow direction so ensure it is the right way round.
- There maybe debris in the solenoid valve. Remove valve and flush under running tap, refit and test.

2. CONTROL BOX WILL DO NOTHING

- If possible check voltage from battery or power supply unit, (6 volt DC required).
- Control board may have locked up. With power connected press reset and try again.
- Check fuse on control board. If blown check wiring and contact DVS for replacement.

3. VALVE OPENS AND RUNS FOR A LONG PERIOD BEFORE SHUTTING OFF.

- Check wiring to the plug on solenoid, it may be wired the wrong way round, reverse wires if necessary.
- Make sure all connections are correct and tight.

Step 1 : Safety First

These instructions relate to the use of the Timed Urinal Control System only, any external or 'add-on' parts will be supplied with separate instructions.

During installation, do not expose electronics to dust, dirt or damp. It is recommended that the electrical part of the installation be carried out by a qualified electrician in accordance with the latest electrical regulations. It is also recommended that any plumbing is carried out by a qualified plumber.

This is a sophisticated electronic device which must be installed correctly to perform correctly.

If the appliance is used by persons (including children) with reduced physical, sensory or mental capabilities, or lack of experience and knowledge, they must be given adequate supervision or instruction concerning use of the appliance by a person responsible for their safety.

Children should be supervised to ensure that they do not play with the appliance.



IMPORTANT: Please read these instructions carefully and follow each stage in order!

Step 2 : Kit Contents

A typical kit will include; Timed Urinal Control Box, one solenoid valve and a lithium 6-volt battery. Alternatively you may have a DVS power supply, which will need to be connected to a mains 240V output point.

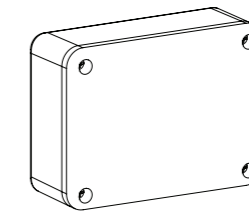

Control Box
Battery (UC01-010)
Mains (UC01-011)

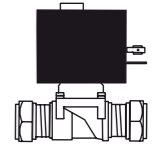

6V DC Solenoid valve
AC17-006

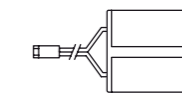

Battery pack 6V (for
battery version)
UC00-006

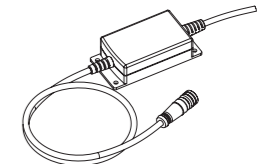

PSU (for mains
version)
UC00-016

*Not to scale

Step 3 : Plumbing

Fitting the Solenoid Valve

Turn off the local water supply and locate the solenoid valve in a position, as near to the cistern as possible and preferably upright (shown below). Cut the supply pipe and purge any debris or swarf. Fit Solenoid valve ensuring joints are tightened and checked for leaks. In the event of very low or high water pressure the manufacturer can offer alternative solenoid valves under special request.

It is highly recommended that a water filter (not supplied) be fitted prior to the solenoid valve to ensure reliable operation.

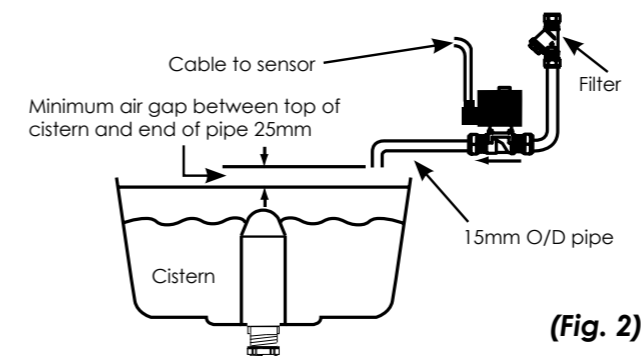

(Fig. 2)

Step 4 : Mounting the Control Box

Positioning the Control Box

The control box is rated IPX0 and should be located in a dry location, away from extremes of temperature and not exposed to dirt dust or damp. The unit should be accessible when required but not within easy reach of unauthorised persons.

Standard Surface Mount Model

Remove the lid/cover and place in a safe place. Select a convenient cable entry point on the box, then drill and fit an appropriate cable gland.

Drill and secure the control box base to the required position on the ceiling with suitable fittings. Fit one end of the valve cable into the box base and tighten cable gland, temporarily refit the control box lid/cover.

(Fig. 3)

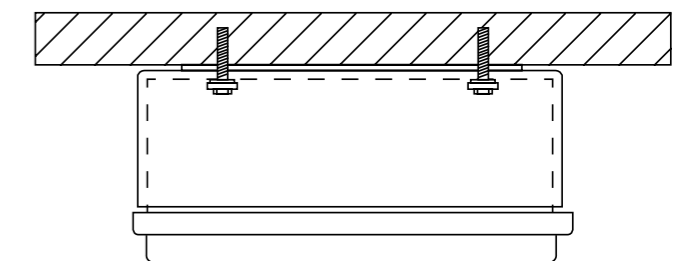

Step 5 : Wiring & Electrical

Power Input

The power supply required for the sensor is 6 volts DC which can either be supplied by a battery or a DVS mains Power Supply Unit (PSU).

Battery Version

The battery supplied has a simple 2 pin connector and great care must be taken to connect it in polarity (see Fig.4).

The battery is premounted into the unit using double sided tape. At the end of the battery life, the battery should be gently pulled off the surface of the unit and disposed of according to the disposal instructions at the end of these instructions. Replacement batteries can be purchased through your supplier or direct from DVS

Caution must be exercised with Lithium type batteries:

1. DO NOT attempt to recharge
2. DO NOT expose to naked flames
3. DO NOT 'short circuit' battery
4. DO dispose of battery with care

Mains Version

If a DVS power supply unit is used, the battery is not required and the output cable from the power supply is simply connected instead of the battery (see Fig.4).

Ensure the cable is housed safely within the sensor enclosure with a cable gland.

A 1m length of 0.75mm 2 core flex is supplied with the PSU - this must not be extended.

The PSU should be located in a dry location, away from extremes of temperature and not exposed to dirt, dust or damp

Always connect the power via a 3 amp fused spur. The product must be permanently connected to the supply, fitting a plug is prohibited. A suitable means of disconnection should be provided, in accordance with local electrical regulations. If the mains lead becomes damaged, the product should not be used. Contact DVS for replacement parts.

Valve Input

Fig. 5 shows the connection of the valve cable to the sensors PCB. The wire should be round 2 core 0.5mm diameter, trim the valve cable to length you require and prepare ends (see Fig. 5) but do not connect to sensor at this stage.

Wiring must comply with Local and National regulations. Connection to the coil must be made via the supplied spade plug connector. The coil can be rotated through 360° to facilitate wiring.

(Fig. 4)

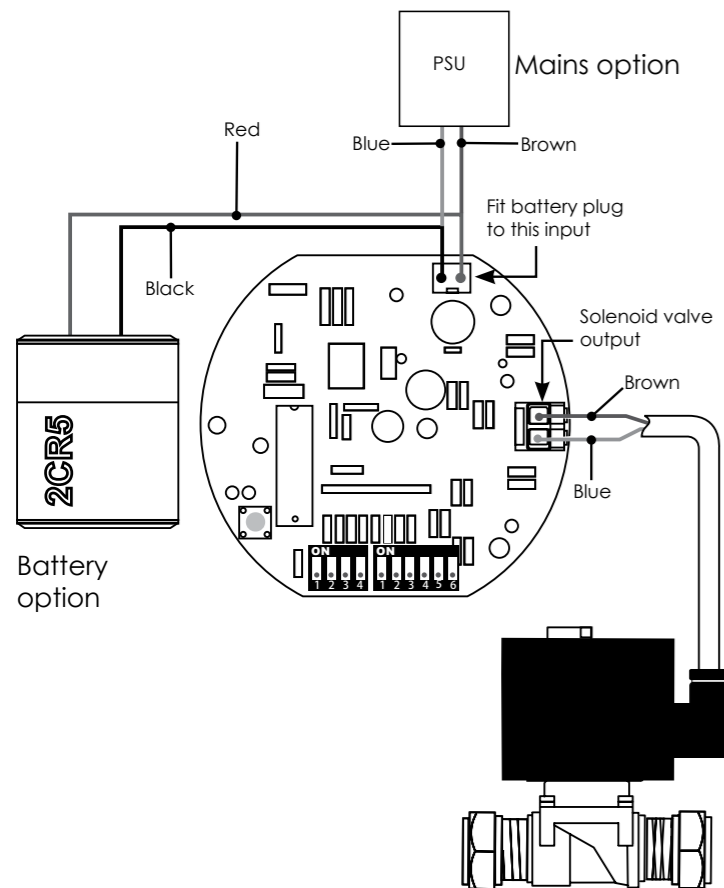

(Fig. 5)

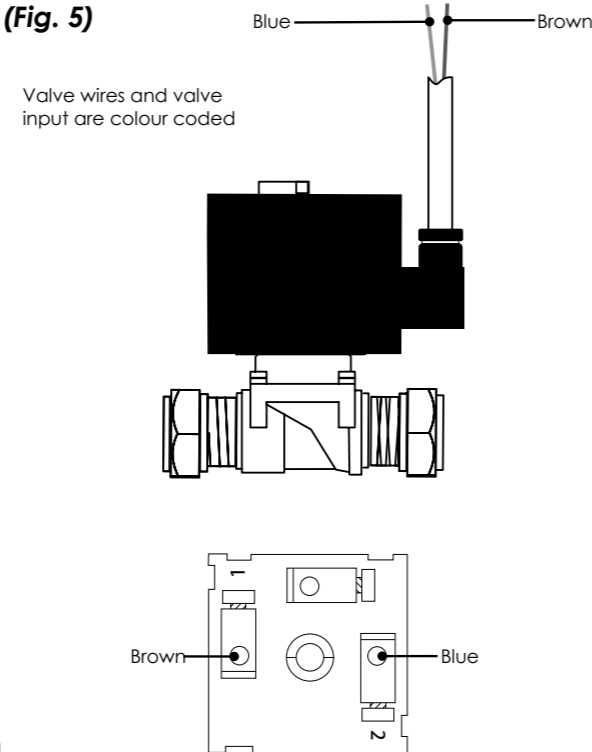

Note: Always press the RESET button after reconnecting the power to the PCB.

Step 6 : Setup - Cistern Fill Time

There are two stages to the setup. First the cistern fill time needs to be determined and set.

Cistern Fill Time

Important! The cistern must be empty of water to set the fill time.

To do this, open the solenoid valve manually by momentarily touching the solenoid contacts directly onto the battery to 'pulse' the valve open (as shown below).

(A PP3 9-volt DC battery may be used to 'pulse' solenoid valve).

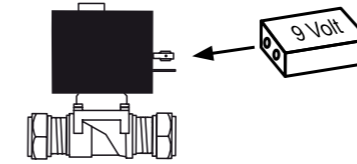

CAUTION! Manual opening/closing of solenoid valve is performed by briefly touching the valve wires onto a 6/9 Volt DC battery. Do not leave wires connected to battery as it may cause solenoid damage or personal injury.

If the valve does not open, reverse the polarity and repeat the process. When the cistern starts to flush, turn the solenoid valve off by reversing the 'pulse' procedure, and allow the cistern to completely discharge and empty. 'Pulse' the solenoid valve 'on', and with a stopwatch, time how long the cistern takes to fill and flush.

Next select and set the combination of switches required to equal the recorded fill time (as shown in Fig. 6 below). Finally connect the valve wires carefully to the PCB connector and fit to the PCB. (See Fig. 4 and 5)

Valve Open Control Switches

(Fig. 6)

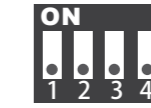

FLUSH DELAY TIME WITH SWITCH ON:

- 1 = 1 Hour
- 2 = 2 Hours
- 3 = 4 Hours
- 4 = 8 Hours



VALVE OPEN TIME (CISTERN FILL TIME) WITH SWITCH ON:

- 1 = 15 Seconds
- 2 = 30 Seconds
- 3 = 1 Minute
- 4 = 2 Minutes
- 5 = 4 Minutes
- 6 = 8 Minutes

The control box is supplied set in 'test mode' all switches in the off position.

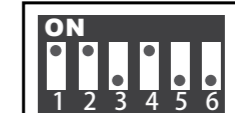

You may use any combination of these switches, as demonstrated left.

With reference to Fig 6:

Switches 1 + 2 + 4 on = 2 minutes and 45 seconds

Step 6 : Setup - Cistern Fill Time (Continued)

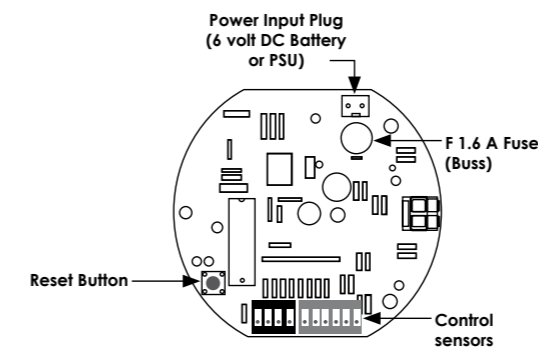

Please ensure correct polarity of the solenoid valve connection (see step 5 notes). Then re-connect the battery or 6-volt DC PSU power to the sensor PCB (see step 5 notes). Wait approximately 45 seconds for the PCB to charge. The valve will open for the time set by the 6 way switch.

Check the solenoid valve opens and enough water passes into the cistern, and check that a flush takes place before the solenoid valve closes.

Modify the cistern fill time switch settings if required (Fig 6).

There will then be an interval time set by the 4 way switch (section 7: Setup - Interval time).

If all the switches are set to 'off', the control box is set to test mode and the cycle will repeat after 5 seconds.

Step 7 : Setup - Interval Time

Interval Time

The interval time between flushes is set using the 4 way dip switch (Fig. 6)

The time between flushes can be set between 2 and 24 times a day. The set time includes the cistern fill time i.e. if the interval time is set to 1 hour and the fill time to 5 minutes, this valve will open after 55 minutes to initiate a flush after 1 hour.

The 4 way dip switch settings for various interval times are given in Fig. 7 below.

(Fig. 7)

Interval time	No.1 = 1 hour	No.2 = 2 hours	No.3 = 4 hours	No.4 = 8 hours
1 hour	on	-	-	-
2 hours	-	on	-	-
3 hours	on	on	-	-
4 hours	-	-	on	-
5 hours	on	-	on	-
6 hours	-	on	on	-
7 hours	on	on	on	-
8 hours	-	-	-	on
9 hours	on	-	-	on
10 hours	-	on	-	on
11 hours	on	on	-	on
12 hours	-	-	on	on

Fig. 7. 4 way dip switch setting for interval time.