



**Stannah
Midilift SL/GL
Platform lifts**

The Stannah Midilift platform lift range offers a simple, cost effective way to provide access for all within public, commercial or domestic buildings.

www.stannahlifts.co.uk

Stannah

Stannah Midilift platform lifts

Introduction



Fire rated wood finish door

Our latest Midilift combines design, versatility and intuitive use with ease of installation and reliable performance – with more finish choices to customise your lift to suit your building and more user-friendly features for the end user.

Midilift can be installed in new and existing buildings, complementing and blending into any environment, either internally or externally. Predominantly used as wheelchair or disabled lifts, these lifts require no pit, are installed in their own structure and can travel up to 7 metres. The half height gate option, for up to 3 metres of travel, is ideal for enabling access to mezzanine floors or where there are headroom restrictions.

Our platform lifts help building designers and owners to meet the requirements of Part M and BS 8300, as well as helping to meet obligations under EN81-41 and the Equality Act (formerly the DDA), whilst taking up the minimal amount of building space possible.

A UK manufacturer, Stannah have proudly provided more than 5,000 Midilift platform lifts. These lifts are installed throughout the UK, across all market sectors, including education, retail, offices, public buildings and private residences. Our proven hydraulic drive and energy-efficient lighting coupled with our nationwide service ensures our lifts run smoothly and efficiently for years, adding value to any building.



Midilift SL in residential setting



Stylish brushed aluminium console

Stannah Midilift platform lifts

Products

Products

There are two products in the Midilift range, both of which are suitable for indoor and outdoor use.

Midilift SL

The Midilift SL platform lift travels up to 7 metres providing a solution for higher travel and an increased number of stops. There is a wide range of design options for the structure and platform to ensure the lift matches your building requirements.

Midilift GL

The Midilift GL platform lift is a low-cost option for mezzanine floors. This lift travels up to 3 metres with a half height gate at the top. It can also be an ideal solution if headroom is restricted on the second floor.

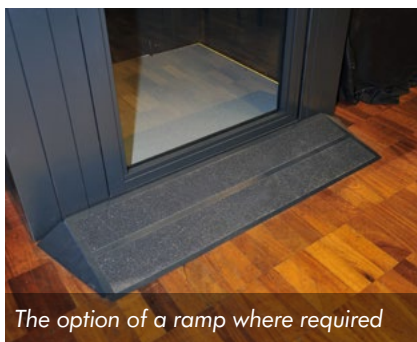

The option of a ramp where required



Internal view of structure



Full height door model (external option)



Mahogany brown Midilift GL

Stannah Midilift platform lifts

Key benefits

Key benefits

- Up to 7m travel with three platform sizes available to suit buildings of different shapes and sizes
- Compact shaft with a choice of entrance configurations
- Minimal builders work required and quick installation time
- Structure-supported enclosure – no lifting beam required
- Flexibility on drive control unit location
- Low pit requirements with ramp where a 70mm recess is not possible
- Low running and maintenance costs due to the single phase power consumption
- Choice of finishes or branding to complement any building design and to make your lift unique
- Helps building owners to conform with Part M and the Equality Act
- Finish and specification for outdoor and indoor use

The external option for the Midilift means you have a lift built for outdoors, with a specification to withstand extreme temperatures and a 5-year anti-corrosion warranty.

BREEAM

A Stannah Midilift falls under the Supply of Machinery (Safety) Regulations, which means it travels at no faster than 0.15m/s. By choosing this lift as opposed to a passenger lift, the BREEAM criteria does not apply and your overall BREEAM score is reduced as a result.

Installation & Warranty

Installation typically takes 1-4 days, depending on site conditions and lift travel.

All our lifts are supplied with a 12-month warranty with four service visits as standard and we offer a range of service options tailored to suit your specific requirements.

Stannah also offer cabin platform lifts – the Midilift Plus range

offering the feel of a passenger lift but with all the access benefits of a platform lift – ask for further details.



Stylish brushed aluminium console

DDU as standard

Mid panel providing visual contrast design

Larger, easy to use buttons

Buttons externally rated for outdoor option

Longer handrail

45° angle for easier operation

Stannah Midilift platform lifts

Features and options at a glance

Standard features:

Carriage:

Moving platform and console within lift structure

Large illuminated constant pressure call buttons – 50mm square

Audible and visual notification of floor level and travel direction

Voice annunciation with arrival chime

Alarm button

Emergency stop switch

Red digital display units with direction arrow and overload indicator

Battery backed up LED lighting

Handrail in satin stainless steel

Mechanical safety edges around platform

Landing features:

Complete lift isolation keyswitch (supplied on lower landing only)

Landing controls:

One-touch landing controls mounted on lift door frame

Other features:

Automatic emergency lowering feature

Two-way intercom communication system for emergency calls

Emergency lighting and alarm with back-up battery

Structure:

Structure supported enclosure with powder coated steel solid infill panels

LED ceiling spot lights with timer (SL only)

Doors:

Panoramic glass door fitted with door closer

800/900mm clear opening at each entrance

The Midilift helps to meet the requirements of:

- The Equality Act
- Part M of the Building Regulations (England and Wales) and Section 4.2 of the Technical Handbook (Scotland), both of which cover the requirements that many new buildings must meet to ensure ease of access and use
- BS 8300:2018 (Parts 1 & 2) Code of practice covering the design of an accessible and inclusive internal and external built environment

All of our Midilifts are UKCA marked and comply with the Supply of Machinery (Safety) Regulations 2008 (2008 No. 1597).

Options available:

Carriage:

Joystick – 2 floor lift only

Landing features:

Key operated locking control at each landing to restrict lift access

Blue digital display units with fixed direction arrow

Landing controls:

Flush wall mounted landing controls

Pedestal mounted landing controls

Other features:

Battery backup in both directions

Klaxon alarm fitted to structure

Emergency telephone (phone line supplied separately)

Memcom auto-dialler/auto-dialler with inductive loop

Fire alarm shutdown (to lowest floor only)

Welsh signage and instructions

Outdoor control cabinet

Structure:

Glass infill panels (clear or tinted)

Fixed ramp at the lower level

Special fixing brackets/hoops (if required)

Pre-drilled full enclosure/landings/sides (fire cladding)

Reduced headroom †

Door options:

30/60 min fire rated door – primed or wood finish (see finishes page)

Doors by others to match overall building style

Half height gate – GL

Automatic door opener/closer

Concealed door closer

External:

External specification built to cope with a range of weather

E-coat primer with an architectural powder coat

Door canopy

Roof fan for heat extraction (optional)

Oil heater as standard for cold weather

IP54 rated buttons 50mm square

† There are instances in which we can reduce the headroom – please contact us to discuss further.

Stannah Midilift platform lifts

Technical data

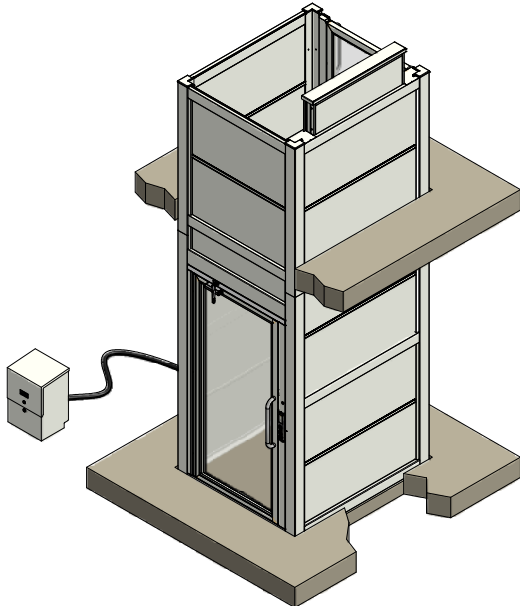

Midilift GL with half height upper gate

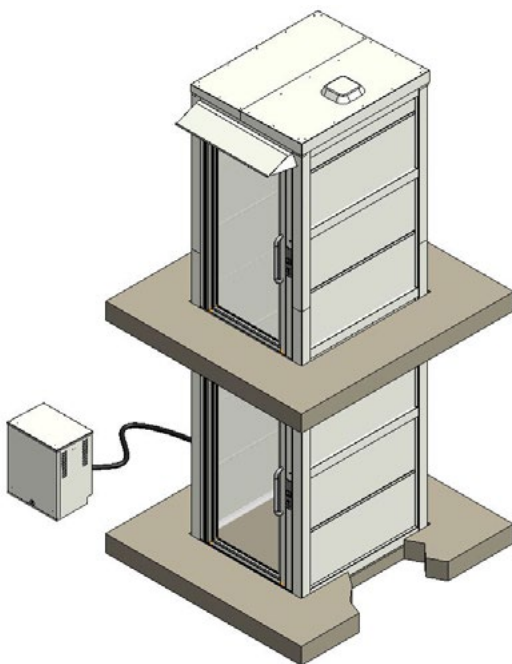

Midilift SL with roof and door canopy (external option shown)

Dimensions			
Platform size (w x d)	Aperture size (w x d)	Pit depth	Headroom
950 x 1250	1240 x 1440 [◇]	70*	Variable – please see notes [†]
950 x 1400 [#]	1240 x 1560 [◇]	70*	
1100 x 1400 ^{#‡}	1360 x 1560 [◇]	70*	

Technical specifications		
	Midilift GL ½ height gate	Midilift SL Full height door
Standard load	400kg	
Maximum travel	3m	7m
Speed of travel	Up to 0.15m/s	
Drive system	Hydraulic (includes separate pump)	
Platform control system	Constant pressure	
Power supply	240v single phase	

Notes:

All dimensions are in mm.

* A ramp can be used where this pit depth is not possible.

† Headroom is dependent upon the travel – please contact us for more information.

Part M (England and Wales) compliant (950 x 1400 for unattended wheelchair use and 1100 x 1400 for attended use).

‡ Section 4.2 (Scotland) compliant.

◇ Aperture dimensions will increase by 10mm on each side when a 60 minute fire door is specified.

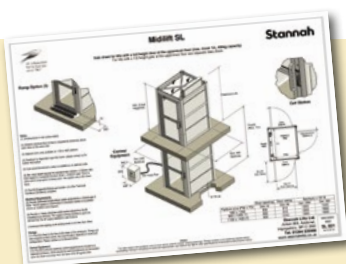







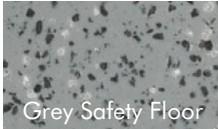

NBS Specifications, CAD blocks and data sheets giving further technical information are all available from our web site.

www.stannahlifts.co.uk/downloads

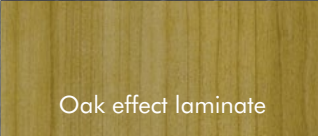
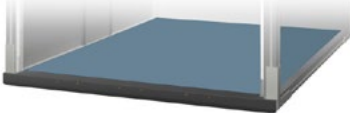
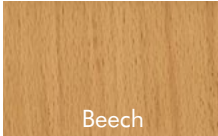
Stannah Midilift platform lifts

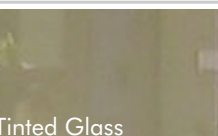
Finishes

	Standard	Options*	
Structure, door frame, carriage and platform	White	Light Grey	Dark Grey
Mid panel	Dark Grey	Stainless Steel	Light Grey
Floor	 Grey Safety Floor	 Vinyl stud Light Grey	 Vinyl stud Dark Grey
	 Aluminium chequer plate floor <i>(standard on external model)</i>	 Slate effect PVC	 Oak effect laminate
		 Flooring by others	
Doors	White	Light Grey	Dark Grey
Fire doors (optional*)	 Beech	 White Oak	 Red Oak  Ash
Infills	White	 Glass	 Tinted Glass

Bespoke Options

Our bespoke solutions offer you a wide range of RAL colours on all of the above components. Choose from a wide range of alternative finishes to ensure your lift meets your specifications. Colours, glass, flooring and more can be selected from a wide range of materials.



Structure, door frame, carriage and platform

Console

Mid panel

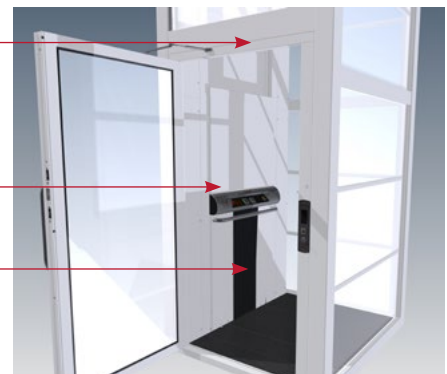

Samples can be provided on request – please call 01264 339090.

The colours and designs reproduced in this document have been matched as closely as printing will allow. It is recommended you obtain samples prior to specification. We are continually developing and improving our range of products and finishes and we therefore reserve the right to alter or amend the specification without prior notice.

*Please note: costs may vary and are dependent on the choice of finishes selected.

Key to colours:

White – BS22B15

Light Grey – RAL 7035

Dark Grey – RAL 7016

Stannah knows how to help people get on with their lives. Whether it is a passenger lift at the station, a dumbwaiter at the coffee shop, an escalator in the shopping centre, or a stairlift at home – we are there quietly helping life happen.

With over 150 years of experience and expertise in the lift industry, we offer customers right across the UK a complete range of lifting solutions to move people and goods efficiently, reliably and safely. We are proud of our reputation for outstanding customer service, delivered from our network of branches.

Whatever your lifting requirements, Stannah can provide a solution.



Stannah Lifts

Anton Mill, Andover, Hampshire SP10 2NX

Telephone: 01264 339090

27109_Midlift 05/21

Meet the family



Stairlifts



Homelifts



Platform lifts



Passenger lifts



Service and goods lifts



Bespoke lifts



Escalators and moving walkways



Lift refurbishments, service and repair